

TALLINN UNIVERSITY OF TECHNOLOGY

School of Information Technologies

Essam Abdelsalam Mahmoud Osman 156422

**DEVICE DISCOVERY METHODS IN D2D
COMMUNICATIONS FOR 5G
COMMUNICATIONS SYSTEMS**

Master's Thesis

Supervisor: Muhammad Mahtab Alam
PhD

Co-supervisor: Luca Reggiani
Politecnico Di Milano
PhD

Tallinn 2018

TALLINNA TEHNIKAÜLIKOOL

Infotehnoloogia teaduskond

Essam Abdelsalam Mahmoud Osman 156422

**D2D SIDES OSALEVATE SEADMETE
AVASTUSMEETODID 5G
KOMMUNIKATSIOONISÜSTEEMIDES**

Magistritöö

Juhendaja: Muhammad Mahtab Alam
doktorikraad

Kaasjuhendaja: Luca Reggiani
Politecnico Di Milano
doktorikraad

Tallinn 2018

Author's declaration of originality

I hereby certify that I am the sole author of this thesis. All the used materials, references to the literature and the work of others have been referred to. This thesis has not been presented for examination anywhere else.

Author: Essam Abdelsalam Mahmoud Osman

20.12.2017

Abstract

Mobile technology is the gate towards the future of connecting people and transferring massive volume of data in high speed, nowadays we are using long term evolution technology (LTE –A) which is the bridge between 4G and 5G, going towards high data rate the early stage of 5G networks was introduced on beamforming technology (BF) and small cell base stations. We expect to have more than 50 billion connected devices to utilize the cellular network services by the end of 2020 [1]. The goals of 5G technology are 1,000x increase in capability, support for 100+ billion connections, up to 10 Gbit/s speeds and below 1ms latency which is not fulfilled in LTE-A. Also, centralized base station (eNB) that control everything in mobile network as in LTE-A become more problem than a solution, as mobile users increase and traffic overhead on base station results in increasing of the mobile outage, low spectral efficiency, and low data rate. An important technology that can help to solve problems in LTE-A and fulfil the requirements of 5G is device to device communications (D2D) which starts in 4G for public emergency services. By using D2D as the main technology in 5G architecture the main question is; how D2D will improve our network by having a solution for high traffic volume, high throughput and low latency in different scenarios of interference management and helps to improve the spectrum efficiency resources to be much better than LTE-A. My research is mainly focused on device to device communications (D2D) on 5G in a decentralized emergency scenario where decentralized means there is no communication or control from base station (gNodeB). So I started with the fundamentals of D2D communications then I went into deep details about peer discovery and selection of D2D pairs using different discovery algorithms after that, I investigated types of interference that face D2D due to resource reuse, then I started to be more familiar with device discovery algorithms after that I choose different algorithms to apply in emergency scenario for single cell and multicell scenario and getting results using MATLAB. My main target is to find suitable solution for discovery and selecting D2D pairs in disaster scenario using different algorithms by comparing results of the average number of pairs that can be selected using different algorithms with respect to the number of devices and probability of the outage from the simulations. The thesis is in English and contains 85 pages of text, 6 chapters, 34 figures, 3 tables.

Annotatsioon

D2D SIDES OSALEVATE SEADMETE AVASTUSMEETODID 5G KOMMUNIKATSIOONISÜSTEEMIDES

Mobiiltehnoloogia on sissepääs tulevikusse kus inimeste kontakteerumine ja massiivsete andmete edastamine toimub väga kiiresti. Tänapäeval kasutame pikaajalist evolutsioontehnoloogiat (LTE-A), mis on 4G ja 5G kiire andmebaaside edastamise ühinev sild. Liikudes suure andmeedastuskiiruse suunas, 5G võrkude varajases staadiumis võeti kasutusele kiire formeerimiste tehnoloogiat ehk beamforming (BF) ja small cell base stations (BS). Me loodame et 2020. aasta lõpuks meil on rohkem kui 50 miljardit ühendatud seadet mis kasutavad mobiilsidevõrgu. 5G tehnoloogia eesmärgid on 1000x võimsuse suurenemine, toetus 100+ miljard ühendusele ja 10Gbit/s kiirus peiteajaga vähem kui 1 ms mis ei ole võimalik LTE-A. Tsentraliseeritud tugijaam (eNB) mis kontrollib kõik mobiiltelefonivõrgus, sama ka LTE-A, praegu muutub probleemideks mitte lahenduseks, kuna kasutajate arv suureneb ja samal ajal suureneb ka liikluse üldkulud ja see põhjustab mobiili katkemise, madala spektraalse efektiivsuse ja ka madala andme edastamist. Oluline innovatsioon mis saab lahendada probleeme LTE-A ja ka samal ajal vastab 5G nõutele, on seadme sideseade (D2D), mis algab 4G-st hädaabiteenuste jaoks. Põhiküsimus, D2D kasutamiseks 5G arhitektuuris on kuidas D2D saab parandada meie võrku, pakkudes lahendust suure liiklusmahu, suure jõudluse ja madala latentsusega erinevate häirete juhtimise stsenaariumide puhul ning aitab parandada spektri tõhususe ressursse, mis on palju parem kui LTE-A. Minu uurimistööl on keskendatud seadmete kommunikatsiooni peal (D2D) 5G korral detsentraliseeritud hädaolukorras. Meie põhiprobleem on seadmete kommunokatsioon. See pärast ma alustasin D2D side alustega, uurisin D2D-paaride vastastikuse avastamist ja valikut, kasutades erinevaid avastamisalgoritme. Samuti uurisin erinevad häired D2D-s, mis põhjustavad ressursside korduvkasutamist. Tutvumine erinevate ressursside jaotamise algoritmidega aitas mind algoritmide valimisega, mida saaksin kasutada ühe- ja mitmekordse stsenaariumi läbiviimiseks ning käivitada MATLAB. Kasutan selleks erinevaid algoritme ühe ja mitme rakude jaoks ning võrdlen paaride keskmiste numbrite tulemused, mis omakorda eraldatakse erinevate algoritmidega arvestades seadmete hulka ja simulatsiooni katkestamise tõenäosust. Lõputöö on kirjutatud Inglise keeles ning sisaldab teksti 85 leheküljel, 6 peatükki, 34 joonist, 3 tabelit.

List of abbreviations and terms

LTE-A	Long Term Evolution-Advanced
BF	Beam Forming
eNB	Base Station in LTE-A
D2D	Device to Device Communications
eNodeB	Base Station in LTE-A
gNodeB	Base station in 5G
GPS	Global Positioning System
MTV	Mobile TV
VC	Video Conference
MS	Mobile Subscribers
VOD	Video on Demand
MIMO	Multiple Inputs Multiple Outputs
BB	Base Band
OFDM	Orthogonal Frequency Division Multiplexer
M2M	Machine to Machine
MBS	Mobile base Station
QOS	Quality of Service
CRN	Cognitive Radio Networks
BS	Base Station
SBS	Small Base Station

mMIMO	Massive multiple inputs multiple outputs
B.W	Bandwidth
UE	User Equipment
RF	Radio Frequency
CSI	Channel State Information
MANET	Mobile Ad-hoc Network
ProSe	Proximity Service
BTS	Base Transceiver station
DUE	Device to Device User Equipment
CUE	Cellular User Equipment
SINR	Signal to Interference Plus Noise Ratio
IP	Internet Protocol
MME	Mobile Management Entity
P-GW	Packet Network Gateway
Rx	Receiver
Tx	Transmitter
SNDR	Signal to Noise plus Distortion Ratio
SNR	Signal to Noise Ratio
PUCCH	Physical Uplink Control Channel
PUSCH	Physical Uplink Shared Channel
UCI	Uplink Control Information
DCI	Downlink Control Information
SR	Scheduling Request
CQI	Channel Quality Indicator
RB	Resource Block
PRB	Physical Resource Block
HARQ	Hybrid Automatic Repeat Request
NACK	Negative Acknowledgement

MCS	Modulation and Code Scheme
DFT	Discrete Fourier Transform
KPI	Key Performance Indicator
PSBCH	Physical Sidelink Broadcast Channel
PSCCH	Physical Sidelink Control Channel
PSDCH	Physical Sidelink Discovery Channel
PSSCH	Physical Sidelink Shared Channel
RRA	Random Resource Allocation
BRA	Balanced Random Allocation
CPA	Cellular Protection Allocation
MSLA	Maximum SINR with Limit on distance of discovery=500m Algorithm
MSNA	Maximum SINR with no limit on distance of discovery Algorithm
SDA	Shortest Distance Algorithm

Table of contents

1 Introduction	14
1.1 Introduction	14
1.2 Applications in 5G.....	16
1.3 Requirements of 5G.....	18
1.4 Device to Device communications background	19
1.5 WIFI Direct,Bluetooth VS LTE Direct	23
1.6 Problem statement	25
1.7 Research questions	25
1.8 Outline	26
2 State of the Art	28
2.1 Device to Device Communications	28
2.2 Peer discovery.....	29
2.3 Resource allocation.....	35
2.4 Power control and security	36
2.5 D2D synchronization and Autonomous mode.....	36
2.6 Literature review.....	37
3 System Model	40
3.1 Small area and large area scenarios	40
3.2 Channel model.....	41
3.3 SINR Calculations	43
3.4 Large scale Area (Multicell).....	47
4 Algorithms for selection of D2D pairs	49
4.1 Different techniques of selecting D2D pair	49

5 Installation setup and simulation results	54
5.1 Installation and main parameter	54
5.2 Simulation results	55
6 Conclusions and future work	65
6.1 Conclusions	65
5.1 Future work.....	66
References	68
Appendix – D2D in 5G paper	73

List of figures

Chapter 1	14
Figure 1. General 5G network arcitecture	15
Figure 2. Requirement and proposed solutions for 5G.....	18
Figure 3. D2D call scenarios	19
Figure 4. WIFI Direct discovery VS LTE Direct D2D discovery.....	20
Chapter 2	24
Figure 5. D2D architecture	25
Figure 6. CQI carried channel	26
Figure 7. CQI report	27
Figure 8. Resource allocation Techniques.....	29
Figure 9. BRA	29
Figure 10. CPA	30
Figure 11. Interference management schemes	30
Figure 12. D2D synchronization	31
Figure 13. Autonomous mode	32
Chapter 3	33
Figure 14. D2D in emergency scenario	40
Figure 15. Single cell representation in MATLAB	41
Figure 16. Channel quality	43
Figure 17. SINR Calculations in Single cell	44
Figure 18. Single cell scenario	46
Figure 19. SINR values between DUE using MATLAB	47
Figure 20. Multicell scenario using MATLAB	48

Chapter 4	49
Figure 21. SDA Flowchart	50
Figure 22. MSNA Flowchart	51
Figure 23. MSLA Flowchart	53
Chapter 5	54
Figure 24. Distances between DUE using MATLAB	55
Figure 25. Multicell VS Single cell	56
Figure 26. Average SINR using different algorithms VS Number of devices	57
Figure 27. SINR measurements for five devices using MATLAB	58
Figure 28. Distances between devices in MATLAB	59
Figure 29. Probability of outages VS Number of devices	60
Figure 30. Average number of pairs VS Discovery distances variations	61
Figure 31. Outage percentages VS Discovery distances variations	62
Figure 32. Distances of discovery VS Number of devices	63
Figure 33. Effect of SINR threshold on Number of D2D pairs.....	64
Figure 34. Effect of SINR threshold on outages percentages	64

List of tables

Chapter 1	14
Table 1. Comparison between MANETs and D2D	19
Table 2. Comparison Between D2D and other wireless technologies	24
Chapter 5	54
Table 3. System main parameter	54

Chapter 1 introduction

1.1 Introduction

Every new generation in wireless communications tried to develop faster speed and more functions for our smartphones. 1G was the first cell phone, 2G was the first text messages cell phone, 3G was the beginning of real browsing online, 3G has supported real-time application services to the mobile phone users with high-speed data. A number of the applications like video on demand (VOD): Video on Demand has provided a scalable service to the 3G subscribers than GSM users. It's provided the services through a satellite network over a large geographical area. Global positioning system (GPS): GPS has provided the precise location and on time data in geographical areas, supported by satellite navigation system. In order that anyone might access the location data through a GPS receiver with 3G broadband access. The GPS program is that the backbone of traffic system and it provides the essential ability to a military network, civil and business users around the world. Mobile TV (MTV): Television was watched through a mobile device and hand-held device with 3G speed. 3G mobile networks provided a transparent vision of mobile TV services with high-speed broadband access. The global tv stations provided TV services and delivered it, it's extra options like downloading then saving the TV programs from the net. Video conference (VC) was allowed in multiple locations to speak instantly with 3G speed. The video conference was totally different from videophone calls. It's designed for conference purpose too at anywhere [2].

LTE was launched on Dec 2009 by Telia Sonera from Scandinavian countries. LTE stands on orthogonal frequency division multiplexer (OFDM), Multiple inputs multiple outputs (MIMO) techniques with continuous development by 3GPP. This mobile telecommunication system reached worldwide and it provides broadband wireless service through LTE and WIMAX telecommunication technologies. The mobile subscribers (MS) prefer to connect the Smartphone to the internet through Base stations (BS) at short time. The BS also controls the channel access of mobile users. LTE-A has managed that Picocells, femtocells multi-carrier channels to be up to one hundred MHZ wide. LTE has

been managed with GSM/UMTS and CDMA operators. 4G provide a lot of integrity through OFDM with Wi-Max, it can be delivered up to seventy Mbps over a wireless technology, and the indoor user reaches up to 1Gbps. 4G encompasses a facility to transfers information like audio, video, and photos during a voice call. But as more users came online LTE has reached the limit that is capable of data rate [3].

Now we are towards the 5G which will be able to handle thousands of times of traffic more than today’s network and will be ten times faster than LTE. The increasing number of users, huge amount of data and the need for high data rate push us towards the 5G network. 5G networks are characterized by unique features like ubiquitous connections, low latency, and high-speed data transfer, Ubiquitous connectivity requires user equipment (UE) to support a variety of radios and bands due to the global different operating bands. The 5G networks will support real-time applications, and services with zero delay tolerance, and of course to achieve zero latency we need very high-speed data rate which will be of the order of Gigabits per second to users and machines.

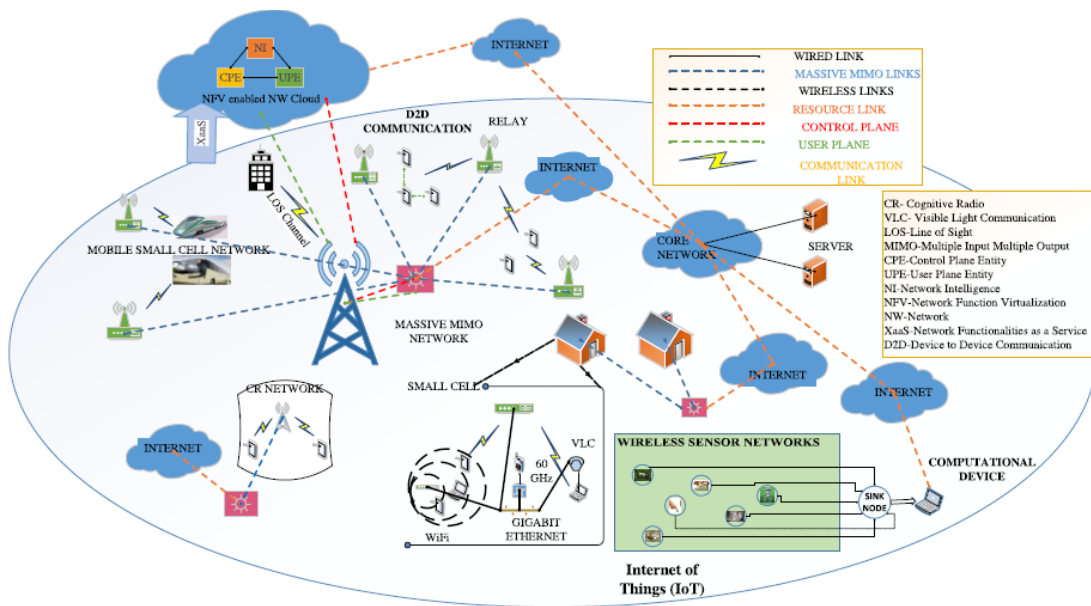

Figure 1. General 5G Network Architecture [4]

5G cellular networks are based on three categories. (i) Centralized user has providing 24x7 device connection with uninterrupted services. (ii) A centralized service provider which deliver intelligent transport system and sensors connectivity. (iii) Centralized network operator is providing scalable, efficient power and secure infrastructure communication. Wireless networks will include technologies and applications like

machine to machine (M2M) in applications with quality of service (QoS) guaranteed. Two-tier network architecture has given in starting of research work, wherever the mobile Base station (MBS) stays on higher tier there is small base station (SBS) below the management of MBS within the bottom tier. little cells and macro cell share the waveband. macro cell controls all the little cells like femtocell, Pico cell, and microcell. Small cells improve the coverage and services of network architecture. Cognitive radio networks is the enabling technology for supporting dynamic spectrum access where spectrum is allocated dynamically in cognitive radio networks nodes (CRN-based) and D2D communication improves two-tier network to multi-tier network. There are also five new technologies that are the fundamental of 5G: Millimeter Waves, Small Cells, Massive MIMO, Beam forming and direct D2D Communications [4].

1.2 Applications in 5G

1.2.1 Public Safety Network

From previous experiences from the world's recent catastrophes such as the hurricane Katrina of USA in 2005 and the earthquake of Haiti in 2010 revealed that the infrastructure of mobile networks was severely destroyed, which made the rescue of survivals more difficult. D2D communications in 5G have proposed as an attractive solution for communication without relying on mobile networks. Devices that are located in close distances can establish their own network and maintain temporary transmit/receive links privately. Moreover, D2D communications enable high data rate by using the outband spectrum (e.g., the 2.4 GHz free band), and the unlicensed frequencies that are used by cellular users [5]

1.2.2 Millimetres Waves

A new technology for the future of 5G networks is Millimetres Waves communications which gives the UE multi-Gigabits per second, it works on wide frequency Band from 30 GHz to 300 GHz, studies suggest that using millimetres wave communications will increase frequencies from the currently saturated 700 MHz to 2.6 GHz radio spectrum bands for wireless communications. Millimetres Waves spectrum would enable service providers to expand the channel bandwidths (B.W) so much beyond the current 20 MHz channels utilized by 4G customers and this can result in a good increase to data capacity

and low latency for traffic [4]. Recently the mix of cost-efficient CMOS technology and high-gain antennas at the mobile and base station, strengthens the value of mm-wave wireless communications. By increasing the radio frequency (RF) channel B.W for mobile radio channels, the data traffic capacity is increased significantly, whereas the latency become very low for digital traffic, therefore supporting far better internet-based access and applications that need very low latency. Smaller wavelength of Mm-wave frequencies, will open new spatial processing techniques like mMIMO and adaptive beamforming [4].

1.2.3 Small Cells

Small cells are short range mobile phone base stations which may be a great solution for 5G high capacity, small cells operate at very low radio power levels, this feature increase battery life of user equipment (UE). Small cells are a cost-effective solution to remove the gap between data demand and capacity. Small cells have many advantages for enhancing coverage and capacity, example if there is high buildings or mountains which can create a large blind spot area which can be covered by outdoor small cell or can be used to extend coverage at the edges of the cell also can be used in emergency situation as portable small cells [6].

1.2.4 Massive MIMO

mMIMO systems is a very large-Scale antenna system which use antenna arrays with hundreds of antennas at MBS for serving many UEs simultaneously, mMIMO system reduces latency and increase capacity due to spatial multiplexing, the channel maximum capacity of MIMO enlarged quickly with the increase of array antennas that is called Shannon capacity [7]. MIMO for 5G could be a cost-effective integration within the overall network. The cell is divided into small cell, where small cells have high frequency, wider information measure and high Bit Rate [7]. For the digital fixed BF, equal variety of digital baseband signals and baseband chain that increase the price of the mMIMO transceiver remarkably. On the other hand, for the analog fixed BF, the quantity of the Base Band (BB) chains is often restricted for the analog frequency (RF) signals compare to the digital precoded outputs, which ends within the price reduction [7]. The analog fixed BF and also the digital precoding, which is hybrid BF, are often effective to cut back the price of the mMIMO transceiver. The channel state info (CSI) isn't offered within

the adaptive BF that is obtainable within the hybrid BF, therefore it is often assume that the hybrid BF for the transmission appropriate for the super high bit rate transmission.

1.2.5 Beam Forming

Beam forming is a signal processing technique that make BS instead of broadcasting in all directions it will allow base stations to send focus beam of data to specific users this technique prevents interference and it's more efficient as it allows multiple inputs and outputs data stream at the same time [8].

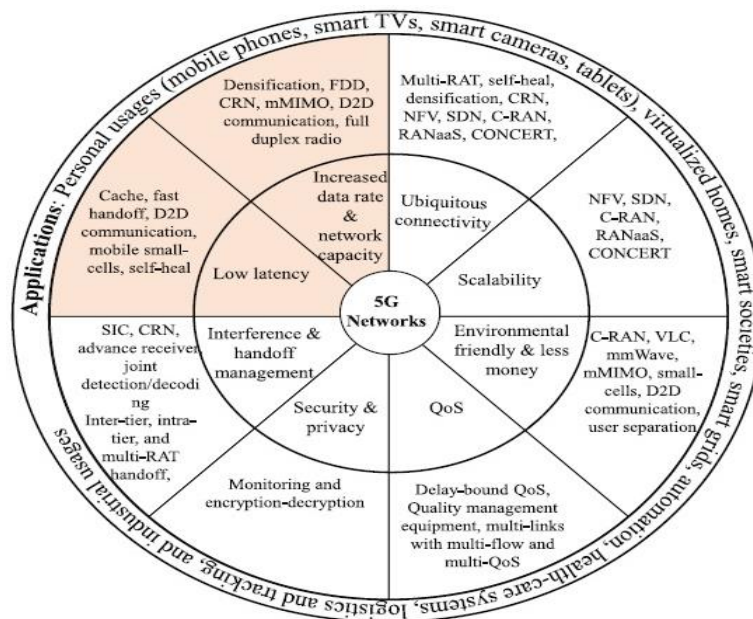

Figure 2. Requirement and proposed solutions for 5G. [2]

1.3 Requirements of 5G

From figure 2 we can see the development of 5G requirements and the proposed solutions (highlighted). One of the main technology solutions for enhancement of 5G network that started in the LTE and will be my main topic is D2D communications. D2D when it first revealed it appears like mobile Ad-hoc Networks (MANETs) and cognitive Radio Network(CRN) as both are collections of mobile nodes that form temporary decentralized network but a lot of drawback that faces MANETs which make it not Quality of service guaranteed. These drawbacks are unreliability of wireless channels, no centralized control [9]. Also in CRN a lot of issues include white space detection, collision avoidance, synchronization and spectrum sensing. If we go towards D2D Networks it can be control by base station, partially controlled or device controlled [9].

MANETs VS D2D Networks

Multi-hop Networks	One-hop networks
No QoS guarantee	QoS guarantee
No improvement in Spectral efficiency	Spectral efficiency
No centralized control	Centralized control, partially control or device control
No handover	Hand over available
Poor resource utilization	Efficient resource utilization

Table 1. Comparison between MaNETs and D2D. [9]

1.4 Device to Device Communications background

As telecom operators are suffering to deal with the current demand of mobile users, new facts in depth applications are rising inside the daily routines of mobile customers (e.g., proximity-service). moreover, 4G cellular technologies (WiMAX [10] and LTE-A [11]), that have extraordinarily efficient physical and MAC layer performance, are nevertheless lagging in the back of cellular customers' booming statistics demand. Therefore, researchers are seeking for brand new paradigms to revolutionize the traditional voice call methods of cell networks. D2D conversation is one of such paradigms that appears to be a promising technology in future mobile generation technologies and will be one of the main applications in 5G networks architecture. D2D communications in cell networks is defined as direct connection among two mobile users without traversing the gNodeB where gNodeB is the name of the base station in 5G [12]. D2D communications works on the licensed mobile spectrum (i.e., inband) or unlicensed spectrum (i.e. Outband). In a conventional mobile network, all communications ought to go through the eNode even supposing both D2D pairs are in coverage. This structure suits the traditional low data services like voice and text message. However, cellular users in nowadays cell networks use high data traffic (e.g., video sharing, gaming,) wherein they could potentially be in variety for direct communications (i.e., D2D). D2D communications in this scenario can increase the spectral efficiency. We have to consider that the advantages of D2D communications aren't only restrained to improved spectral performance, D2D communications can also improve power efficiency, delay, and latency.

Researchers proposed D2D first to allow multihop relays in cellular networks [13]. Later the works in [14]– [15] investigated the potential of D2D communications for improving spectral efficiency of cellular networks. Soon after, other potential D2D applications were added which include multicasting [16], peer-to-peer communication [17], (M2M) communications [18], cellular offloading [19], and so on. The different popular use-cases of D2D communications are shown in Figure 1. The primary attempt to implement D2D communication in a mobile network made by way of Qualcomm’s Flash LINQ [20] which is a PHY/MAC layer structure for D2D communications underlying cell networks. Flash LINQ takes benefit of OFDM/OFDMA technology to start the first attempt of D2D.

1.4.1 D2D Calls Scenarios

We have four main different types of D2D communications [21]:

1) Relay device to other device or devices with control link established:

Relaying with controlled link connection from the operator, devices at the cell edges or in poor coverage areas are capable of communicating with gNodeB by relaying information through different devices. All tasks of building the communication between the devices are handled by gNodeB.

2) Direct D2D communications under gNodeB controlled links from operator:

Two devices communicate directly with each other, with control links provided by gNodeB in this scenario the communication is entirely managed by gNodeB. AS we can see in figure 3- (2). a centralized Base station take the rule of interference management

3) Relay with device controlled link establishment:

Two devices communicate via relays, Resource allocation and interference management all is managed by the devices themselves, no management of base station occur.

4) Uncentralized D2D Communications:

Devices communicate directly, where there is no role from base station. Call setup and management are handled by the devices themselves as shown in figure 3-(4)., this

two-tier network architecture have a lot of benefits over ordinary cellular architecture like:

- a) Single hop communication: the devices will communicate with each other through one hop. Lesser resources are then needed for the communication leading to efficient usage of the spectrum. Since proximity users directly communicate with each other in D2D communication channels, latency is greatly reduced. These are required aspects in 5G cellular network.
- b) Spectrum reuse: same spectrum is shared by the D2D users (DUE) with the cellular users (CUE). This improve the spectrum reuse ratio.
- c) Power optimization: As D2D links exist between near devices, over short distances (Max.500m), transmission power is less. This enhances the battery lifetime of the devices. As a result, higher energy efficiency is achieved with D2D communication in cellular networks
- d) Improvement of coverage area: As we discussed in using relays in point (1) and (3) will help to connect D2D users that have no coverage from gNodeB at cell edges to be connected

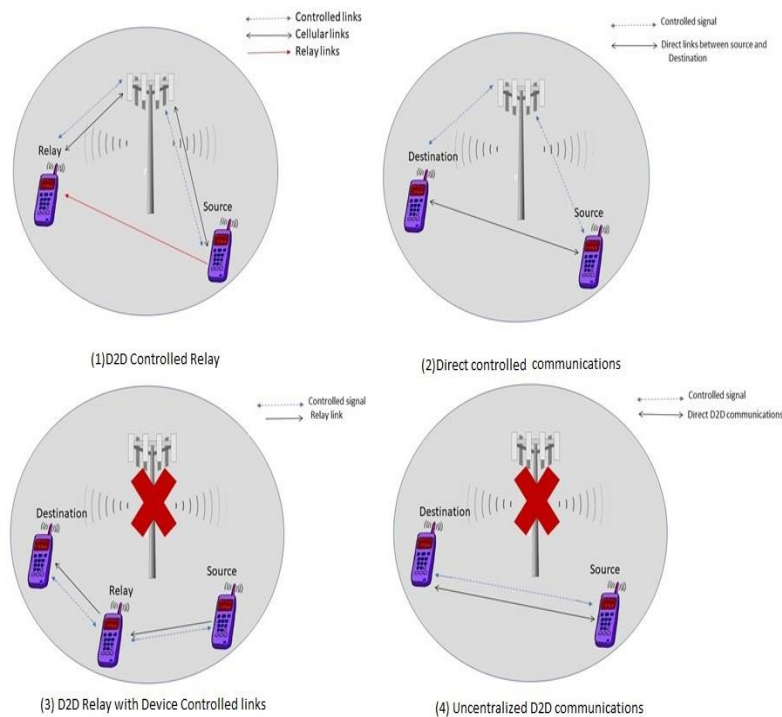

Figure 3. D2D Call Scenarios. [21]

1.5 WIFI Direct, Bluetooth VS LTE direct

WIFI direct is to connect two devices directly via WIFI to transfer IP data and it is also possible to make discovery over WIFI direct, WIFI Direct discovery is a two-step process where the device first broadcast request asking for Mac ID of all of the devices that are closed to it then all devices that hear the request sent to the device a unicast respond, after that the device send a unicast request for each device to discover its services and get a unicast response from each one. This two steps discovery as shown in figure 4. has bad impact on energy efficiency. In Bluetooth discovery is only in unlicensed band similar to WIFI Direct which is subject to interference also it is asynchronous discovery which means that receiving devices don't know when other devices are transmitting, as more devices transmit receiving devices need to stay longer to discover devices which has also bad impact on energy efficiency. In LTE direct this process is far more efficient as expressions broadcasted by D2D users in the Discovery process contains ID, and services of each Device, D2D direct is synchronous discovery where device transmit and receive at the same time also one of the important advantageous of D2D Direct is the discovery range as device to device user equipment (DUE) can discover up to 500 m range while WIFI direct can discover devices up to 200 m maximum while Bluetooth can discover devices up to 300 m. From the main points that is required by the 5G network to cover the problems of LTE is data rate we can see the high difference of data rate of D2D compared to WIFI direct and Bluetooth as in D2D maximum data rate is 5-10 Gbps, while WIFI direct is 250 Mbps and Bluetooth is 48 Mbps only that's why the future of 5G network will depend on D2D Communications [22],[23]

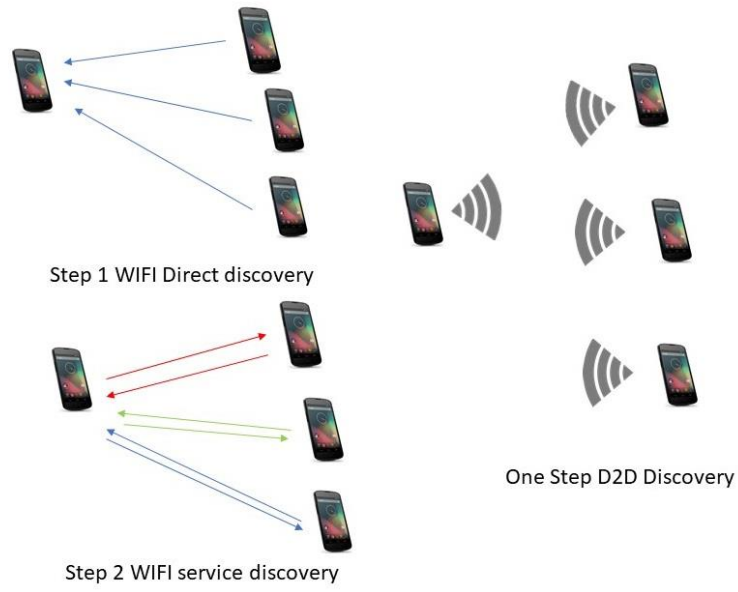

Figure 4. WIFI Direct Discovery Vs LTE direct D2D Discovery. [22]

Feature Name	D2D	Wi-Fi Direct	Bluetooth5.0
Standardization	3GPP Release12	802.11	Bluetooth SIG
Frequency band	Licensed band and unlicensed band	2.4 GHz, 5GHz	2.4-2.485GHz
Max transmission distance	500 m	200m	300m
Quality of service	Qos guarantees	No Qos guarantees	No Qos guarantees
Max data rate	5-10 Gbps	250Mbps	48Mbps
Device discovery	BS coordination	ID broadcast and embed soft access point	Manual pairing
Uniformity of service provision	Yes	No	No
Application	Public safety, Content sharing, Local advertising, Cellular relay	Content sharing, Group gaming, Device connection	Object Exchange, Peripherals Connection

Table 2. Comparison between D2D and other wireless Technologies. [22]

1.6 problem Statement

In D2D communications systems, terminals that is supported with D2D features can communicate to each other even without control from Base station. In this thesis my main scenario is in public safety so gNodeB will be not working, and as we knew that wireless technology has limited bands to use, so reusing the frequency spectrum is one of the main challenges that facing device to device communications in emergency scenario. So, the main problem that my research is trying to figure it out is how to select D2D pairs with minimum interference and best algorithm to guarantee quality of service (Qos) in this disaster scenario. In previous researches if a disaster happens like earth quake, floods, terrorist attack to network architecture or even wars, we have solutions like portable base Transceiver station (BTS) or drones and most researcher using different techniques as in [24] which based on spreading technique or in [25] which also consider partial coverage and not consider the devices is in total out of coverage scenario. In most previous work we didn't consider the device terminal to be the main part to control and to initiate the calls without the need to gNodeB, of course there is a lot of challenges that will face it like device discovery, selecting best pairs to initiate the rescue call, resource allocation and interference management also security as devices transfer and control information between each other and data protection from intruders in case of using relays. The main challenges were to design a real urban cell that the core network is not working on it due to a disaster and devices is randomly distributed in the cell ready for measurement that I will make it to select D2D pairs that can communicate with high Qos using different algorithms in this scenario with resource reuse so all DUE have interference on each other, and to identify the information that is needed to be sent between terminals using D2D channels.

1.7 Research questions

Starting from the hypothesis that adding decentralized D2D feature for 5G Architecture will benefit the mobile communication system,

what are the added benefits of using decentralized D2D Technology in 5G Network?

1) Applications

- Public Safety
- Offloading traffic from gNodeB

2) Performance

- Spectrum efficiency
- High data rate
- Low latency

And as mentioned in figure 2., this a great evolution for mobile network architecture to have Low latency, high data rate and increase network capacity

What are the Challenges of D2D communications?

- Frequency Reuse
- Interference management and Resource allocation
- Security

Which evaluation metric should be used to fairly evaluate the simulation results?

- A system model based on technical aspects in sec 3.2 is executed in MATLAB and the results evaluated.

Which algorithm will be used to get suitable results?

- A comparison between three algorithms (Maximum SINR, Minimum distance, Hybrid) will be done

1.8 Outline

The remaining chapters in this thesis is organized as follows: Chapter 2 gives a general overview on D2D communications and challenges. A short summary on other topics that is related to D2D researches is given and device to device communications is described in details in terms of architecture, access technology, and applications. After the state of the art of D2D communications technology, Chapter 3 describes the way that D2D can

be represented in a single and multicell model and all system calculations. Chapter four starts focus on the algorithms that will be used to solve the main problem of selecting D2D pairs. The performance evaluation by means of simulation results is described in chapter 5. The last part describes the simulation results of the different algorithms and comparing the results. Chapter 6 is the conclusions of the general ideas and results presented in previous chapters. Finally, future work related to this research is discussed.

Chapter 2 State of the Art

Research in the field of D2D communications in 5G is experiencing enormous growth. A IEEE search for papers written about this topic results in thousands of papers. This chapter gives an overview of the D2D technology and a detailed description of the device to device Peer discovery technology that are the basis for this thesis

2.1 Device to Device Communications

D2D communications will take a major role in 5G network as by direct communication we will improve spectrum reuse, throughput, energy consumption, coverage, and reduce end to end latency. 3GPP is investigating D2D communications as proximity services (ProSe). In particular, the feasibility of ProSe and its use-cases in LTE are studied in [26] and the required architectural enhancements to be usable are investigated in [27]. Presently, proximity service is in 3GPP release 12 as a public safety community feature [13]. A short evaluate of standardization activities and the basics of 3GPP ProSe can be find in [23]. The general public of the literatures on D2D communications proposes to use the cell spectrum for each D2D and mobile communications (i.e., underlay inband D2D) [28]. Those works commonly take a look at the problems of interference mitigation among D2D and mobile communications [29]. In an effort to avoid the interference issues a few researchers recommend to commit part of the cellular resources to D2D communications (i.e., overlay inband D2D). Others prefer to choose outband for D2D communications in mobile networks rather than inband in order that the valuable cellular spectrum be no longer affected by D2D communications, In our research resource reuse gains are my utmost concerns so that available mobile resources not to be wasted [29]. In outband communications, the coordination between radio interfaces is both controlled via the BS (i.e., managed) or the users themselves (i.e., independent) [31] as the main focus in my research. Outband D2D communication faces some challenges in coordinating communications over dedicated bands because typically D2D connections happens on a

2nd radio interface (e.g., WIFI Direct and Bluetooth [22]). The studies on outband D2D inspect troubles consisting of energy efficiency and different architectural design [26].

2.2 Peer discovery

The process of peer discovery should be efficient, so that D2D links are discovered and established quickly. D2D communication may be a comparatively new technology in cellular networks. Therefore, widely acceptable solutions for peer discovery are still missing, Researchers are searching for new and different techniques for peer discovery. From the perspective of the network, device discovery can be controlled by the base-station either tightly or lightly. Peer discovery in cellular networks is divided into with or without UEs transmit “discovery beacons” [24],[31]. Beacons are 128-bit service layer identifier used in D2D discovery, they are expressions which can represent identity, services, interest or location. A device can be broadcasting through the air an expression like we are a coffee shop, a device with application filters out relevant expressions from all it detects through air interface so we can get expressions for emergency or other interesting things. So, we can send our positions to other mobile and we can calculate SINR based on any algorithm.

2.2.1 D2D discovery in centralized network

In this scenario D2D depends on core network so beacons are used for D2D discovery but if no beacon is transmitted, discovery should be completed with the help of eNodeB or the core network. In [32], eNodeB determines if D2D pair belong to its cell by checking the IP addresses of the packets or comparison a token possessed by the D2D pair. In [27], UEs may send service or interest lists to mobile management entity (MME) and acquire notification from other UEs with same interest. In [27], the packet network gateway (P-GW) determines if D2D pair belong to same cell by detection a routing-back IP packet. However, to implement the solutions, new functions should be added to P-GW. When the UE is in coverage, transmission mode 1 (network-directed) is used where the eNodeB can dynamically assign resources to the UE for D2D transmission. In this transmission mode, the eNodeB can guarantee no collision between any side link transmission and any uplink transmission, or between side link transmissions

In the below figure 5. shows air interface between D2D Network architecture:

PC1: Interface between ProSe application within the UE and ProSe Application Server.

PC2: The interface between ProSe Application Server and ProSe function.

PC3: The interface between the UE and ProSe function.

PC4: The interface between the EPC and also the ProSe function.

PC5: it's a one-to-many communication interface between two D2D UEs

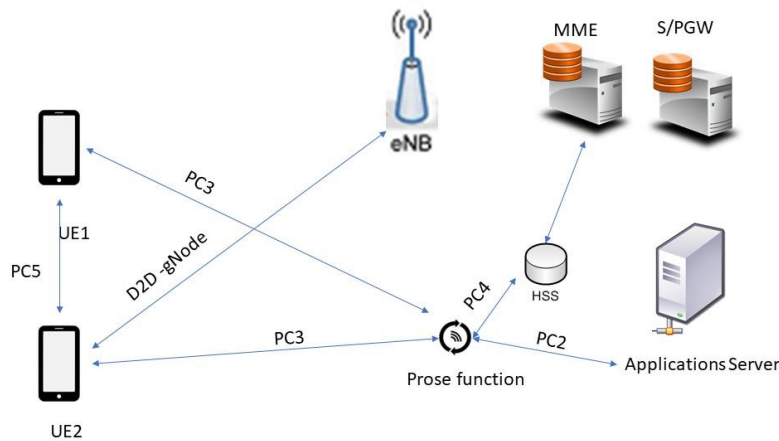

Figure 5. D2D Architecture [33],[34]

2.2.2 Channel Quality Indicator

One of the most important feedback about the channel status that is sent to the network is CQI which stands for Channel Quality Indicator. the CQI values are from 0 ~ 15. 15 indicates the first-rate channel quality and 0,1 shows the poorest channel. according to the value UE reports, network transmit statistics with distinctive transport block size. If network receives excessive CQI value from UE, it transmits the statistics with larger delivery block size and vice versa.

How UE can calculate CQI?

- signal-to-noise ratio (SNR)
- signal-to-interference plus noise ratio (SINR)
- signal-to-noise plus distortion ratio (SNDR)

$$\text{SNDR} = \frac{P_{\text{Signal}} + P_{\text{Noise}} + P_{\text{Distortion}}}{P_{\text{Distortion}} + P_{\text{Noise}}}$$

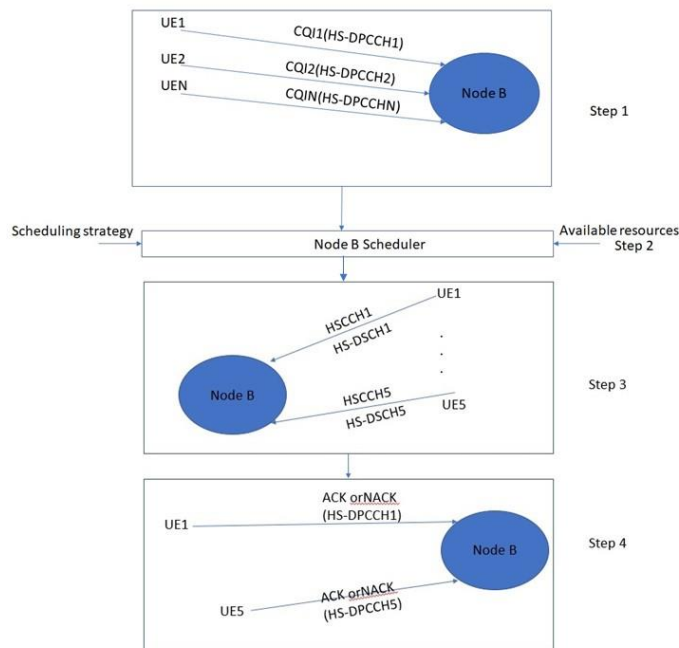

Figure 6. CQI Carried Channels [35]

2.2.3 code rate

It is the ratio of the data rate of a sub frame and the maximum data rate that ideally can be allocated inside the sub frame., this means that the code rate is described as the ratio between the transport block size and the number of physical layer bits in sub frame which can be available for transmission of that transport block". A low code rate means that more redundancy bits are inserted throughout the channel coding system and a higher code rate means that less redundancy bits are inserted [33].

CQI index	modulation	code rate x 1024	efficiency	CQI index	modulation	code rate x 1024	efficiency
0	out of range			0	out of range		
1	QPSK	78	0.1523	1	QPSK	78	0.1523
2	QPSK	120	0.2344	2	QPSK	193	0.3770
3	QPSK	193	0.3770	3	QPSK	449	0.8770
4	QPSK	308	0.6016	4	16QAM	378	1.4766
5	QPSK	449	0.8770	5	16QAM	490	1.9141
6	QPSK	602	1.1758	6	16QAM	616	2.4063
7	16QAM	378	1.4766	7	64QAM	466	2.7305
8	16QAM	490	1.9141	8	64QAM	567	3.3223
9	16QAM	616	2.4063	9	64QAM	666	3.9023
10	64QAM	466	2.7305	10	64QAM	772	4.5234
11	64QAM	567	3.3223	11	64QAM	873	5.1152
12	64QAM	666	3.9023	12	256QAM	711	5.5547
13	64QAM	772	4.5234	13	256QAM	797	6.2266
14	64QAM	873	5.1152	14	256QAM	885	6.9141
15	64QAM	948	5.5547	15	256QAM	948	7.4063

Figure 7. CQI report [33]

PUCCH (Physical Uplink Control Channel) carries a set of information called "UCI (Uplink Control Information)". (This is similar to PDCCH which carries DCI (Downlink control information)". [35]

PUSCH (physical uplink shared channel) Its main function is to carry RRC (Radio resource control) communications messages, UCI (uplink Control Information) and application data. Uplink RRC messages are carried using PUSCH. The PUSCH carries both user data as well as control signal information. [33]

UCI stands for Uplink Control Information. It is carried by PUCCH or PUSCH. UCI is the opposite channel of DCI, but the information/role of UCI is very small comparing to DCI.

The information carried by UCI is:

- SR (Scheduling Request)
- HARQ ACK/NACK
- CQI

SR is a Physical Layer message for UE to ask Network to send UL Grant (DCI Format 0) in order that UE will transmit PUSCH. [35]

2.2.4 Downlink Frame Structure

In LTE, each downlink frame is of 10 ms length, and consists of 10 sub frames. Every sub frame of length 1 ms, which is known as transmission time interval (TTI), consists of two 0.5 ms slots. Each slot, in turn, consists of seven OFDM symbols. In the frequency domain: the system B.W is split into several subcarriers, each of bandwidth of 15 kHz. If $B = 10$ MHz, 600 subcarriers that is obtained using a 1024-point DFT are used for data and information management. A set of 12 consecutive subcarriers for a length of one slot is known as Physical Resource Block (PRB) [33]

Feedback: The feedback info sent by the (UE) is known as the Channel Quality Indicator (CQI). The 4-bit CQI value indicates an estimate of the modulation and coding scheme (MCS) that the UE can receive dependably. It is based on the measured received signal quality on the downlink. The BS controls how often and when the UE feeds back CQI. There are two types of feedback: Aperiodic feedback and Periodic feedback. In aperiodic feedback, the UE sends CQI only when it is asked to by the eNode. On the other hand, in periodic feedback, the UE sends CQI periodically to the eNode; the time between 2 consecutive CQI reports is communicated by the eNode to the UE at the beginning of the CQI reporting process. In each type of these feedback, the best possible frequency resolution for CQI reporting is a sub-band, which consists of Q contiguous PRBs. According to the system bandwidth and the type of feedback, q ranges from two to eight.

The UE will report CQI at different frequency in aperiodic CQI feedback. Specifically, in broadband feedback, the UE reports one broadband CQI value for the whole system B.W. In Sub-band-level feedback, the UE reports CQI for each sub-band. In UE selected sub-band feedback, the UE reports the position of M preferred sub-bands that have the highest sub-band CQIs and a single CQI value for these sub-bands. In periodic CQI feedback, only wideband and UE selected sub-band feedback are possible. Even in the latter, the CSI feedback is very limited; the sub-bands are further clustered into bandwidth parts, and the UE reports the CQI of only one sub-band from each bandwidth part

2.2.5 D2D peer discovery in uncentralized scenario

If UEs transmit beacons to advertise their presence, peer discovery might be completed by themselves. Several existing wireless technologies, depend on peer discovery with beacons e.g., Bluetooth and Wi-Fi Direct [21]. This D2D discovery without the gNodeB support is the best solution for public safety networks. In this scenario transmission mode 2 (UE-selected) is used where the UE selects which resources to use for transmission. Transmission mode 2 is applicable to all scenarios, in coverage and out of coverage. The resources are selected at random to minimize the collision risk [33].

2.2.5.1 D2D physical channels

Side link is a kind of communication links between device and device without going through gNB. It means that it requires new physical layer design. But to minimize the design changes of existing implementation, the new physical layer is designed not to differ too much. We will use very similar waveform in D2D communications based on SC-FDMA in both directions.

Physical Side Link Broadcast Channel (PSBCH), which carries system information and synchronization signals;

Physical Side Link Control Channel (PSCCH), which carries UE-to-UE control plane data

Physical Side link Discovery Channel (PSDCH), which supports UE direct discovery transmissions

Physical Side Link Shared Channel (PSSCH), used for user plane data transmissions.

2.3 Resource allocation

After Peer discovery, we need available resources for enabling communication over the direct links, Resource allocation has three techniques:

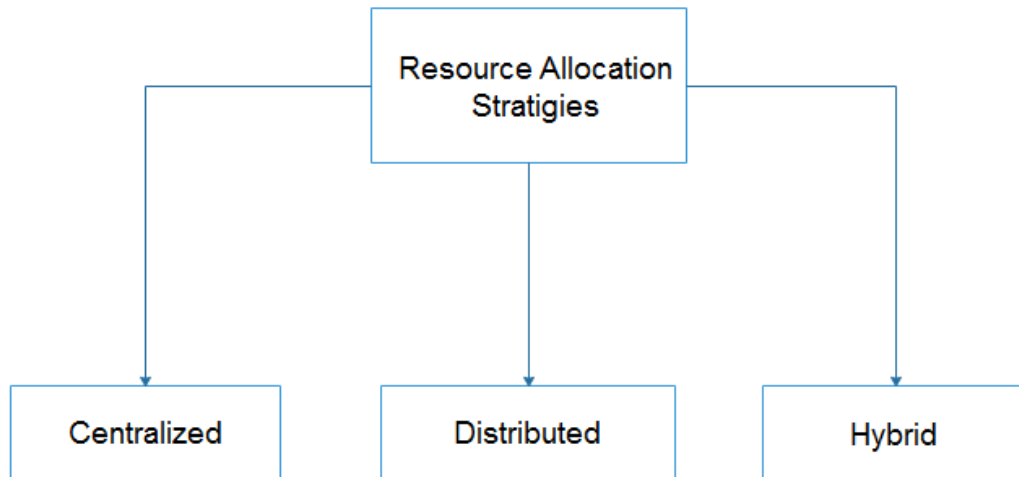

Figure 8. Resource allocation Techniques [36],[37]

- **Centralized:** which is used in case of small networks as it causes network complexity in large networks
- **Distributed:** Which is used in large networks as it tends to decrease network scalability.
- **Hybrid:** is a research open solution [36],[37]

2.3.1 Random Resource Allocation (RRA)

This algorithm randomly selects from the available resources to be reused by D2D pairs without any constraints, this is the simplest one to apply but of course it is not practically used in real network as we will have high interference by the way of resources selection randomly [38].

2.3.2 Balanced Random Allocation (BRA):

BRA is an improvement for RRA, we select resources by the minimum number of times a resource has been used.

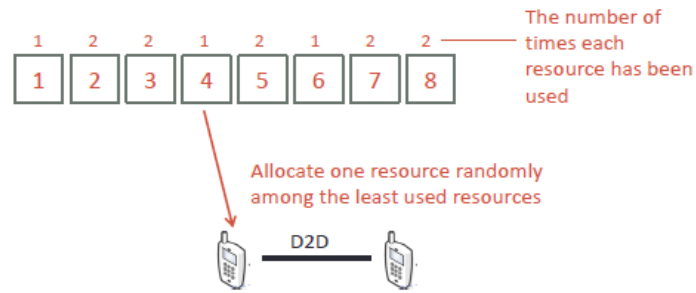

Figure 9. BRA [38]

2.3.3 Cellular Protection Allocation (CPA)

This algorithm used two constraints for resource allocation minimum number of times a resource used and maximum cellular path gain.

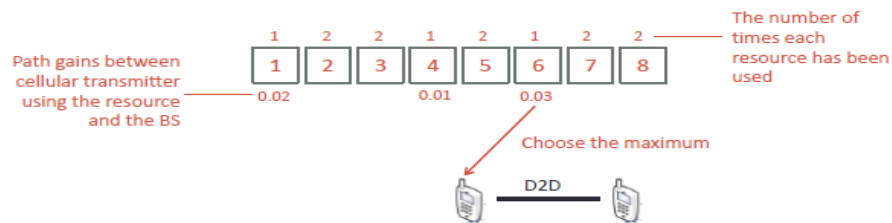

Figure 10. CPA [38]

2.4 Power control and Security

Adjusting transmission power for reusing the frequency is an area of interest for the researchers. It is particularly important in case of uplink transmissions because of the near-far effect and co-channel interference. Security needs to be well considered during implementation of the D2D Communications in cellular network as channels are vulnerable to a number of security attacks like eavesdropping, message modification, and node impersonation [39].

2.5 Interference management schemes

We divide the schemes by interference avoidance, interference cancellation and interference coordination Techniques

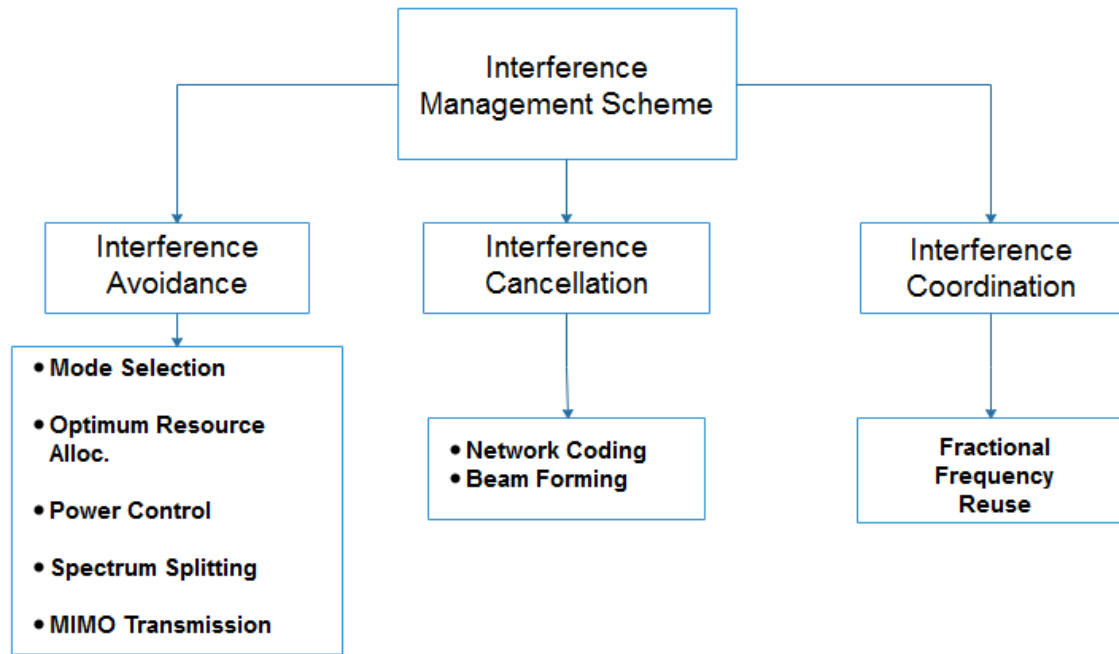

Figure 11. Interference management Schemes [9]

2.6 Literature Review

In my project “Device Discovery methods in D2D communications for 5G communications systems”, my focus will be only on uncentralized scenario for selection of D2D pairs in discovery phase in emergency scenario, I will build my initial scenario for this purpose. Also, I need to build my scenario on call setup in decentralized case without the usage of gNodeB so our call scenario in emergency situation will be based on decentralized D2D in LTE-A

2.6.1 D2D synchronization and Autonomous mode

– Synchronization and radio parameter acquisition

In order to demodulate the data, transmitter (Tx) and receiver (Rx) have to be synchronized in time and frequency and to know who will be responsible of synchronization this depend if Tx is in-coverage or out-coverage

- a) In coverage: synchronization is provided by gNodeB
- b) Out coverage: synchronization is provided by UEs.

Figure 12. shows the selection of synchronization source in coverage and out coverage

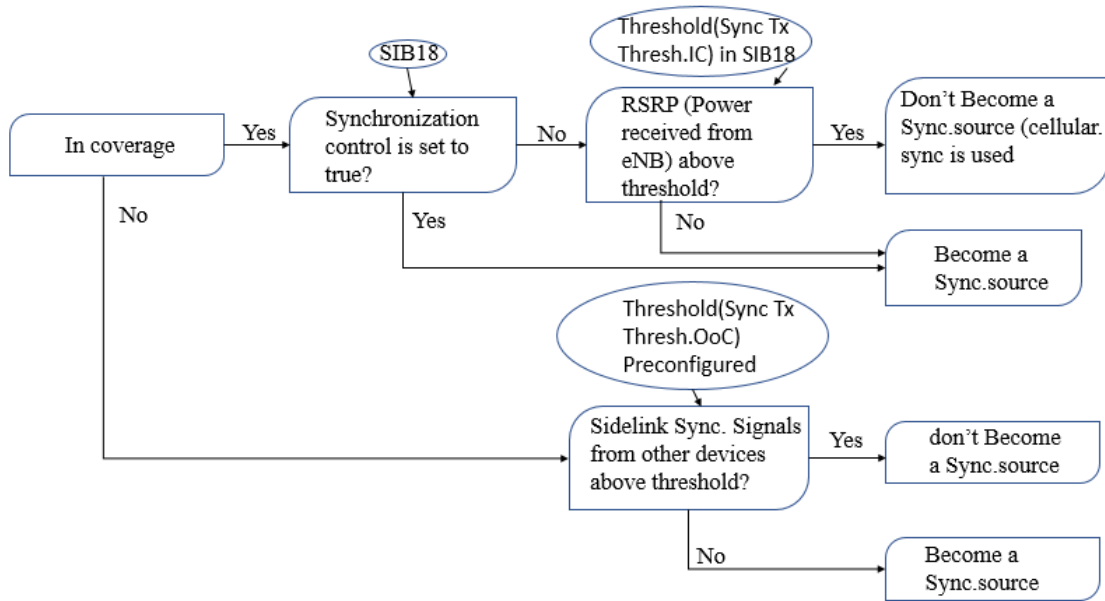

Figure 12. D2D Synchronization [40]

Autonomous mode: A DUE on its own selects resources from resource pools allocated on a non-UE specific basis. Protection from network failure which is used in public safety [40]

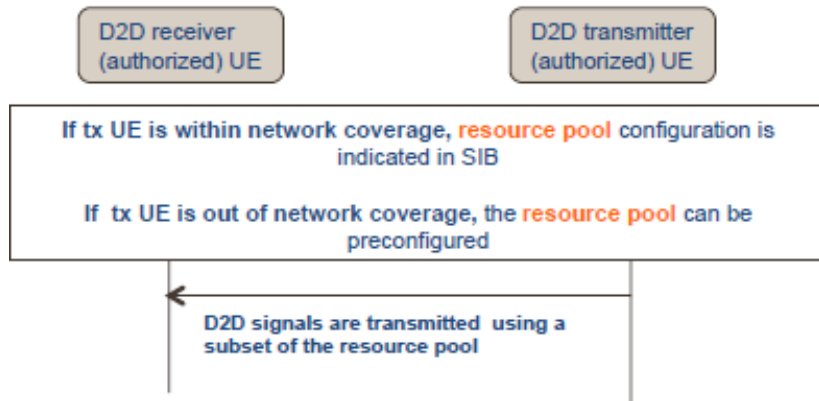

Figure 13. D2D autonomous mode [40]

2.6.2 Methods of Discovery in uncentralized case strategy

- a) As I explained in section 2.1 and 2.4, we will send beacons for device discovery broadcasted using side link channel PSDCH using preconfigured discovery resource pools [38]
- b) Filtration of this beacons by receiver (Rx) and acknowledge response with all main information: temporary ID, location, SINR will be sent.
- c) Resource pools configurations for D2D transmission and reception will be sent on PSCCH and PSSCH up to eight resource pools [40]
- d) Decision of selection of D2D pairs candidate will be the responsible of the transmitter (Tx) according to the algorithm that we will use for discovery.

Chapter 3 System Model

3.1 Small area and large area scenarios

In my scenario, I consider emergency situation where BS are damaged, I started first with a small-scale scenario such as stadiums, cinema, theatres or a shopping mall that is covered by 5G macro-cell which is damaged by environmental disaster or terrorist attacks, the rescue team will try to search and find survivals using different algorithms for peer discovery. Figure 14. shows the independency of mobile users for originating the call using ProSe as in [31], although there is a limit for maximum coverage 500 m for discovery as mentioned in Release 12 3GPP standards a rebroadcasting of Beacons is assumed which is still an open research, after that, I tried to apply different algorithms for peer discovery and selection of the best D2D pair accordingly. Then I started to figure out the possibility of using the same Prose in large scale area and compare the results.

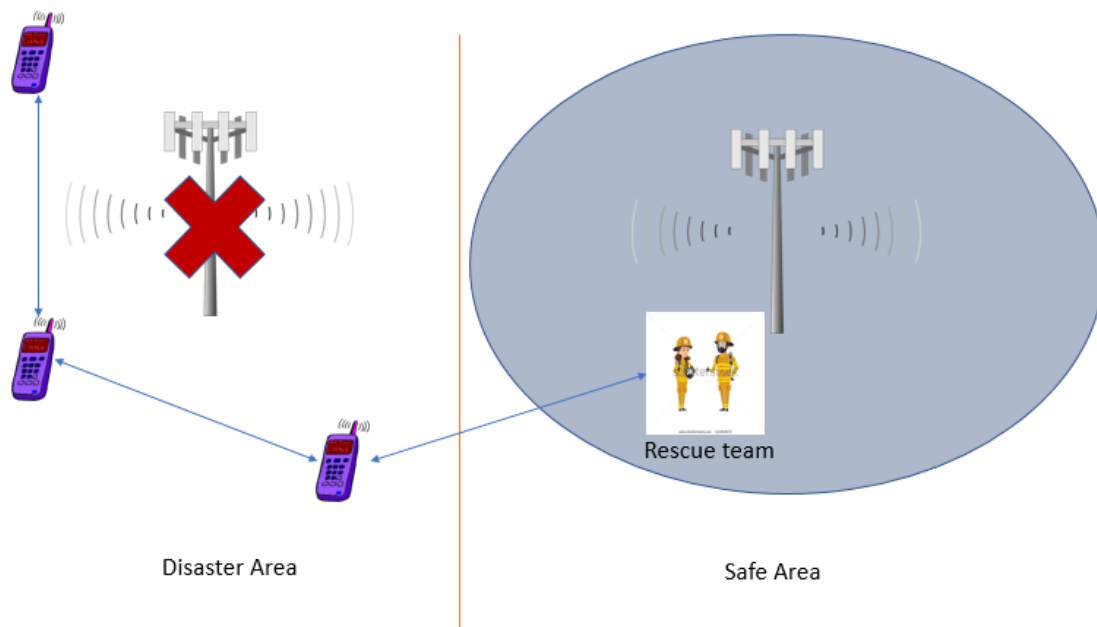

Figure 14. D2D in emergency scenario [41]

By using MATLAB R2016, I started to design Single Cell scenario with BS at the center which is damaged due to a disaster so the edges or the resource allocations by gNodeB are not exist we consider the single cell as a small area without coverage, from Figure 15. we can see the cell coordinates and the BS also CUE which is represented by blue circle just for illustration and knowing the uncovered area parameter, we have N candidate pairs of D2D communication (each red circle represents D2D candidate user) randomly distributed in the area where the BS is Down. Only one Resource blocks (RB) is reused for all communication links so that we can measure the maximum interference in the system

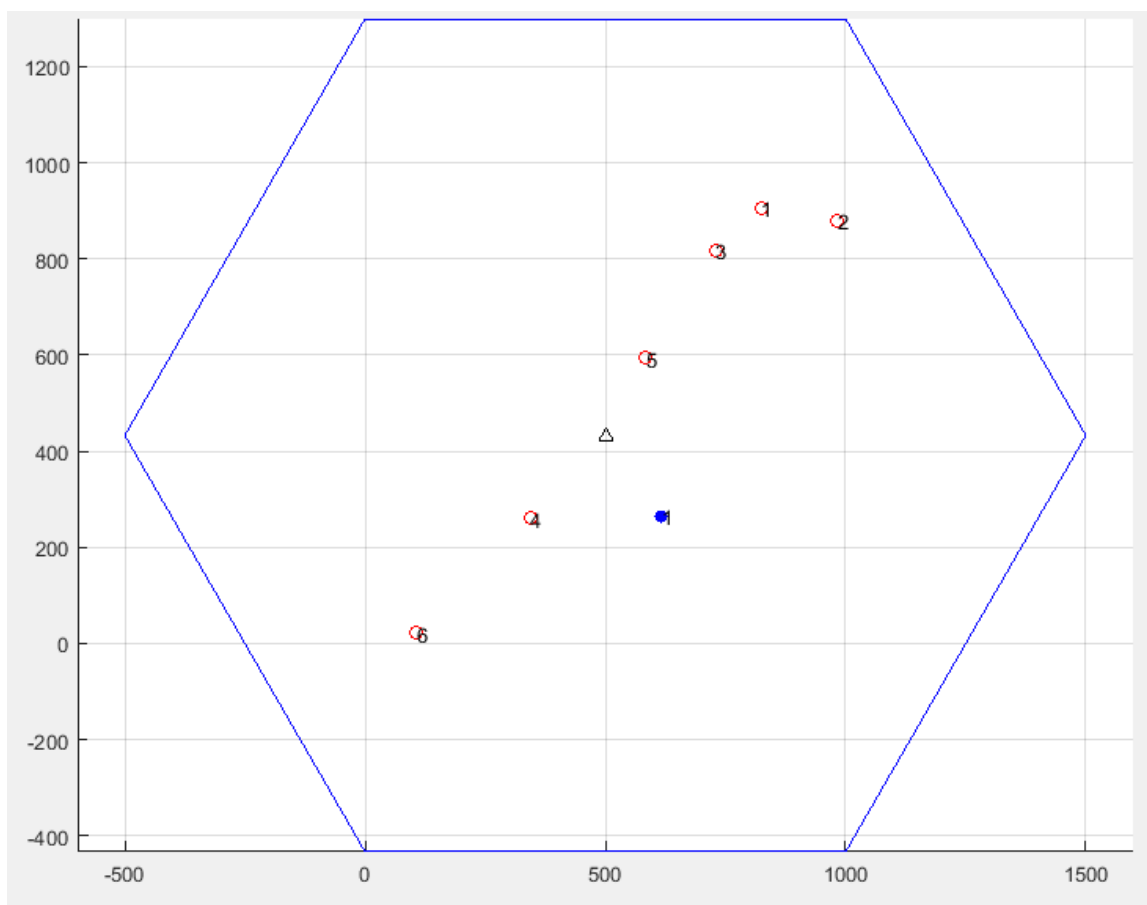

Figure 15. Single cell representation in MATLAB.

3.2 Channel model

Models are needed for wireless system design and operational deployment of such systems, The main three components of Channel model:

3.2.1 Path Loss

It is the relation between the link distance d and the mean attenuation in a given environment

$$A_{PL} = C \left(\frac{d}{d_0} \right)^\gamma$$

Where γ is the path loss exponent, and C is the attenuation at the reference distance $d = d_0$ [32].

3.2.2 Shadowing

It is Random attenuation, fluctuation around the path loss due to presence of large obstacles (buildings, hills,) which shadow the propagation path the large-scale fluctuations of the attenuation are well described by a log-normal distribution.

$$F_A(A_{SH}) = \left(\frac{1}{\sqrt{2\pi\sigma_{SH}^2}} \right) \exp\left(-\frac{(A_S - \mu)^2}{2\sigma_{SH}^2}\right)$$

where variable A_{SH} is the additional attenuation in dB w.r.t. the path loss, μ is the mean and σ_{SH} is the standard deviation in dB

3.2.3 Multipath fading

The multipath attenuation derives from the combination at the receiver of more signal components (reflections or echoes) with phase and amplitude differences. Where α_n and τ_n are the attenuation and the propagation delay of the n -th respectively [42].

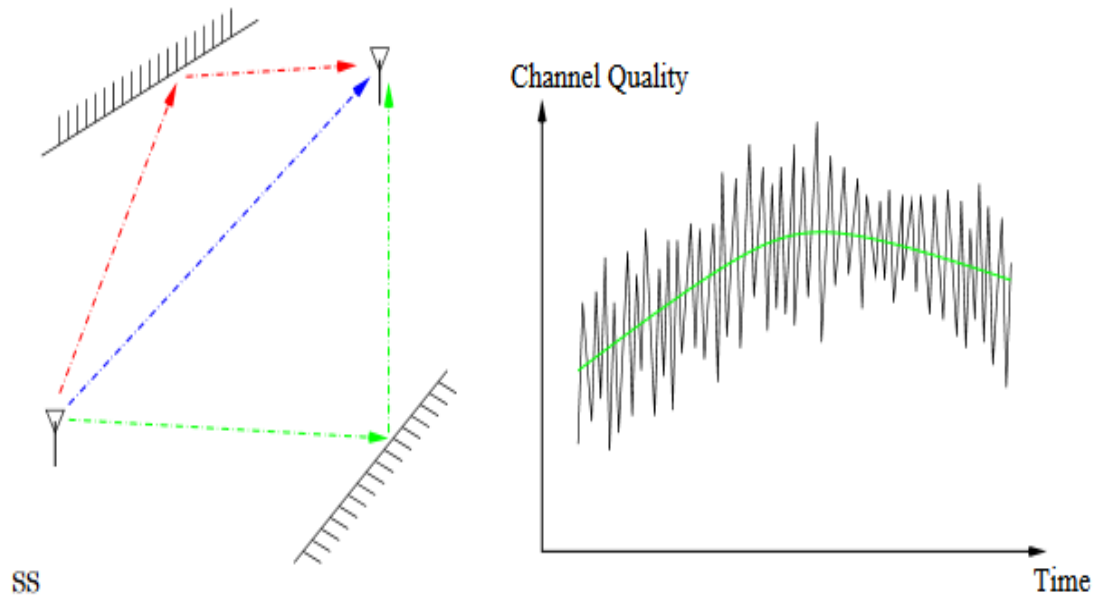

Figure 16. Channel Quality [42]

3.3 SINR Calculations:

One of the main parameters that can Devices or BS can make resource allocations according to it is signal to interference plus noise ratio.

$$\text{SINR} = \frac{P}{I + N}$$

3.3.1 Example for SINR Calculation

- a single cell environment,
- base station is located in the cell center
- one D2D pair
- N cellular users

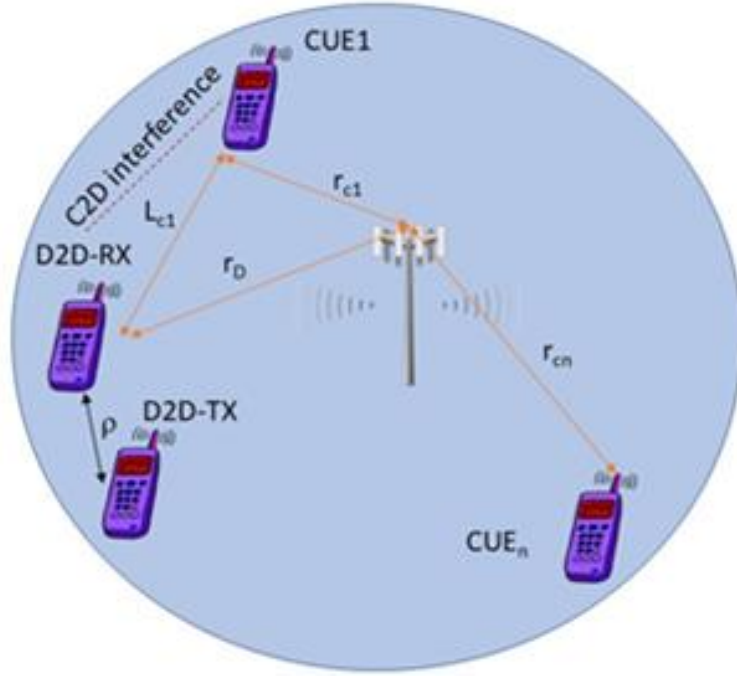

Figure 17. SINR Calculation in single Cell

the distance between the CUE_i and D2D-Rx is given as

$$L_{ci} = \sqrt{(r_{ci}^2 + r_D^2 - 2r_{ci}r_D \cos\theta_i)}$$

r_{ci} = distance between cellular user equipments and base station

r_D = distance between D2D – Rx and base station

$$\theta_i = [0, 2\pi]$$

received signal at the D2D-Rx:

$$y_i = h_D \sqrt{P_D} \rho^{-\alpha} x_D + h_{ci} \sqrt{P_{ci}} L_{ci}^{-\alpha} x_{ci} + N_0$$

h_D = Fading Coefficient in D2D link

h_{ci} = fading coefficient in CUE interference link to D2D Rx

P_D, P_{ci} = are transmit power of D2D – TX and CUE

x_D, x_{ci} = are both signals of D2D – TX and CUE signal to BS

$\alpha = \text{path loss exponent}$

$P_D \rho^{-\alpha} = \text{received power at D2D-Rx for D2D link}$

$P_{C_i} L_{C_i}^{-\alpha} = \text{received power at D2D-Rx for C2D interference link}$

$N_0 = \text{AWGN}$

So SINR:

$$\gamma_{D_i} = \frac{|h_D|^2 P_D \rho^{-\alpha}}{|h_{C_i}|^2 P_{C_i} L_{C_i}^{-\alpha} + N_0}$$

3.3.2 System Model

We calculate the SINR at every D2D receiver (Rx) which have interference signal

$$SINR_{DL} \gamma_{Rx1 \text{ Candidate}} = \frac{P_{D2DTx1 \text{ Candidate}} \cdot G1}{P_{D2D \text{ TX2 Candidate}} \cdot G9 + P_{D2D \text{ TX3}} \cdot G5 + N_0}$$

Where

$$G1 = G_{TX} \cdot G_{RX} \cdot C \cdot L_{C1}^{-\alpha} \cdot |h_{D1}|^2 \cdot \Delta_{SH1}$$

$$G5 = G_{TX} \cdot G_{RX} \cdot C \cdot L_{C5}^{-\alpha} \cdot |h_{C5}|^2 \cdot \Delta_{SH5}$$

$$G9 = G_{TX} \cdot G_{RX} \cdot C \cdot L_{C9}^{-\alpha} \cdot |h_{C9}|^2 \cdot \Delta_{SH9}$$

Interference from eNode B and CUE can be neglected

$$SINR_{DL} \gamma_{Rx2 \text{ Candidate}} = \frac{P_{D2DTx2 \text{ Candidate}} \cdot G3}{P_{D2D \text{ TX1 Candidate}} \cdot G6 + P_{D2D \text{ TX3}} \cdot G7 + N_0}$$

$$G3 = G_{TX} \cdot G_{RX} \cdot C \cdot L_{C3}^{-\alpha} \cdot |h_{C3}|^2 \cdot \Delta_{SH3}$$

$$G6 = G_{TX} \cdot G_{RX} \cdot C \cdot L_{C6}^{-\alpha} \cdot |h_{C6}|^2 \cdot \Delta_{SH6}$$

$$G7 = G_{TX} \cdot G_{RX} \cdot C \cdot L_{C7}^{-\alpha} \cdot |h_{C7}|^2 \cdot \Delta_{SH7}$$

$$SINR \gamma_{D2D \text{ Rx3 Candidate}} = \frac{P_{Tx3D2D \text{ Candidate}} \cdot G2}{P_{D2DTx} \cdot G4 + P_{D2D \text{ Tx}} \cdot G8 + N_0}$$

Where

$$G2 = G_{TX} \cdot G_{RX} \cdot C \cdot L_{C2}^{-\alpha} \cdot |h_{D2}|^2 \cdot \Delta_{SH2}$$

$$G4 = G_{TX} \cdot G_{RX} \cdot C \cdot L_{C4}^{-\alpha} \cdot |h_{C4}|^2 \cdot \Delta_{SH4}$$

$$G8 = G_{TX} \cdot G_{RX} \cdot C \cdot L_{C8}^{-\alpha} \cdot |h_{c8}|^2 \cdot \Delta_{SH8}$$

C = Attenuation at Reference distance

G_{TX} = Antenna TX Gain

G_{RX} = Antenna Rx Gain

Δ_{SHi} = Shadowing

h_{Di} = Fading Coefficient in D2D link

α = path loss exponent

$L_{Ci}^{-\alpha}$ = Path Loss

N_0 = AWGN

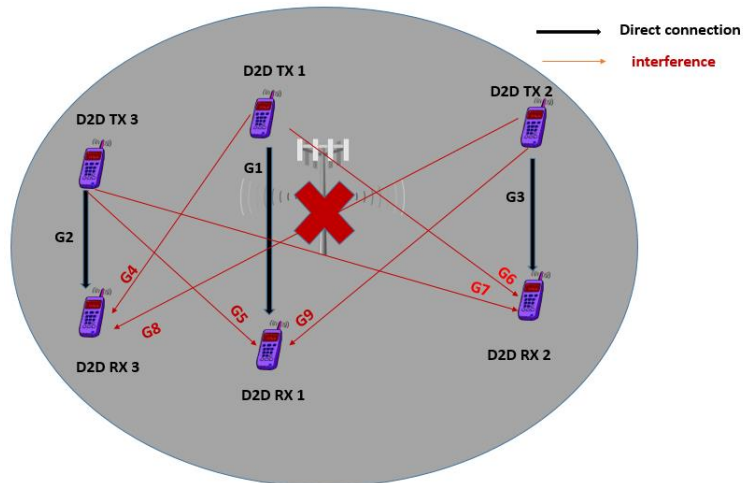

Figure 18. Single cell scenario

Fig. 18 illustrate the calculations of SINR in a small area with no coverage (single cell) using only one RB and as shown in fig.19 we got the SINR values for each iteration which

is the main information that is should broadcasted by the beacons so each D2D creates its table matrices for the next step of selection of D2D pair

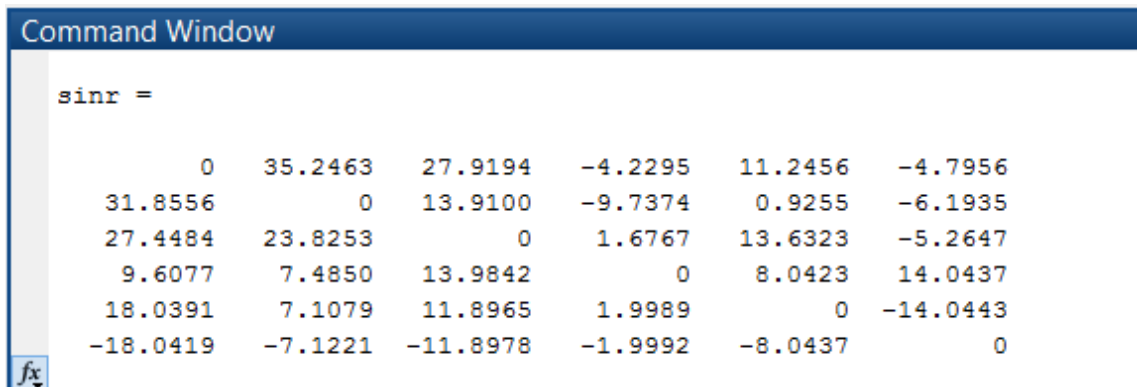

Figure 19. SINR values between D2D Devices using MATLAB.

3.4 Large Scale Area (multicell):

In this scenario the only difference between it and the previous one is the disaster area which is larger, this scenario occur may because of war or in natural disasters like earthquake or volcanic eruptions. I used all the previous parameter but I only changed the size of the area as shown in figure 20.

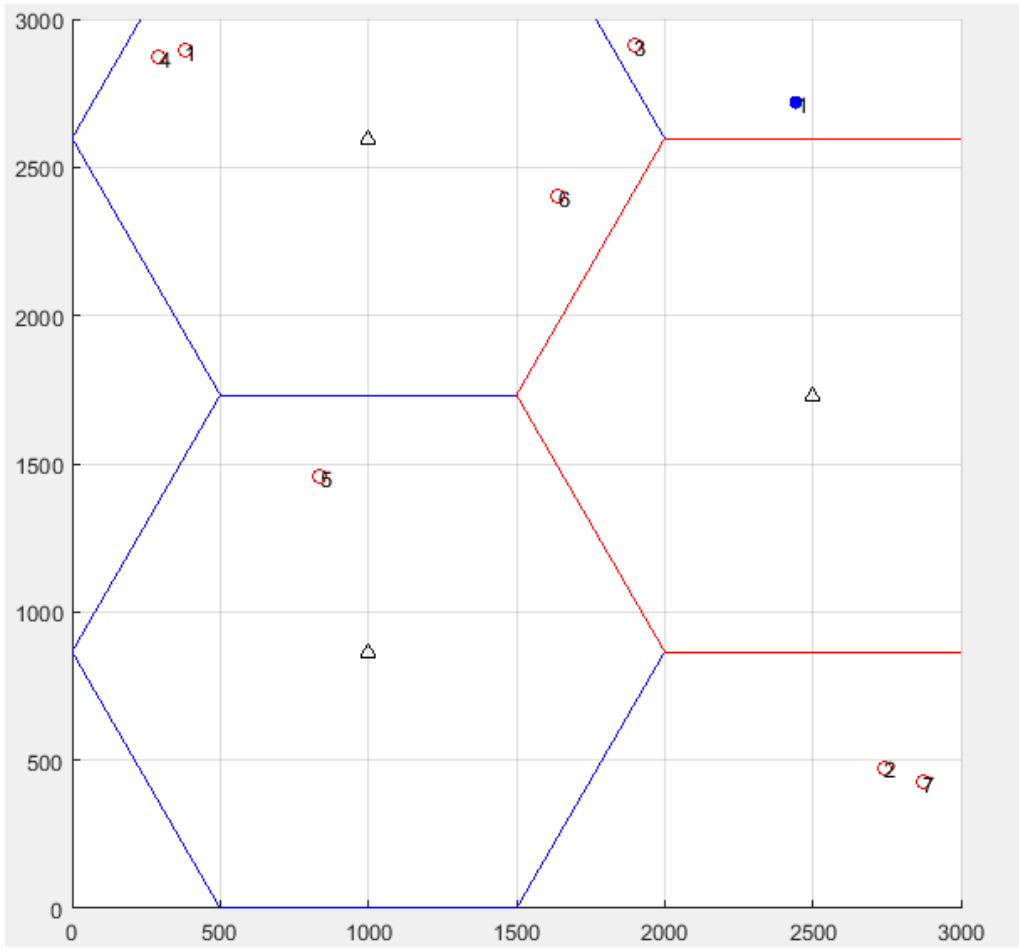

Figure 20. Multicell using MATLAB.

Chapter 4 Algorithms for D2D pair Selection

4.1 Different techniques of selecting D2D pair

4.1.1 Shortest distance of discovery between D2D devices algorithm (SDA)

In this Algorithm selection will be based on the shortest distances between devices neglecting the values of SINR although we have minimum sinr threshold value for the system to work, I started the min. SINR threshold with 0 then 10 and 20 dB for analysis of the differences of increasing SINR threshold on the system. Now we expect to get only one D2D pair and the probability of outage is high related to the number of D2D devices distributed. This algorithm may be used by rescue team D2D devices for searching for survivors in places around them.

SDA illustration:

set counter of D2D pair to zero

inputs: the distances between each device, SINR values between devices

change the values of zero in distance matrices which represent the distance between device and itself to infinity

select the pair of minimum distances between each other

identify the pair number

see if the selected pair meets the minimum SINR threshold

add the value of SINR for the two selected devices

count the number of pair selected

calculate the outage number of pairs

calculate percentage of outage

if there is no pair above threshold

outage is 100%

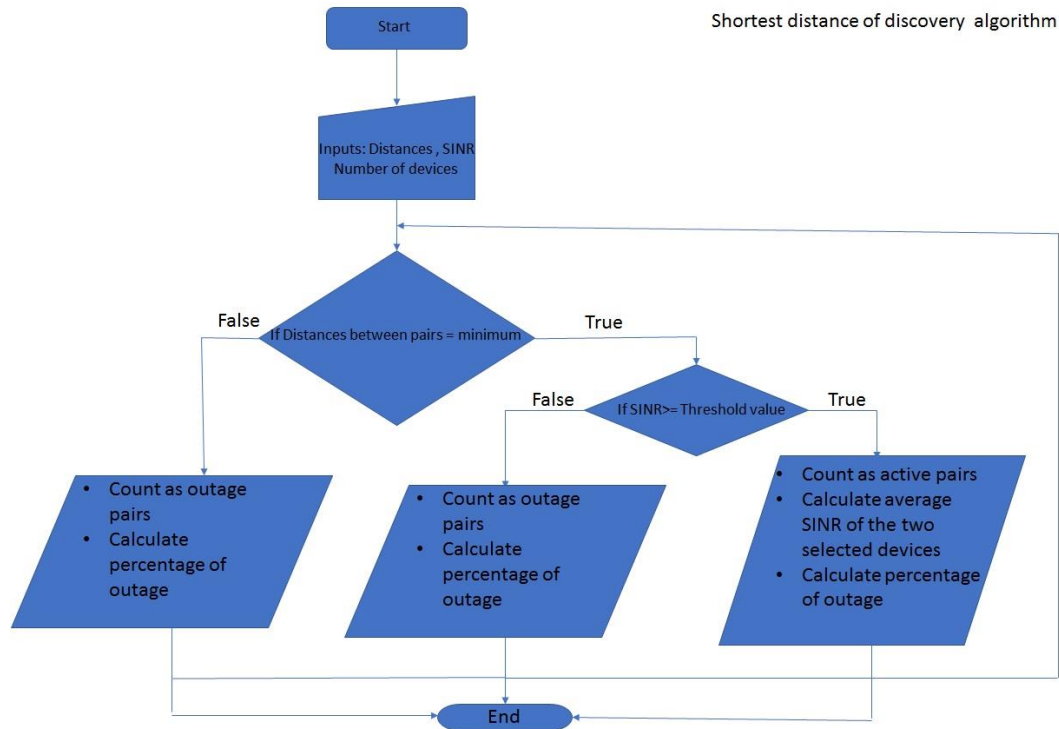

Figure 21. SDA flowchart

4.1.2 Maximum SINR with no limit on distance of discovery algorithm (MSNA):

In this algorithm selection will be based on SINR values, as we choose D2D pair if they meet the minimum threshold of SINR and we select the best pair with maximum SINR values in the two directions, this algorithm may be the best one theoretically as we didn't consider the threshold of the distance of discovery, also if we solve this problem by rebroadcasting of beacons there is a discovery time range and also power limitations are still open points for further research.

MSNA illustration:

set the selected stored values of SINR to zero

a loop to move on number of distributed D2D devices

inputs: SINR between D2D Devices, number of D2D Devices

if the selected devices have SINR higher than 0dB threshold

select all the values of SINR above threshold

select the maximum SINR in the values selected

count number of selected pair

calculate the outage number of D2D pair regarding to the number of D2D devices

calculate the outage percentage

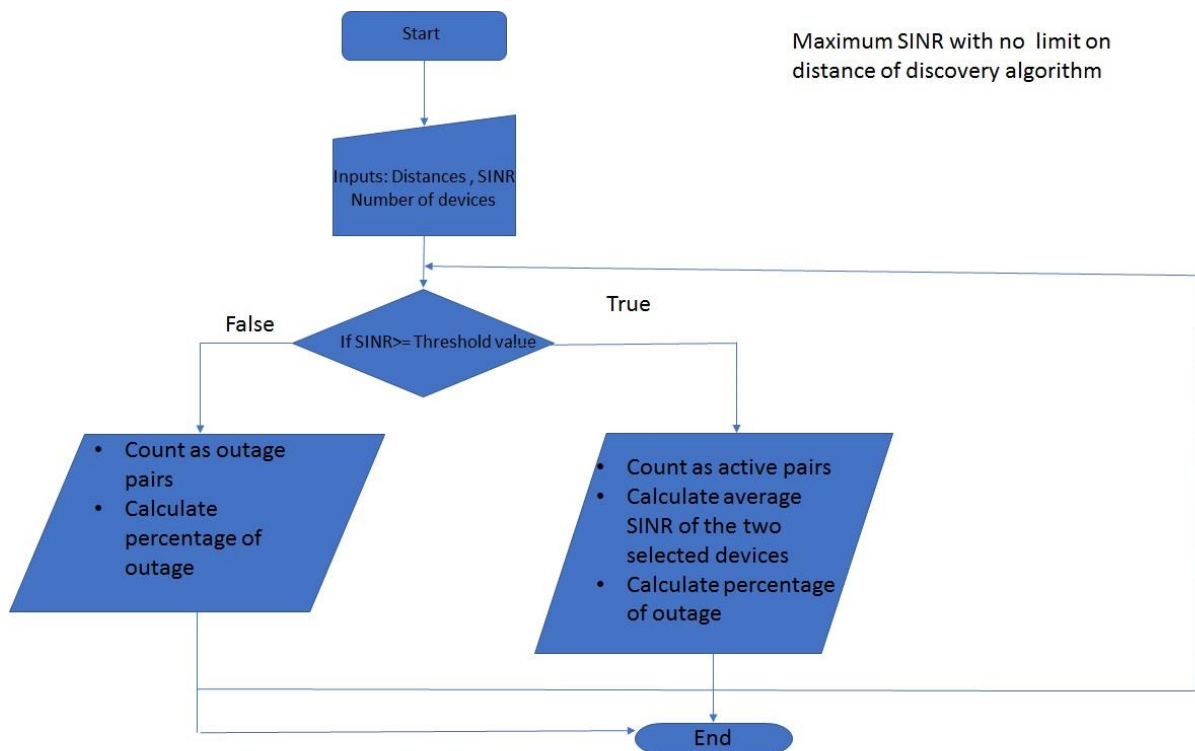

Figure 22. MSNA Flowchart

4.1.3 Maximum SINR with limit on distance of discovery=500m algorithm(MSLA):

In this algorithm distances threshold for mobile discovery is up to 500 m as in LTE Direct standards so we can use this algorithm with portable Base station as in LTE-A

MSLA illustration:

set the counter for D2D pair to zero

Set the selected values for sinr to zero

inputs: Distances between D2D devices and Sinr values and number of D2D devices

#loop to move on number of D2D devices

if the maximum distance between two D2D devices is 500 m

if the SINR values meet the minimum threshold which is above 0 dB

select all the values of SINR above threshold

select the maximum SINR in the values selected

select this D2D pair

count the number of selected D2D pairs

calculate the outage number of D2D pair regarding to the number of D2D devices

calculate the outage percentage

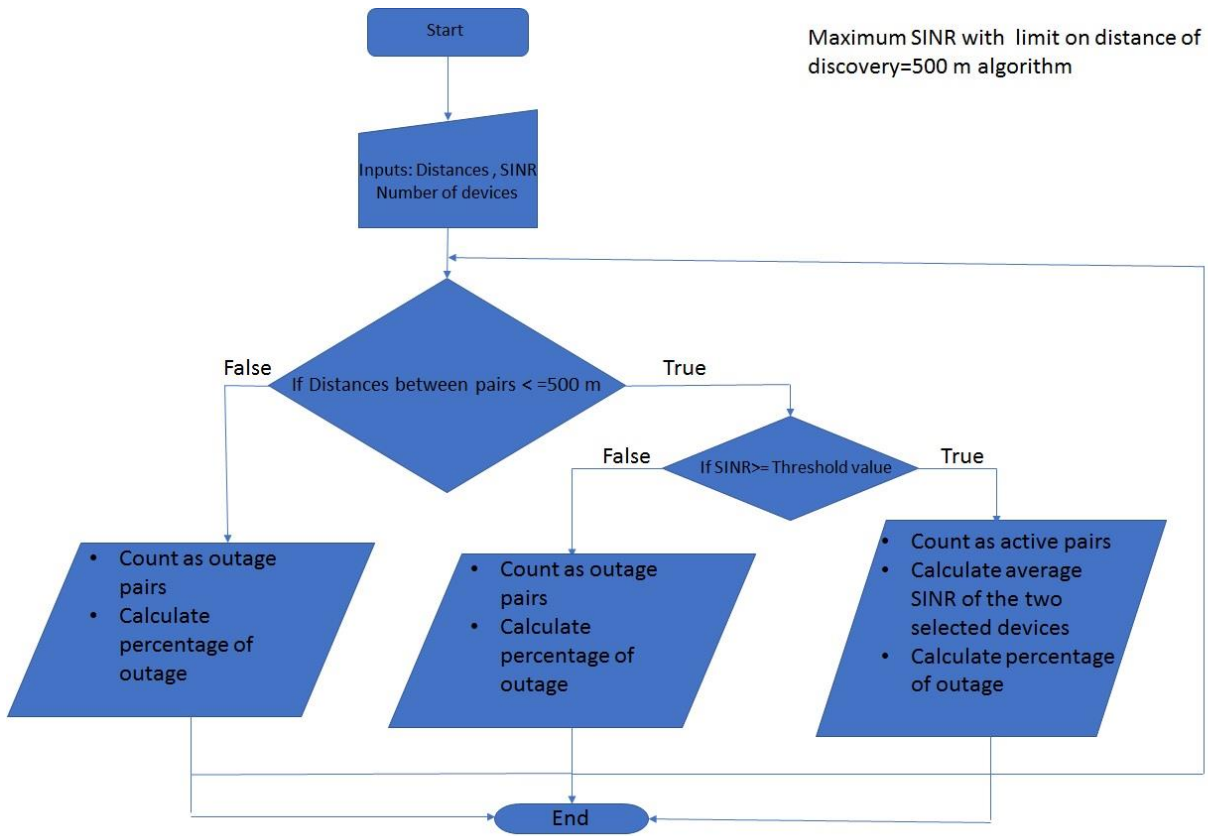

Figure 23. MSLA Flowchart.

Chapter 5 Installation setup and Simulation results

5.1 Installation setup and main parameter

As shown in Table 3, I started to build our wireless channel by adding the main parameters for calculating signal to interference plus noise ratio (SINR), to get reliable measurement we used average values for channel model parameter and also the average results of 400 run for each number of devices randomly distributed also as peer discovery may not discover all the number of candidate devices even with better measurement than selected one, I consider to apply the algorithm of D2D pair selection in random numbers of the distributed devices to get accurate results to what expect in real life scenario. To generate reliable models for future 5G system design, path loss model must be built for link budget and signal strength prediction.

Number of iterations (simulations runs)	400
Fixed Path Loss	30.18
D2D link distances small area (single cell)	Max.2 Km
D2D link distances large area (multicell)	Max 4.3 Km
Path loss exponent	2.6 dB
Shadowing	4 dB
Number of RB	1
Transmitter Gain (G_{Tx})	20-25 dBm
Receiver Gain (G_{Rx})	20-25 dBm
Additive White Gaussian Noise (AWGN)	1-3 dB
Number of D2D Devices	3-15

Table 3. System Main parameter [43]- [44].

Now the system model that I have designed is able to distribute number of D2D devices randomly and calculate the position and the distance between each device as shown in figure 24 and to calculate our main parameter SINR between each D2D device.

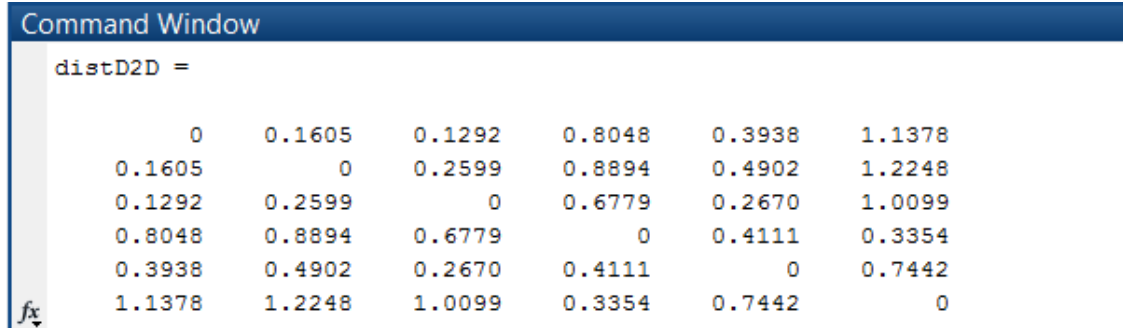

Figure 24. Distance between D2D Devices in MATLAB.

5.2 Simulation Results

5.2.1 Key performance indicators

the ones to be selected for evaluating the performance of D2D communication.

- **throughput:** average data rate during connection time.
- **Energy efficiency:** This measures the gain energy consumption between a D2D connection
- **Latency:** This measures the connection establishment time in D2D situations
- **The signal to interference plus noise ratio:** SINR is defined as the power of a certain signal of interest divided by the sum of the interference power (from all the other interfering signals) and the power of some background noise

Our main reference for performance will be SINR.

5.2.2 Average number of active pair using different algorithm

This is the first plot for multicell and single cell shown in the below Figure 25, **N.B: the plot on the left side represent simulation in multicell and the right side is the single cell also for all next graphs I will represent it in the same sequence.** We have to consider that large Area is the multicell and small area is the single cell because there is

no BTS for creation of cells. In figure 25 we compare the average number of active D2D pairs of distribution different number of devices in disaster situation applying Maximum SINR with no limit on distance of discovery algorithm (MSNA-blue plot representation) and Maximum SINR with limit on distance of discovery=500m Algorithm (MSLA-green plot Representation) in Multicell Scenario (large Scale Area-Macro cells) and Single cell scenario (small scale-Micro Cell). The blue plot represents average number of Active D2D pairs without any condition applied (only SINR must be higher than 0 dB this apply for all selection of D2D pairs) with respect to number of devices. The green plot represents average number of Active D2D pairs with range of coverage between devices is 500 meters applied with respect to number of devices.

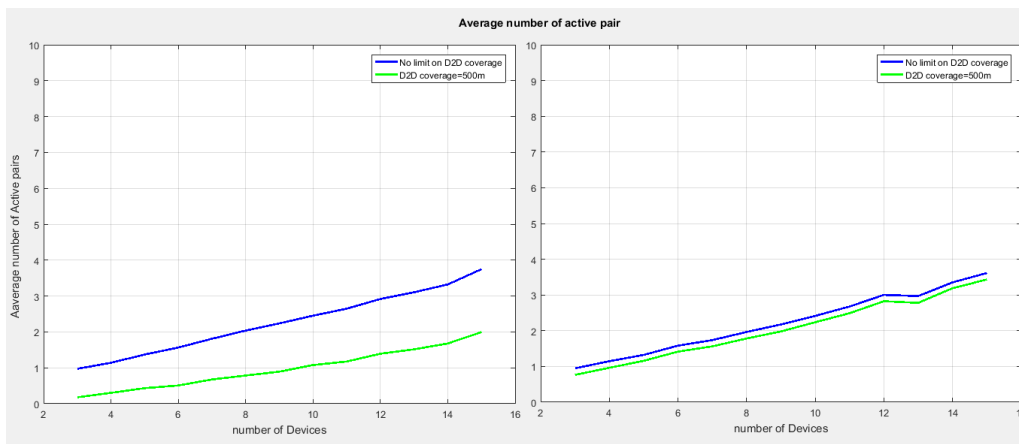

Figure 25. Multicell VS Single cell.

Explanation:

In my observation green plot in multicell is much lower than single cell and this totally correct as in single cell we distribute the devices and maximum distance between devices 2km and green plot represents D2D with maximum distance 500m so the probability to get active D2D pair is higher than multicell as maximum distance between devices is 4 km in multicell. While Blue Plot in Multicell is higher than in Single cell as distribution of mobile devices with probability of low interference with respect to Distances is much higher in Multicell than Single cell as MSNA not depend on distances of discovery. Also, the differences between number of D2D Pairs originated in single cell using both algorithm is low compared to multicell due to increasing of Area and the dependence of MSLA on maximum distance of discovery which is 500 m. We see also that as we

increase number of devices average number of active pair increase (Note: the maximum number of active connections is directly proportional with number of device).

Example: we have 3 devices randomly distributed in single or multicell the maximum connections established is only 1 connection. As we can see from 400 random distribution of devices the average number of active D2D pair

5.2.3 Average SINR

As shown in the below figure 26., The green plot represents the average SINR in two directions as we select the best pair with highest SINR value (MSNA Algorithm). The blue plot represents the average SINR in two directions with restrictions of selection of pairs with maximum distance between devices is 500 meters (MSLA Algorithm) while the red plot represents the average SINR in two directions of pairs of shortest distance between Devices applying shortest distance of discovery Algorithm (SDA)

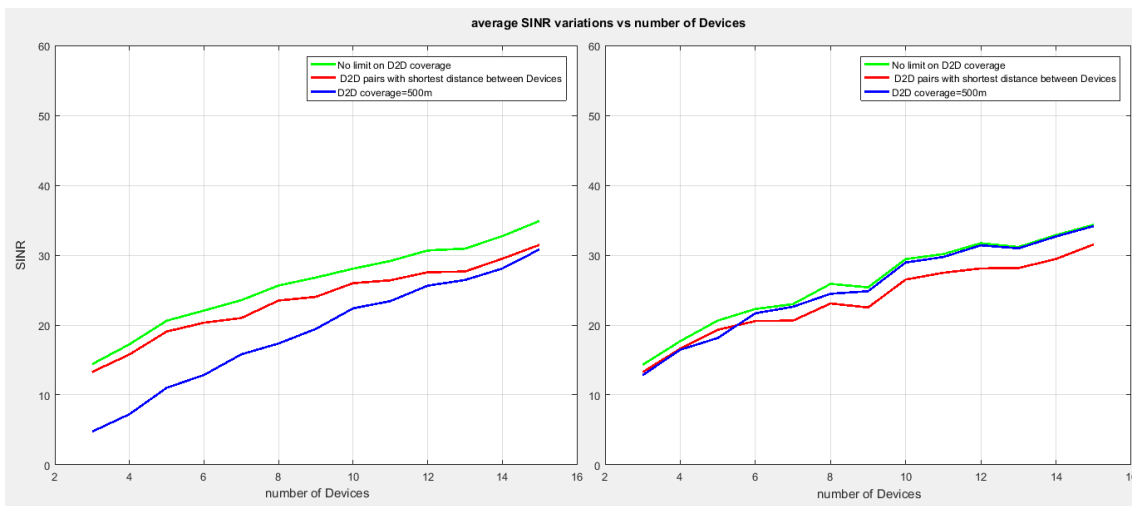

Figure 26. Average SINR using different algorithms VS Number of Devices

Explanation:

Example: if we have 5 devices randomly distributed in single cell or multicell we got the below measurement for SINR

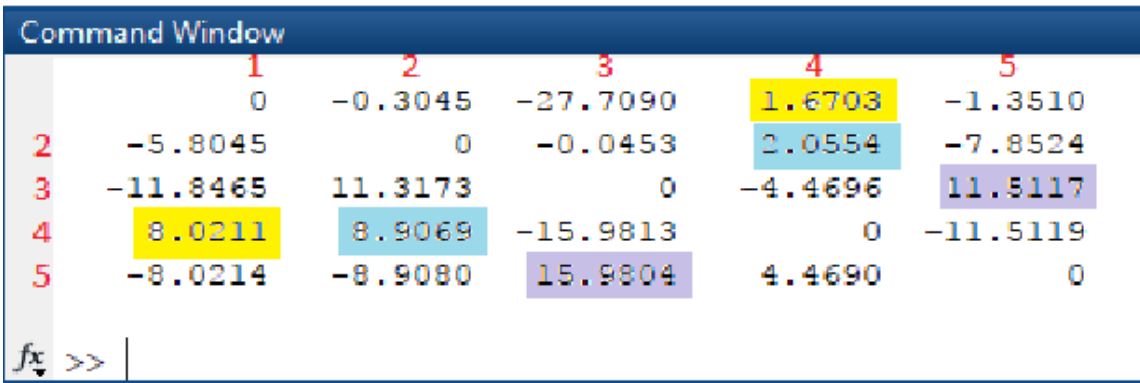

Figure 27. SINR measurements for five Devices using MATLAB

Red color numbers represent rows and columns so if we go in row number 1 column number 1 we have value 0 as (1,1), (2,2), (3,3), (4,4), (5,5) must all have value of zero as devices can't communicate by itself. I go to (1,4) I got the value 1.6703 dB which is the value of SINR when device 1 is connected to 4 measured by RX which is 4 in this scenario, since it's above threshold we have to check (4,1) as we are talking about two ways communications which is 8.0211 dB now I have a candidate D2D pair which can be selected. After making the previous checking for all the pairs I got only the highlighted pairs in the previous figure which are (1,4) ,(4,2),(3,5) (note communication is available in the two directions (1,4) and(4,1) , (4,2) and (2,4) and (3,5) and (5,3) also when we count the number of pairs we consider that if device 1 connect to device 4 so devices 4 and 1 can't connect to other devices so in this example we have only two D2D pairs.

Regarding Fig. 27 if we are still in the previous example the average SINR will be for the D2D pair (3,5) and will be $(11.5117+15.9804)/2=13.746$ this for the green plot representation but if we go to the average SINR with maximum distance of discovery between devices is 500m which is represent by blue plot we have to check the distance first between (1,4), (3,5), (4,2) and selection will be based on this distance and sinr as distances were shown in the below figure 28.:

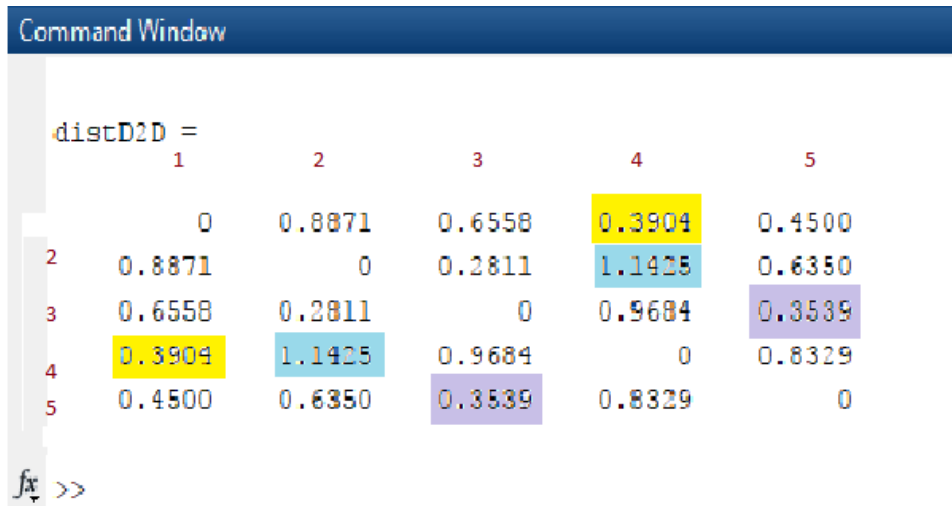

Figure 28. Distances between devices in MATLAB.

Figure 28. represents the distances between devices as we can see (1,4) is equal to (4,1) which is 0.3904 Km which is below 500m for (4,2) is 1.1425 Km which is rejected in the maximum threshold 500m Algorithm, for (3,5) the distance is 0.3539 Km so we also in this scenario we select (3,5) pair and get the average SINR same as in green plot representation also in the shortest distance of discovery algorithm(SDA) represent by red plot as (3,5) pair have the shortest distance for valid pairs. My observation for average SINR variations vs number of Devices using the previous techniques in single cell and multicell: it obvious that Average SINR without restrictions of distances will be the highest in both scenarios (green plot) but in single cell scenario we saw that average SINR of maximum threshold 500 m technique is higher than the shortest distance technique as probability of getting D2D pair with high SINR than D2D pair with shortest distances between them is very high, unlikely in the multicell as may be the shortest distances is 1 or more Km which is rejected in average SINR with 500 m threshold so red plot representation in multicell is higher than the blue one till certain number of devices but by increasing number of devices lead to the normal situation which blue plot goes higher than red one same as single cell scenario

5.2.4 Probability of outage:

In the below figure 29,the Y-axis represent the outage in percentage with respect to number of devices in X-axis distributed randomly so 3.5% for the blue plot which represent the number of D2D pairs without any distance restrictions (MSNA) and is very low percentage and 29% for the red plot which represent the selection of D2D pair

according to the shortest distance between devices (SDA) and 80% in the green plot represents the outage of active D2D pairs using maximum distances between devices 500 m for selection of D2D pairs (MSLA) which means very high outage

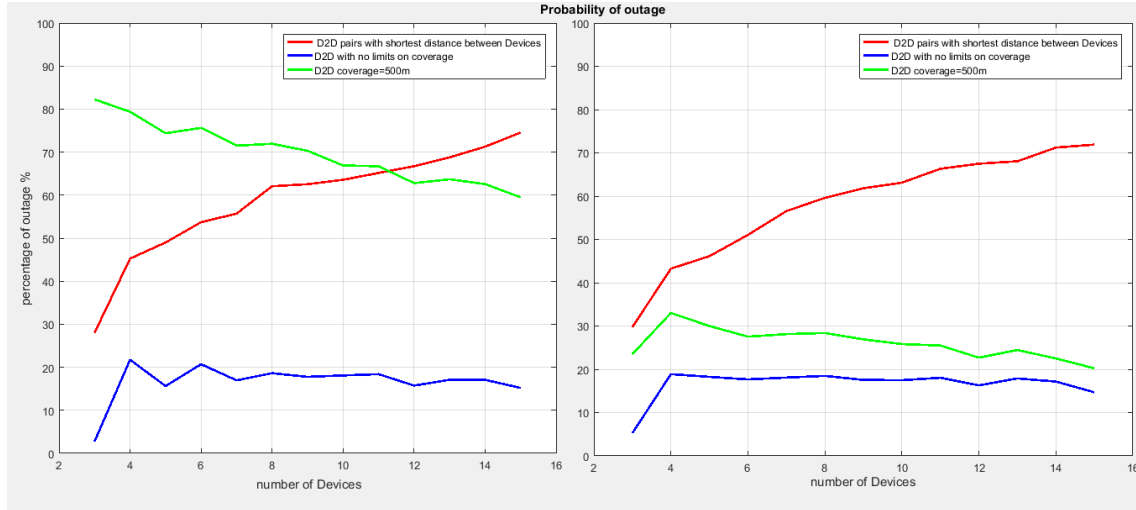

Figure 29. Probability of outage vs Number of Device.

Explanation:

I will start with the single cell from the above figure we can see that the less efficient algorithm to use is the shortest distance Algorithm (SDA) as it will only select one Active D2D pair and neglect all others so as number of devices increase probability of outage increase as shown in the figure 29. as in my calculations for percentage of outage I count the Total number of active D2D pair and subtract from it the number of Active D2D pair selected using the Algorithm and then we get the percentage of outage for each algorithm

Example: If I have 4 Devices then the maximum total number of D2D pairs originated is only 2. Using the shortest distance Algorithm means that the best-case scenario is to have 50% outage as the maximum selection of shortest Distance is only one pair with the shortest distance. We have two factors that is responsible for outage probability (Maximum number of pairs that can be selected and number of devices). If we go also for the Multicell scenario we will observe The green plot represent the outage percentage of active D2D pairs using maximum distances between devices 500 m for selection of D2D pairs is higher than the red plot which represent the shortest distance selection algorithm as I mentioned in multicell the 500m threshold algorithm have low probability of getting active D2D pairs with respect to low number of devices and as this number increase

outage decrease unlikely in the shortest distance algorithm as I mentioned outage increase with the increase of the devices and the figure prove for this case.

5.2.5 Average Number of Active pair for different distances threshold

On figure 30, each plot represent the average no of pairs that is selected using specific number of devices and with respect to maximum distance between devices for pair selection (IDA) in multicell and single cell scenario so we can observe that as number of devices increase the average number of pair increase also as we increase distance threshold between devices the average number of D2D pairs increase and comparing to multicell by increasing the area of mobile distribution this affect the average number of D2D pairs by decreasing it.

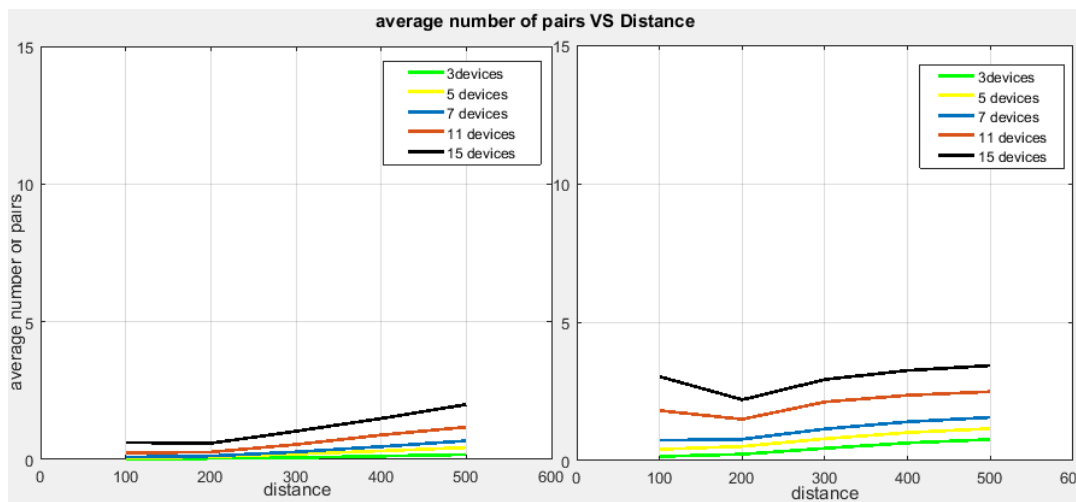

Figure 30. Average number of pairs Vs Distance.

5.2.6 Probability of outage using different distances threshold:

We have 5 plots with different colors as shown in figure 31 which represent the outage percentage vs Distance of discovery between devices variation, each color represent number of D2D devices distributed used in this plot, in multicell and single cell we try to figure out number of devices or distances of discovery has more effect in the outage percentages

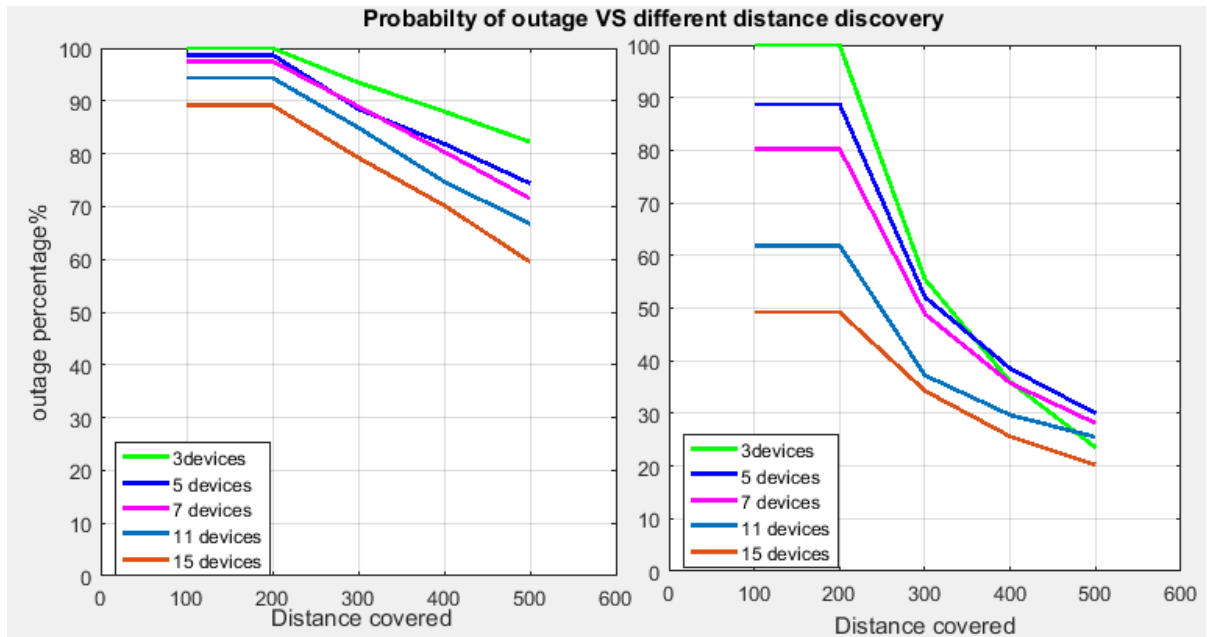

Figure 31. Outage percentage Vs Distance between devices Variation.

Explanation:

My observation to Single cell scenario that as number of Devices increases percentage of outage decreases till 300 meters range of discovery, then at 400 meter we see that percentage of outage for three devices is lower than five and seven devices as the probability of getting one active D2D pair with maximum distance of discovery between devices are 400 meters (as I mentioned before 3 devices make maximum 1 Active D2D pair) is higher than getting two pairs from four devices. And we can see from multicell the percentage of outage is much higher than single cell scenario also the number of devices distributed is inversely proportional with outage percentage until certain distance.

Conclusion: as I mentioned in the previous graphs there are two main factors affect the percentage of outage which are number of devices and the maximum number of pairs originated from this number of devices now in the previous figure we saw the effect of changing maximum threshold with respect to number of devices and calculate the output and we can figure out that increasing and decreasing the distance of discovery threshold between devices have a big effect on percentage of outage.

5.2.7 Outage probability Vs Different distances of discovery threshold

In figure 32. we can see the effect of increasing number of devices with the same distance of discovery between devices. As number of devices increases the probability to get D2D pair is increase and the percentage of outage decreases.

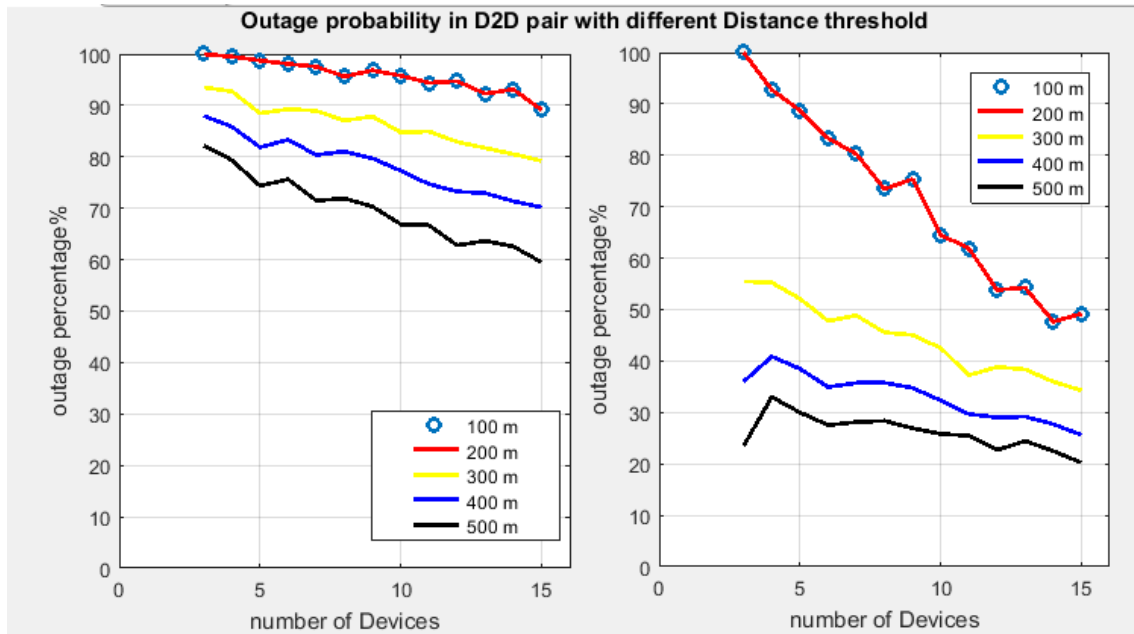

Figure 32. Distance of Discovery Vs Number of Devices.

5.2.8 Increasing SINR threshold:

I started to measure the effect of increasing SINR threshold 0 dB, 10 dB and 20 dB for selection of D2D pairs on the average of number of D2D selected and the outage percentage as we can see from the below figures 33- 34. that increase SINR threshold for selection of D2D pairs will have a great effect on average number of D2D pairs selection which will decrease by increasing SINR threshold and this will lead to high Outage percentage.

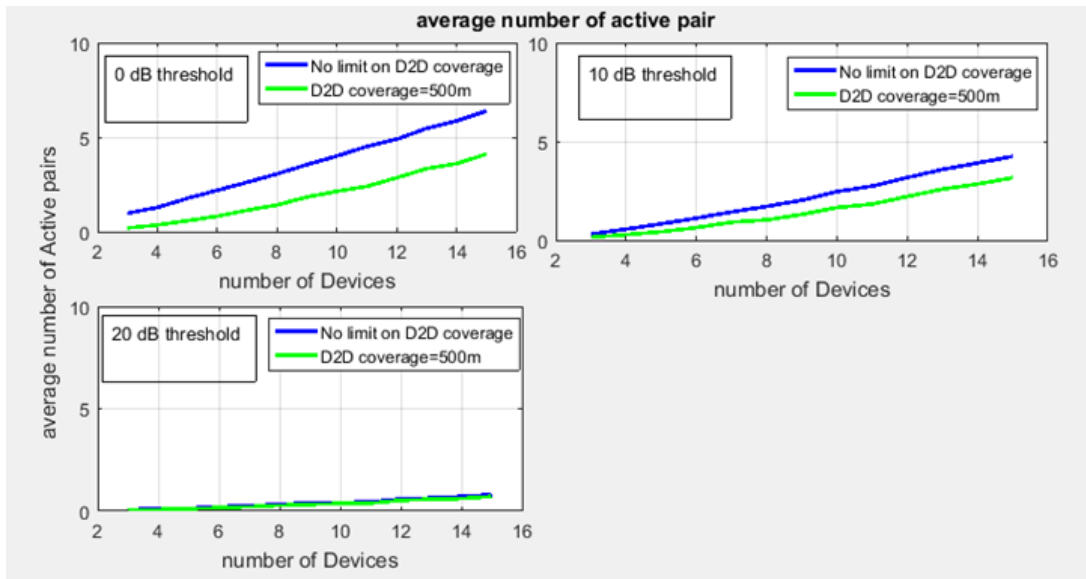

Figure 33. Effect of SINR threshold on average no. of D2D pair.

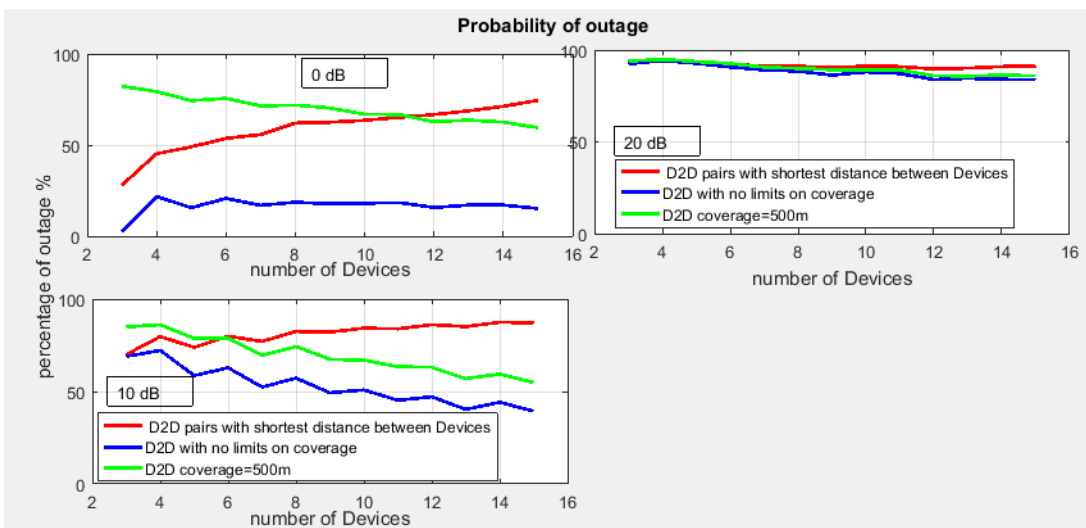

Figure 34. Effect of SINR threshold on outage percentage.

Chapter 6 Conclusions and Future work

6.1 Conclusions

The popularity of mobile communications has increased immensely the past decade. In chapter 1 we performed a survey illustrating the mobile evolution and the improvement in data rate. We argued that mobile operators need innovative solutions to cope with the rising demand of data traffic and that's lead us towards the 5G. our main focus research topic is D2D communications in emergency scenario. A D2D link is a direct connection between two communicating devices. The goal of using D2D links as such is to: (a) increase the spectral efficiency, (b) reduce the load on the network and (c) introduce and facilitate new services. In this thesis we have presented a strategy for direct uncentralized case of device-to-device (D2D) communication in the emergency Scenario. The main normal concept of D2D communication is as follows: the base station (BS) detects when two devices requesting a communication session are in each other's proximity. Then the BS can choose between a cellular- or a D2D link. Multiple D2D links may operate simultaneously, increasing the spectral efficiency. More advantages of D2D- over other technologies and the fulfilment of the requirements of 5G can be seen in figure 1 and Table 1. The D2D sessions take place in the same (licensed) frequency band as the cellular communication or unlicensed band. D2D links interfere with each other. This interference problem is the main challenge when facilitating D2D communications as proposed.

In chapter 2 we explained the concept of device to device communications briefly by knowing the major steps to originate a D2D call like peer discovery and the methods used for peer discovery, resource allocation, interference management and then I explained the Channel quality indicator report and how it is sent through the network then I explained the architecture of D2D in LTE-A and the sidelink channels used for data transfer and control. In chapter 3 I explained the channel model and then I explained how to calculate SINR After that I built our system model on link budget and SINR equations then in

chapter 4: I introduced the main algorithms for selection of D2D pair during peer discovery. These algorithms I choose them based on the emergency scenario. In chapter 5 simulations were performed in two different scenarios using different algorithms to learn more about the selection of D2D pair based on signal quality. We proved that selection of D2D pair based on Maximum SINR is much more efficient than other Algorithms but in special cases like when rescue team in a small area searching for survivals short distance algorithm will be a solution and for normal working network to decrease the overhead on base station or the communication between rescue team in the disaster area MSLA Algorithm will be our ideal case. All our scenarios, under maximum interference that can occur. We explained the relation between the probability of outage and the number of devices. With a rough calculation, we showed that the SINR not depend only on the distance between devices and short distances not a guarantee for good SINR, Finally, we constructed a realistic urban cell scenario for peer discovery and selection of D2D pair in abnormal conditions without the usage of Base station. We empirically derived the probabilities of finding a D2D pair for the given scenario, provided that a minimum SINR requirement of 0, 10 or 20 dB has to be fulfilled at every receiving node. We showed that we can think more for introducing new era that mobile devices can do the work of the networks by their own

6.2 Future work

Research on D2D communication in uncentralized Emergency scenario has been under the attention of scientific researchers for a short time and therefore is in its initial stages. We introduced a novel methodology of selection of D2D pair in the same spectrum. We believe this work provides an appropriate framework for realizing D2D communication in uncentralized emergency scenario. However, future study is required to learn more on the rebroadcasting of beacons and the time frame used in this case. Our simulated scenarios in chapter 5 assume rebroadcasting in two of the Algorithms applied (MSNA-SDA), whereas in reality maximum distance of discovery is 500 m without rebroadcasting of beacons also to learn more on the interactions between the performance of our system and User mobility. Our simulated scenarios in chapter 5 assume static nodes, whereas in reality nodes might be moving. The dynamics as consequence of moving nodes is a topic for further study as nodes might be moving. A more detailed research on the necessary protocols and the overhead caused by the signalling is required. Signal model and system parameters: All our simulations have been performed with the parameters stated in table

(3). By changing these parameters different results are obtained. A research on the relation between the system parameters and the performance can be performed.

References:

- [1] http://www.akosrs.si/files/Telekomunikacije/Digitalna_agenda/Internetni_protokol_Ipv6/More-than-50-billion-connected-devices.pdf [last access 26-11-2017].
- [2] E. Ezhilarasan and M. Dinakaran, "A Review on Mobile Technologies: 3G, 4G and 5G," 2017 Second International Conference on Recent Trends and Challenges in Computational Models (ICRTCCM), Tindivanam, Ieee 2017, pp. 369-37
- [3] A. R. Mishra, Fundamentals of Cellular Network Planning and Optimization: 2G / 2.5G / 3G Evolution to 4G. Chichester, West Sussex, England: John Wiley & Sons Ltd, published 24 nov 2006
- [4] A. Gupta and R. K. Jha, "A Survey of 5G Network: Architecture and Emerging Technologies," in IEEE Access, vol. 3, pp. 1206-1232, 2015.
- [5] K. Ali, H. X. Nguyen, P. Shah, Q. T. Vien and N. Bhuvanandaram, "Architecture for public safety network using D2D communication," 2016 IEEE Wireless Communications and Networking Conference Workshops (WCNCW), Doha, 2016, pp. 206-211
- [6] O. Galinina, A. Pyattaev, S. Andreev, M. Dohler and Y. Koucheryavy, "5G Multi-RAT LTE-WIFI Ultra-Dense Small Cells: Performance Dynamics, Architecture, and Trends," in IEEE Journal on Selected Areas in Communications, vol. 33, no. 6, June 2015, pp. 1224-1240.
- [7] Larsson, E.G Edfors, O. Tufvesson, F & Marzetta, 'Massive MIMO for Next Generation Wireless Systems' IEEE Communications Magazine, vol 52, no. 2, TL 2014, pp. 186-195.
- [8] S. D. Hayward, "Adaptive beamforming for rapidly moving arrays," Proceedings of International Radar Conference, Beijing, 1996, pp. 480-483

- [9] A.Arash,W. Qing, M. Vincenzo ‘A survey on device-to-device communication in cellular networks. IEEE Common. Magazine, vol.6,2014,
- [10] S. Ahmadi, "An overview of next-generation mobile WiMAX technology," in IEEE Communications Magazine, vol. 47, no. 6, pp. 84-98, June 2009.
- [11] S. Jimaa, Kok Keong Chai, Yue Chen and Y. Alfadhl, "LTE-A an overview and future research areas," 2011 IEEE 7th International Conference on Wireless and Mobile Computing, Networking and Communications (WiMob), Wuhan, 2011, pp. 395-399.
- [12] <https://the8layers.com/2016/10/26/5g-terminology-gnb> [last access 27-12-2017]
- [13] L. Babun, A. İ. Yürekli and İ. Güvenç, "Multi-hop and D2D communications for extending coverage in public safety scenarios," 2015 IEEE 40th Local Computer Networks Conference Workshops (LCN Workshops), Clearwater Beach, FL, 2015, pp. 912-919.
- [14] A. Abu Al Haija and M. Vu, "Spectral Efficiency and Outage Performance for Hybrid D2D Infrastructure Uplink Cooperation," in IEEE Transactions on Wireless Communications, vol. 14, no. 3, pp. 1183-1198, March 2015.
- [15] X. Lin, J. G. Andrews and A. Ghosh, "Spectrum Sharing for Device-to-Device Communication in Cellular Networks," in IEEE Transactions on Wireless Communications, vol. 13, no. 12, pp. 6727-6740, Dec. 2014
- [16] Peng, Bo & Hu, Chunjing & Peng, Tao & Yang, Yang & Wang, WgNBo. (2013). A resource allocation scheme for D2D multicast with QoS protection in OFDMA-based systems. PP.12383-2387.
- [17] B. Zhang, Y. Li, D. Jin, P. Hui and Z. Han, "Social-Aware Peer Discovery for D2D Communications Underlying Cellular Networks," in IEEE Transactions on Wireless Communications, vol. 14, no. 5, pp. 2426-2439, May 2015.
- [18] G. Rigazzi, N. Pratas, P. Pevoski, R. Fantacci, Aggregation and Trunking of M2M Traffic via D2D Connections, Mobile and Wireless Networking Symposium 2015

- [19] S. Mikki, M. Kamoun and M. Sarkiss, "Device-to-device communication for capacity enhancement in cellular networks," 2014 IEEE Wireless Communications and Networking Conference (WCNC), Istanbul, 2014, pp. 496-501.
- [20] S.H Kang, H. G Cho, D. Lim Method for communicating between wireless devices and wireless device using same, patent, no. US 9565545
- [21] P.Gandotra, R.K Jha ,Device-to-Device Communication in Cellular Networks: A Survey, Journal of Network and Computer Applications Volume 71, August 2016, Pages 99-117
- [22] <http://www.3gpteinfo.com/lte-direct/>[last access 26/11/2017]
- [23] Alam, Muhammad Mahtab and Arbia, Dhafer Ben and Hamida, Elyes Ben, "Research Trends in Multi-Standard Device-to-Device Communication in Wearable Wireless Networks", In proceedings of workshop on Cognitive Radio for 5G Networks, 10th International Conference on Cognitive Radio Oriented Wireless Networks (CROWNCOM), PP. 735-746, 2015
- [24] L. Jedidi, F. Louati, M. Chekir and H. Besbes, "D2D discovery approach based on spreading technique for public safety," *2017 Wireless Days*, Porto, 2017, pp. 224-226.
- [25] S. Sun, Q. Gao, W. Chen, R. Zhao and Y. Peng, "Recent progress of long-term evolution device-to-device in third-generation partnership project standardisation," in *IET Communications*, vol. 9, no. 3, pp. 412-420, 2 12 2015
- [26] A. Prasad, A. Kunz, G. Velez, K. Samdanis and J. Song, "Energy-Efficient D2D Discovery for Proximity Services in 3GPP LTE-Advanced Networks: ProSe Discovery Mechanisms," in *IEEE Vehicular Technology Magazine*, vol. 9, no. 4, pp. 40-50, Dec. 2014.
- [27] Z. Liu, T. Peng, S. Xiang and W. Wang, "Mode selection for Device-to-Device (D2D) communication under LTE-Advanced networks," 2012 IEEE International Conference on Communications (ICC), Ottawa, ON, 2012, pp. 5563-5567.

- [28] W. Lee, J. Kim and S. W. Choi, "New D2D Peer Discovery Scheme Based on Spatial Correlation of Wireless Channel," in *IEEE Transactions on Vehicular Technology*, vol. 65, no. 12, pp. 10120-10125, Dec. 2016.
- [29] M.Noura, R. Nordin, A survey on interference management for Device-to-Device (D2D) communication and its challenges in 5G networks, *Journal of Network and Computer Applications* Volume 71, August 2016, Pages 130-150
- [30] S. A. Abd, Manjunath S. S. and S. Abdulhayan, "Direct Device-to-Device communication in 5G Networks," 2016 International Conference on Computation System and Information Technology for Sustainable Solutions (CSITSS), Bangalore, 2016, pp. 216-219.
- [31] Doumiati, Salam & Artail, Hassan & Gutierrez-Estevez, David. (2014). A Framework for LTE-A Proximity-based Device-to-Device Service Registration and Discovery. *Procedia Computer Science*. PP 87–94.
- [32] V. Venkata Subramanian, F. S. Moya and K. Pawlak, "Centralized and decentralized multi-cell D2D resource allocation using flexible UL/DL TDD," 2015 IEEE Wireless Communications and Networking Conference Workshops (WCNCW), New Orleans, LA, 2015, pp. 305-310.
- [33] <http://www.sharetechnote.com>, illustration of LTE 3GPP standards [last access 26-11-2017]
- [34] 3GPP, "Evolved Universal Terrestrial Radio Access (EUTRA); Services provided by the physical layer" 3rd Generation Partnership Project (3GPP), TS 36.302, Version 12.6.0 Release 12, January 2016
- [35] 3GPP, "Physical Channels and Modulation," 3rd Generation Partnership Project (3GPP), TS 36.211 V8.9.0
- [36] S.Dominic and L. Jacob, "Distributed Resource Allocation for D2D Communications Underlying Cellular Networks in Time-Varying Environment," in *IEEE Communications Letters*, vol. PP, no. 99, pp. 1-1.

- [37] Khan, Muhidul Islam and Alam, Muhammad Mahtab and Moullec, Yannick Le and Yaacoub, Elias, "Throughput-Aware Cooperative Reinforcement Learning for Adaptive Resource Allocation in Device-to-Device Communication", MDPI, Future Internet Journal, 9 (4), 2017
- [38] PEIYUE ZHAO, Radio Resource Management Algorithms for D2D Communications with Limited Channel State Information, Royal institute of Technology, Master's Thesis
- [39] Y. Luo, L. Cui, Y. Yang and B. Gao, "Power control and channel access for physical-layer security of D2D underlay communication," 2015 International Conference on Wireless Communications & Signal Processing (WCSP), Nanjing, 2015, pp. 1-5.
- [40] S. Martinez Lopez, An overview of D2D in 3GPP LTE Standard, Orange, 21st of June 2016
- [41] K. Ali, H. X. Nguyen, P. Shah, Q. T. Vien and N. Bhuvanansundaram, "Architecture for public safety network using D2D communication," 2016 IEEE Wireless Communications and Networking Conference Workshops (WCNCW), Doha, 2016, pp. 206-211
- [42] David Tse, Fundamentals of Wireless Communications “, University of California, Berkeley Pramod Viswanath, University of Illinois, Urbana-Champaign
- [43] S. Sun, T. A. Thomas, T. S. Rappaport, H. Nguyen, I. Z. Kovacs and I. Rodriguez, "Path Loss, Shadow Fading, and Line-of-Sight Probability Models for 5G Urban Macro-Cellular Scenarios," 2015 IEEE Globecom Workshops (GC Wkshps), San Diego, CA, 2015, pp. 1-7.
- [44] 3GPP, “Study on channel model for frequency spectrum above 6 GHz,” 3rd Generation Partnership Project (3GPP), TR 38.900 V14.2.0, Dec. 2016.

Appendix – D2D in 5G paper

2016 International Conference on Computational Systems and Information Systems for Sustainable Solutions

Direct Device-to-Device Communication in 5G Networks

Senan Ali Abd

PhD Research Scholar, MCA Department,
Dayananda Sagar College of Engineering
Bangalore, India
senanali73@yahoo.com

Dr. Manjunath.S.S

Prof & Head, IS Department
DSCE,
Bangalore, India
mnLss2002@yahoo.co.in

Dr. Sayed Abdulhayan

Asso. Prof, Telecom Dept,
DSCE,
Bangalore, India
sabdulhayan@gmail.com

Abstract-Device-to-Device technology is the contemporary technology to Machine-to-Machine communication Technology in 5th Generation. The specification given in the 3GPP speaks about different Interfaces and layering in D2D communication in 5th Generation. The Devices considered for communication in 5G technology are User Equipment, eNodeB, MME etc but the simulation we carried out in our experiment is between UE and UE. In our Experimentation we were able to transfer the Images from one UE to the required UE with IP protocol for Networking. We are employing Matlab Simulation for D2D communication between UEs. This paper discusses the transaction carried out in Matlab according to 3GPP Specification under 5G scenario.

Keywords--UE-User Equipment, eNodeB-Evolved Node B, MME-Mobility Management Entity, D2D-Device to Device communication technology, LTE-Advanced-Long Term Evolution Technology for 5th Generation and MANET-Mobile Adhoc Networks.

I. INTRODUCTION

THIS Transaction paper demonstrates about the Image Transfer in MANETs.

MANETs are infrastructureless, with no dedicated Bandwidth allocated to it for Transmission of Data Traffic or Control Traffic. Hence its only applicability will be for small amount of data i.e. Maximum in Kilo bits. But whenever we consider an image to be transferred in MANETs, it appears to be extremely rare scenario to be take place. But the new technology of D2D communication which is client technology of 5th Generation Communication will be an answer to this type of Image Transfer through MANETs. The difference between the earlier technologies and The D2D is, D2D technology is supported with dedicated Bandwidth and supporting Channels for Traffic Communication between Devices which are nothing but UEs in our Experiment. Here there are dedicated channels for Data and Control traffic. The 3GPP specifications of LTE-A of Release 2014 and Release 2015 are supporting D2D communication with dedicated Channel. Based on these 3GPP test specifications we have setup our simulation in Matlab.

The Paper is Organized as mentioned: Section-I IS introduction which speaks about the details of experiment conducted and also the organization of Paper into

test specifications with its interfaces and terminologies employed for this type of D2D communication. Section-III explains the results got in the experimental Simulation Scenario. Section-IV deals with the short comings and limitations of the experiment conducted. Section-V discusses the future enhancement in the simulation Scenario. Section-VI tells about the conclusion of the Experiment conducted.

IT. 3GPP SPECIFICATION SCENARIO FOR D2D

In 3GPP Scenario UEs, eNodeBs and MME are all the Devices. Its includes the functional blocks of UEs, E-UTRAN (Evolved Universal Terrestrial Radio Network) consisting of eNodes, and EPC (Evolved Packet Core) consisting of MMEs. In D2D communication the discovery and data Transfer from one UE to another UE is configured by either EUTRAN i.e. eNodeB or EPC i.e. MME. Here their is Direct Communication between the UE and another UE is also Possible with PC5 Interface as mentioned in 3GPP specification. The discovery of Device and data Transfer all will be taking place with ProSe Technology which is the proximity Communication Technology. This Communication will be taking Place under the supervision of eNodeB or MME [1-4].

We are employing ProSe Server for communication between devices and EPC. The Figure.1 show the Interfaces and the four functional entities which take part in D2D communication. The E-UTRAN, EPC, ProSe Function Server acts as different entities in the Communication Modes. But we have specifically chosen of Direct ProSe Discover and Direct Communication from UE to UE using PC5 Interface [1-4].

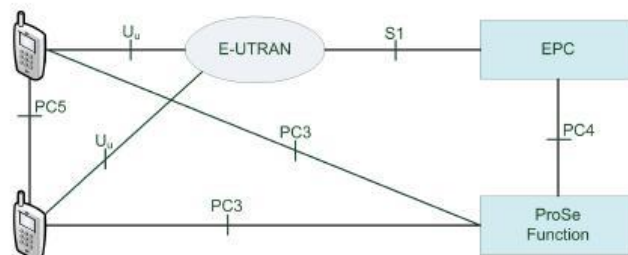

Fig.1-Interfaces and Entities in D2D in 5G

PC5-Direct Ue-to-UE Interface
 PC3-Interface between UE and ProSe Server
 PC4-Interface between ProSe server and EPC
 SI-Interface between EUTRAN and EPC
 Uu-Interface between UE and EUTRAN

In our Experiment we simulated for only PC5 Interface without the authorization from EUTRAN and EPC.

The 3GPP Test Specification specified in Release-14 and Release-15 speaks of dedicated channels for ProSe discover and ProSe communication between Devices. The Fig.2 show the different control and Data Channels used in ProSe Communication in D2D communication[1-4].

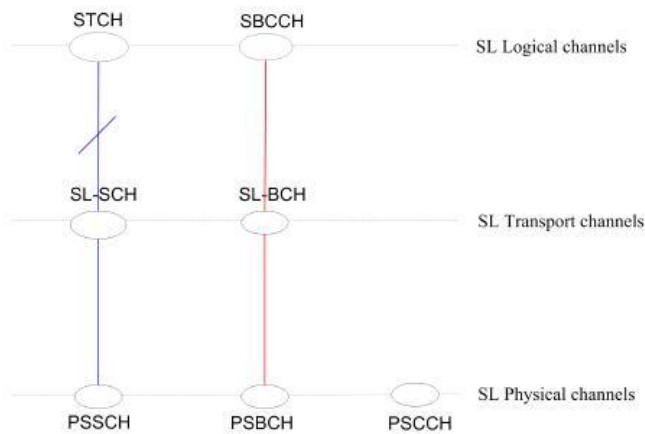

Fig.2-Dedicated (Red Control and Blue Data Channels) in different Layer for ProSe Communication

Sidelink Physical Layer Channel operate in Physical layer, Sidelink Transport Channels operate in MAC(Medium Access Control) layer and Sidelink Logical Channels operate in RLC(Radio Link Control) layers. Let us now find what are those dedicated Channel in Different Layers[1-4].

1) Physical Layer:

PSSCH:Physical Sidelink Shared Control Channel(Data Channel)

PSBCH:Physical Sidelink Broadcast Channel(Control Channel used in Direct

Discovery in D2D) PSCCH:Physical Sidelink Control Channel(Control Channel)

2) MAC Layer:

SLBCH:Sidelink Broadcast Channel(Control).

SLSCH:Sidelink Shared Channel(Data).

1) RLC Layer:

STCH:Sidelink Traffic Channel(Data). SBCCH:Sidelink Broadcast Control

Channel(Control Channel for Direct Discovery in D2D).

We had implemented the experiment in terms of Sidelink Channel. Side Link channels are those which are exclusively taken from Uplink Channels. Because the Downlink Channel have a limited Bandwidth to support thousands of UEs in a Cell. So the Downlink Channels are always busy either in data or Control information Transfer. Hence in 3GPP uplink Channels are preferred for communication between D2D.This is because most of the PRBs (Physical Resource Blocks) are left unused in Uplink. Hence we can utilize the free PRBs for our D2D communication. But these Uplink Channels are also meant to support Uplink cellular traffic. Hence we need to Reserve the PRB in Cellular and D2D technologies as per mentioned in 3GPP test Specification. Every Uplink Control and Data Channel is being exclusively reserved for both Cellular Traffic and D2D traffic in terms of PRBs. Then This Uplink Channels are named as Sidelink Channel what we meant for communication in D2D.The Fig.3 depict the sidelink Channels for D2D communication with ProSe technology[1-4].



Fig.3-ProSe Sidelink Channels with PC5 Interface.

The Channel which are named as Sidelink Channel will be accommodating both Cellular Traffic as well as D2D communication Traffic with exclusively reserved PRBs in each and every channel. Let us have a look at one of side link Channel PRB distribution, which catering both Cellular traffic as well as D2D communication. PUCCH stands for Physical Uplink Control Channel, which carries the control Information. Here in FigA we can see that some of PRBs (Physical Resource Blocks) are reserved for Cellular Traffic and some are reserved for D2D communication using PC5 Interface [1-4].

The PRBs reservation is necessary since the UE Device has to cater for both the kind of Traffic i.e Cellular as well as D2D Communication using PC5 Interface. This is done to avoid the conflict between Cellular and D2D Networks[1-4].

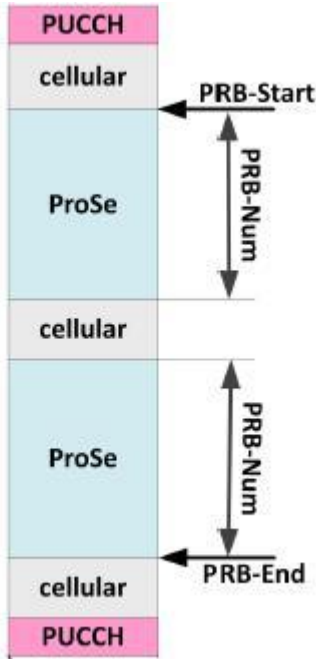

FigA-PRBs reserved as per Cellular and D2D traffic for PUCCH.

The Protocol Stack Layer does not include RRC(Radio Resource Control Layer) which is required for the PC3 and SI Interface. This is because in our experiment we are considering only Direct ProSe discovery with Direct Communication between UEs. The Requirement of Control Channels from RRC layer are not required in our experimentation as we are not experimenting on S 1 Interface between EUTRAN and UEs[1A].

The NAS Layer (Non Access Stratum Layer) is also not required as we are not considering the ProSe server and EPC as entities in our experiment. Hence we do not require PC3 and PC4 Interfaces for our D2D communication[1-4]. The Protocol stack for our Experiment is depicted in Fig.5.

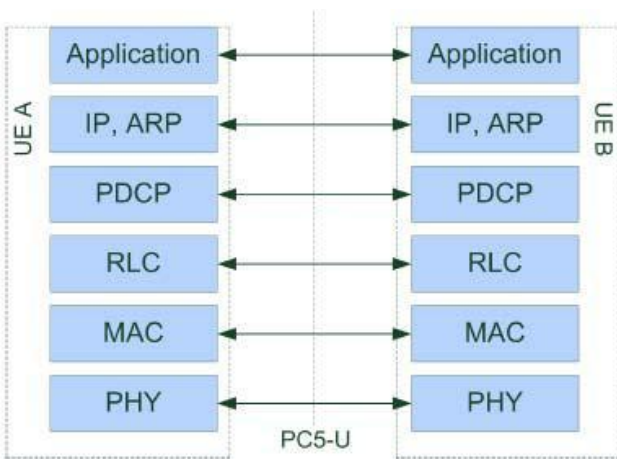

Fig.5-Protocol Stack for D2D Communication

Let us now list the Layers with the functions carried out by them

- 1) Physical Layer: Air Interface Communication
- 2) MAC layer: Scheduling of Transport Block
- 3) RLC layer: Segmentation and Reassembly
- 4) PDCP Layer: Header Compression and Ciphering
- 5) IP/ARP Layer: Networking
- 6) Application Layer: Application to be developed accordingly

In our Experimentation we are considering these 6 Layer for each UE to find a Networking path and Transfer an Image.

TTT-SIMULA nON RESULTS

We had implemented the 3GPP test Specification according to Release 2014 and Release 2105 in Matlab, wherein we are able to Transfer the Image from one node to another.

Here we need to write the IP address and Port Number in the sender Node. Then it will pick up the Node tracing all the 6 layers mentioned and Image is displayed at the receiver node using D2D communication under simulation. Fig.6 show the simulation Result conducted using matlab to implement D2D communication using PC5 Interface.

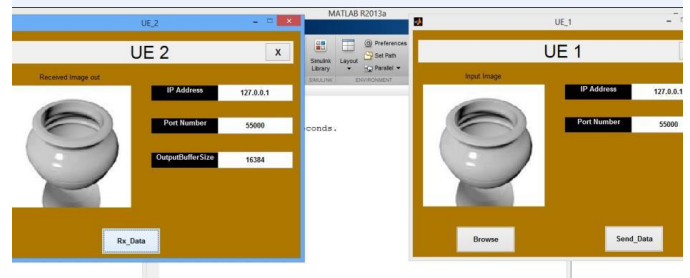

Fig.6-Simulation Results for Image Transfer

Since we have implemented this scenario using IPv6 Networking Protocol the routing Protocol used must be either of three mentioned below:

- 1) RIPng. RIPng stands for Routing Information Protocol Next Generation.
- 2) OSPFv3. Stands for Open Shortest Path First version 3
- 3) BGPv4. BGP stands for Border Gateway Protocol. It is the only open standard Exterior Gateway Protocol available.

IV LIMITATIONS OF EXPERIMENT

Since we are using the 6 Layer Protocol Stack Structure which is having IP Layer as Networking Layer. The Routing in IP Layer is done by RIPng, OSPFv3 and BGPv4 routing Protocols. None of the protocols are for MANETs. MANETs is a Scenario where in the Nodes are distributed without Network and Routing is done by MANET Routing Protocols like DSDR, AODV etc.

In the Experiment the automatic route formation for MANETs using Routing Protocols for MANETs is missing. Thus the scenario doesnot completely Matches with MANETs scenario with Nodes connecting and discovering one another using MANET Routing Protocol. Thus this should be carried out in Future enhancement of Project work.

V FUTURE ENHANCEMENT OF PROJECT

Here as mentioned in previous section, The experiment should be carried out without using the routing Protocol RIPng,OSPFv3 and BGPv4. Instead of that The Project should be implemented with AODV as Routing Protocol with IPv6 as IP address. The Fig7. Show the Startery of Project underway for the experimentation of Image Transport Protocol in MANETs using 5G's D2D technology.

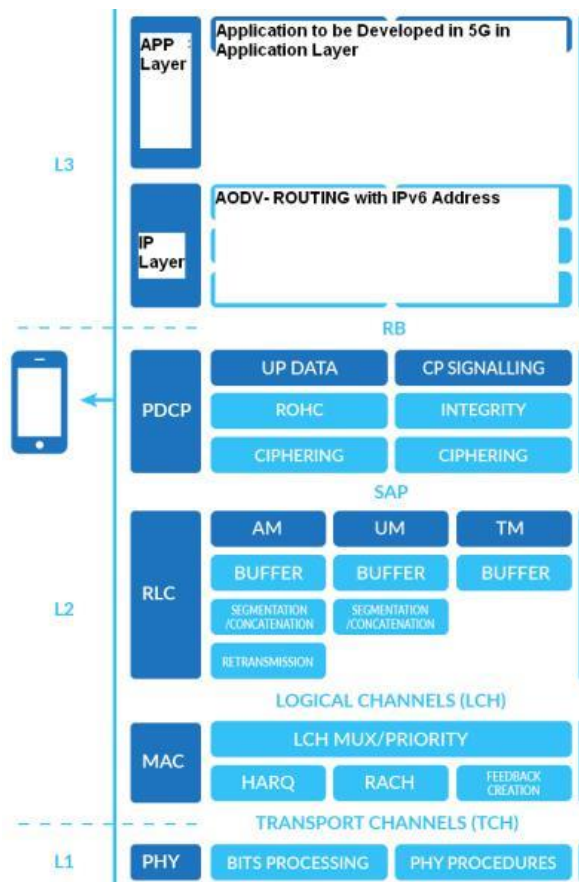

Fig.7-Stack Layer for Implementation of Image Transport in MANETs.

VI CONCLUSION

In this Paper we demonstrated to carry out the Image Transfer using D2D communication with Direct ProSe discovery and Direct ProSe communication using PC5 interface as mentioned in 3GPP Test Specifications in Release 2014 and Release 2015. After the results got with this scenario we are going implement this with changes in existing Routing Mechanism with that of MANET Routing of AODV.

ACKNOWLEDGEMENT

We are very Thankful to Dayananda Sgar College of Engineering for Providing Infrastructure to utilize for Research experimentation. We are very much help by the white paper of Rohde and Schwarz Company in D2D communication, which we regards as base paper for our Research. We are Thankful to Dr.Sayed Abdulhayan, research Associate Professor,Dayananda Sagar College of Engineering for his contribution toward experiment the scenario according to 3GPP test specifications. We are thankful to Mr.Samiullah for assistance in Matlab Code development.

REFERENCES

[1]3gpp ts 22.468 v12.1.0, September 2014; technical specification group services and system aspects; group communication system enablers for lte
 [2]3gpp ts 23.468 v12.5.0,june 2015; technical specification group services and system aspects; group communication system enablers for lte
 [3]3gpp ts 23.303 v12.5.0,june 2015; technical ts specification group services and system aspects; proximity-based services
 [4]Device to Device communication in LTE,IMA264.White Paper, Rohde & Schwarz GmbH & Co. KG MiihldorfstraBe 15 ,D - 81671 Miinchen,2015

Source Code-Multicell scenario

```
clc;
close all;
clear all;
%Hexagon parameters
for rty=1:400
    filename=['run15_',num2str(rty),'.mat']
    R=1000;
    len=3000;
    wid=3000;
    CUE=1; % no of CUE devices
    D2D=randi([3 15],1);% no of D2D devices
    L0=30.18; %fixed Propagation Loss
    sigma_shadowing=4;
    gamma=2.6;
    n=D2D/2;
    active_dist1=0;
    active_dist2=0;
    active_pair1=0;
    active_pair2=0;
    active_hybrid1=0;
    active_hybrid2=0;
    Genode=48; %dBm
    %Drawing the Hexagon
    nx1=len/(2*R);
    nx=round(nx1); % x size
    ny1=wid/(2*R);
    ny=round(ny1); % y size
    % one hexagon coordinaties:
    al=0:((2*pi)/6):2*pi;
    xh=R*cos(al);
    yh=R*sin(al);
    xcell=[];
    ycell=[];

    hold on;

    % first rectangular spaced hexagons set
    x0=R;
    y0=sqrt(3)*R/2;
    x=x0;
    y=y0;
    j=5;%cell numbering
    for nxc=1:nx
        for nyc=1:ny
            plot(x+xh,y+yh,'b');
            plot(x,y,'k^');
            xcell=[xcell x];%recording cell coordinatues
            ycell=[ycell y];
            j=j+1;
            y=y+sqrt(3)*R;
        end
        x=x+3*R;
        y=y0;
    end
end
```

```

end

% second rectangular spaced hexagons set
x0=2.5*R;
y0=sqrt(3)*R;
x=x0;
y=y0;
for nxc=1:(floor(nx/1))
    for nyc=1:(floor(ny/1))
        plot(x+xh,y+yh,'r');
        plot(x,y,'k^');
        xcell=[xcell x];%recording cell coordinates
        ycell=[ycell y];
        j=0;

        % numberofcells=j

        y=y+sqrt(3)*R;
    end
    x=x+3*R;
    y=y0;
end

axis equal;
axis([0 len 0 wid]);
grid;
%End of the hexagon code
%Generating the users randomly and uniformly

xuser=rand(1,CUE).*len; % 100>>> akbar coordinate momken el-user ya5do, 1*un da 3adad el-random
coordinates el-users haia5dohom
yuser=rand(1,CUE).*wid;
D2Dxuser=rand(1,D2D).*len;
D2Dyuser=rand(1,D2D).*wid;
scatter(D2Dxuser,D2Dyuser,'red')
scatter(xuser,yuser,'blue','filled')
for i=1:1:CUE
    text(xuser(i)+0.05,yuser(i)+0.05,num2str(i)); %giving each user a number on the graph
end
for i=1:1:D2D
    text(D2Dxuser(i)+0.05,D2Dyuser(i)+0.05,num2str(i)); %giving each of D2D user a number on the
graph
end
%End of generating the users Code
%Calculating the distance between each user and each BTs

for j=1:1:length(xuser)
    dist(j,:)=sqrt((D2Dxuser-xuser(j)).^2 + (D2Dyuser-yuser(j)).^2);
end

for j=1:1:length(D2Dxuser)
    for i=1:1:length(D2Dyuser)

```

```

masafa(j,:)=sqrt((D2Dxuser(j)-xuser).^2 + (D2Dyuser(i)-yuser).^2);
    end
    distx=masafa';
end
for j=1:1:length(D2Dxuser)

masafa1(j,:)=sqrt((D2Dxuser(j)-D2Dxuser).^2 + (D2Dyuser(j)-D2Dyuser).^2);
    end
    distD2Dx=masafa1';
    for j=1:1:length(xuser)
        masafa2(j,:)=sqrt((xuser(j)-xuser).^2 + (yuser(j)-yuser).^2);
    end
    distCUEx=masafa2';
    distD2D=masafa1./1000;
    dist=masafa./1000;
    distCUE=masafa2./1000;
    %End of calculating the dist
    %Generating power,Gain,AWGN for each device

GTxmin=20;
GTxmax=25;
for i=1:1:D2D
    for j=1:1:D2D
        if i~=j
            GTx(i,j)=randi([20 25]);
        end
    end
end
GRxmin=20;
GRxmax=25;
for i=1:1:D2D
    for j=1:1:D2D
        if i~=j
            GRx(i,j)=randi([20 25]);
        end
    end
end
PTxmin=20;
PTxmax=25;
for i=1:1:D2D
    for j=1:1:D2D
        if i~=j
            PTx(i,j)=randi([20 25]);
        end
    end
end
for i=1:1:D2D
    for j=1:1:D2D
        if i~=j
            AWGN(i,j)=randi([1 3]);
        end
    end
end
% getting minimum distance
K=min(distD2D(distD2D>0));

```

```

[Atten]=prop_channel(L0, gamma,distD2D, sigma_shadowing);
for i=1:1:D2D
    for j=1:1:D2D
        Atten(i,j)=Atten(j,i);
    end
end

for i=1:1:D2D
    for j=1:1:D2D
        if i==j
            x(i,j)=0
            S(i,j)=0
        else
            x(i,j) =PTx(i,j)+GTx(i,j)+GRx(i,j)-Atten(i,j); %Main Signal
            S(i,j) = PTx(i,j)+GTx(i,j)+GRx(i,j)-Atten(i,j); % interference
        end
    end
end

for i=1:1:D2D
    for j=1:1:D2D
        interf(i,j)=0;
        if i~=j
            for m=1:1:D2D
                if m~=j&& m~=i %main condition to calculate interference

                    interfx(i,j)=interf(i,j)+10^(S(m,j)/10);%total interference
                end

            end
            interf(i,j)=interfx(i,j)+10^(AWGN(i,j)/10);
        end
    end
end

for i=1:1:D2D
    for j=1:1:D2D
        if i==j
            x(i,j)=0
            S(i,j)=0
        else

            sinr(i,j) = 10.^(x(i,j)/10)/interf(i,j);
        end
    end
end

sinr=10*log10(sinr); %dB
sinr( sinr== -inf )=0;
% number of pairs
pairsnum=0;
tmp3=sinr;
tmp3( tmp3<0 )=-inf;
for i=1:1:D2D
    for j=1:1:D2D

```



```

    if tmp3(i,j)>0 && tmp3(j,i)>0

        pairsnum=pairsnum+1;
        tmp3(i,j)=0;
        tmp3(:,i)=0;
        tmp3(j,:)=0;
    end

end

end

% best D2D pairs:
% here we choose best SINR in the two directions
tmp1 = sinr;
mincom=0;
for i=1:1:length(sinr);
    for j=1:1:length(sinr)
        if tmp1(i,j)>0 && tmp1(j,i)>0
            if tmp1(i,j)<=tmp1(j,i)
                mincom(i,j)=tmp1(i,j);
            else if tmp1(i,j)>=tmp1(j,i)
                mincom(i,j)=tmp1(j,i);
            end
        end
    end
end
end
end
active_pair1 = max (max(mincom));
for i=1:1:length(sinr);
    for j=1:1:length(sinr)
        if tmp1(i,j)== active_pair1
            active_pair2=tmp1(j,i);
        end
    end
end
end

outage_sinrx=(floor(n)-pairsnum)/floor(n);
outage_sinr=outage_sinrx*100;
% best D2D pair according to shortest distance
countdist=0;
tmp = distD2D;
tmp(tmp==0) = Inf;
c = min(tmp,[],D2D);
[num idx] = min(c(:));
[q p] = ind2sub(size(c),idx);
if sinr(q,p)>0 && sinr(p,q)>0
    active_dist1=sinr(q,p);
    active_dist2=sinr(p,q);
    countdist=countdist+1;
    outagedistx=(floor(n)-countdist)/floor(n)
    outagedist= outagedistx*100
else
    outagedist=100 % probability of finding active pair with respect to minimum distance
end

```

```

end
%hybrid optimum sinr and distance threshold 500 m
counthybridx=0;
counthybridx1=0;
counthybridx2=0;
counthybridx3=0;
counthybridx4=0;
counthybridx5=0;
hypmincom=0;
hypmincom1=0;
hypmincom2=0;
hypmincom3=0;
hypmincom4=0;
hypmincom5=0;
tmp4=sinr;
tmp11=sinr;
for i=1:1:length(sinr);
    for j=1:1:length(sinr)
        if distD2D(i,j)<0.5 && distD2D(j,i)<0.5
            if tmp11(i,j)>0 && tmp11(j,i)>0
                counthybridx=counthybridx+1;
                tmp11(i,j)=0;
                tmp11(:,i)=0;
                tmp11(j,:)=0;
            end
            if tmp4(i,j)>0 && tmp4(j,i)>0
                if tmp4(i,j)<=tmp4(j,i)
                    hypmincom(i,j)=tmp4(i,j);
                else if tmp4(i,j)>=tmp4(j,i)
                    hypmincom(i,j)=tmp4(j,i);
                end
            end
        end
    end
end
end
end
end
end

active_hybridx51=max(max(hypmincom));
for i=1:1:length(sinr);
    for j=1:1:length(sinr)
        if tmp4(i,j)== active_hybridx51
            active_hybridx52=tmp4(j,i);
        end
    end
end
end

outage_hybridx=(floor(n)-counthybridx)/floor(n);
outage_hybrid=abs(outage_hybridx*100);

outage_hybridx5=(floor(n)-counthybridx)/floor(n);
outage_hybrid5=abs(outage_hybridx5*100);
%hybrid optimum sinr and distance threshold 100 m
tmp7=sinr;
tmp12=sinr;
for i=1:1:length(sinr);

```

```

for j=1:1:length(sinr)
    if distD2D(i,j)<0.1 && distD2D(j,i)<0.1
        if tmp12(i,j)>0 && tmp12(j,i)>0
            counthybridx1=counthybridx1+1;
            tmp12(i,j)=0;
            tmp12(:,i)=0;
            tmp12(j,:)=0;
        end
        if tmp7(i,j)>0 && tmp7(j,i)>0
            if tmp7(i,j)<=tmp7(j,i)
                hypmincom1(i,j)=tmp7(i,j);
            else if tmp7(i,j)>=tmp7(j,i)
                hypmincom1(i,j)=tmp7(j,i);
            end
        end
    end
end
end
end

active_hybridx11=max(max(hypmincom1));
for i=1:1:length(sinr);
    for j=1:1:length(sinr)
        if tmp7(i,j)== active_hybridx11
            active_hybridx12=tmp7(j,i);
        end
    end
end

outage_hybridx1=(floor(n)-counthybridx1)/floor(n);
outage_hybrid1=abs(outage_hybridx1*100);

%hybrid optimum sinr and distance threshold 200 m
tmp8=sinr;
tmp13=sinr;
for i=1:1:length(sinr);
    for j=1:1:length(sinr)
        if distD2D(i,j)<0.2 && distD2D(j,i)<0.2
            if tmp13(i,j)>0 && tmp13(j,i)>0
                counthybridx2=counthybridx2+1;
                tmp13(i,j)=0;
                tmp13(:,i)=0;
                tmp13(j,:)=0;
            end
            if tmp8(i,j)>0 && tmp8(j,i)>0
                if tmp8(i,j)<=tmp8(j,i)
                    hypmincom2(i,j)=tmp8(i,j);
                else if tmp8(i,j)>=tmp8(j,i)
                    hypmincom2(i,j)=tmp8(j,i);
                end
            end
        end
    end
end
end
end
end

```

```

active_hybridx21=max(max(hypmincom2));
for i=1:1:length(sinr);
    for j=1:1:length(sinr)
        if tmp8(i,j)== active_hybridx21
            active_hybridx22=tmp8(j,i);
        end
    end
end
end

```

```

outage_hybridx2=(floor(n)-counthybridx2)/floor(n);
outage_hybrid2=abs(outage_hybridx1*100);
%hybrid optimum sinr and distance threshold 300 m
tmp9=sinr;
tmp14=sinr;
for i=1:1:length(sinr);
    for j=1:1:length(sinr)
        if distD2D(i,j)<0.3 && distD2D(j,i)<0.3
            if tmp14(i,j)>0 && tmp14(j,i)>0
                counthybridx3=counthybridx3+1;
                tmp14(i,j)=0;
                tmp14(:,i)=0;
                tmp14(j,:)=0;
            end
            if tmp9(i,j)>0 && tmp9(j,i)>0
                if tmp9(i,j)<=tmp9(j,i)
                    hypmincom3(i,j)=tmp9(i,j);
                else if tmp9(i,j)>=tmp9(j,i)
                    hypmincom3(i,j)=tmp9(j,i);
                end
            end
        end
    end
end
end
end
end
end

```

```

active_hybridx31=max(max(hypmincom3));
for i=1:1:length(sinr);
    for j=1:1:length(sinr)
        if tmp8(i,j)== active_hybridx31
            active_hybridx32=tmp9(j,i);
        end
    end
end
end

```

```

outage_hybridx3=(floor(n)-counthybridx3)/floor(n);
outage_hybrid3=abs(outage_hybridx3*100);

%hybrid optimum sinr and distance threshold 400 m
tmp10=sinr;
tmp15=sinr;
for i=1:1:length(sinr);
    for j=1:1:length(sinr)
        if distD2D(i,j)<0.4 && distD2D(j,i)<0.4
            if tmp15(i,j)>0 && tmp15(j,i)>0

```

```

        counthybridx4=counthybridx4+1;
        tmp15(i,j)=0;
        tmp15(:,i)=0;
        tmp15(j,:)=0;
    end
    if tmp10(i,j)>0 && tmp10(j,i)>0
        if tmp10(i,j)<=tmp10(j,i)
            hypmincom4(i,j)=tmp10(i,j);
        else if tmp10(i,j)>=tmp10(j,i)
            hypmincom4(i,j)=tmp10(j,i);
        end
    end
end
end
end
end
end

active_hybridx41=max(max(hypmincom4));
for i=1:1:length(sinr);
    for j=1:1:length(sinr)
        if tmp10(i,j)== active_hybridx41
            active_hybridx42=tmp10(j,i);
        end
    end
end
end

outage_hybridx4=(floor(n)-counthybridx4)/floor(n);
outage_hybrid4=abs(outage_hybridx4*100);
save(filename);
clear all;
close all;
clc;
end

```