

THESIS ON MECHANICAL ENGINEERING E108

Energy Efficiency Evaluation Method for Mobile Robot Platform Design

EERO VÄLJAOTS

TUT
PRESS

TALLINN UNIVERSITY OF TECHNOLOGY
School of Engineering
Department of Mechanical and Industrial Engineering

Dissertation was accepted for the defence of the degree of Doctor of Philosophy in Engineering on 23 February, 2017.

Supervisors: Senior Researcher Raivo Sell, PhD, Department of Mechanical and Industrial Engineering, Tallinn University of Technology

Professor Emeritus D.Sc.Eng Rein Laaneots, Department of Electrical Power Engineering and Mechatronics, Tallinn University of Technology

Opponents: Professor Dr.Sc.Ing Agris Nikitenko, Department of Artificial Intelligence and Systems Engineering, Riga Technical University, Latvia

Andres Petritšenko, PhD, Project Leader at Teamwork Engineering OÜ

Defence of the thesis: 30 March, 2017

Declaration:

Hereby I declare that this doctoral thesis, my original investigation and achievement, submitted for the doctoral degree at Tallinn University of Technology has not been submitted for doctoral or equivalent academic degree.

/Eero Väljaots/

Copyright: Eero Väljaots, 2017
ISSN 1406-4758
ISBN 978-9949-83-085-5 (publication)
ISBN 978-9949-83-086-2 (PDF)

MEHCHANOTEHNIKA E108

Liikuva robotplatvormi energia efektiivsuse hindamise meetod

EERO VÄLJAOTS

CONTENTS

INTRODUCTION	7
ABBREVIATIONS AND SYMBOLS	9
1. LITERATURE REVIEW	12
1.1 Unmanned ground vehicles.....	12
1.2 Design process of robotic systems.....	14
1.3 UGV performance evaluation	18
1.4 Main objectives.....	21
2. REQUIREMENTS FOR PRODUCT DESIGN	22
2.1 Requirements and key parameters for mobile platform design.....	22
2.2 Typical mobile robot platform design types	26
2.3 Conclusions of requirements for product design	30
3. EFFICIENCY METRICS	31
3.1 Energy consumption model	31
3.2 Evaluation of resistive forces.....	33
3.3 Energy efficiency measures	37
3.4 Operational efficiency measures.....	41
3.5 Uncertainty in the measurement system	42
3.6 Conclusions of efficiency metrics.....	45
4. EFFICIENCY PROFILES AND DESIGN METHODOLOGY.....	46
4.1 Design methodology	46
4.2 Energy efficiency profiles of a platform.....	48
4.3 Methodology framework.....	51
4.4 Conclusions of efficiency profiles and design methodology	52
5. EFFICIENCY VALIDATION AND TEST MISSIONS.....	53
5.1 Test platforms	53
5.2 Test missions.....	58
5.3 Validation testing.....	62
5.4 Compilation of efficiency profiles	70
5.5 Validation results	74
5.6 Conclusions of efficiency validation and test missions	75
CONCLUSIONS	76

REFERENCES	80
ABSTRACT	85
KOKKUVÕTE	87
LIST OF PUBLICATIONS	89
ELULOOKIRJELDUS	90
CURRICULUM VITAE.....	91

INTRODUCTION

Background

Autonomous vehicle market is growing rapidly. After the market expansion of the ongoing unmanned aerial vehicle (UAV), the unmanned ground vehicles (UGV) are expected to gain similar exponential growth of interest. The global UGV market is projected to grow nearly three times by 2020 compared with current size [1, 2]. Besides the initial military field of uses, unmanned ground vehicles are gaining rising interest in consumer market for different civil tasks. Various UGV concepts are extensively developed and used for civil application [3 – 6]. While automation and robotics technology becomes available with lower expenses, the development complexity increases and lead time to market is shrinking. As only the thoroughly studied and fine-tuned platforms are competitive, considerable effort is required to tune the performance and efficiency to customer expectation level.

Decisions in an early development phase are especially important as they define the following design process and have high impact on the overall success of a final product [7]. Designing an autonomous robot is not a trivial task and a designer must consider many limits and opposing requirements. To acquire valuable feedback about design choices, prototyping and testing must be used, although it is expensive and time consuming for complex mechatronic system-of-systems. Therefore, appropriate tools and methods are needed for designers to find out an optimal solution in minimum time.

Vehicle mobility relies on limited energy resources, which creates a need to maximize energy efficiency. All inefficiencies in platform design, operation, reliability and safety translate to loss of energy and degrade emission indicators. Inefficiencies raise the platform exploitation costs and lower its competitiveness on market. Consumer is usually interested in buying the product most suitable for his needs and is willing to have objective information with minimum effort about the solutions and their performance. Validated knowledge base to predict performance and suitability would allow easy comparison of different platform designs.

Analysis and estimation of efficiency parameters are not a straightforward procedure, as they are often contradictive and depend considerably on the design and environment parameters. In addition, there might be strict requirements for mass, dimensions or visual appearance that degrade operational and energy efficiency. As UGVs are often used in the conditions dangerous for humans, durability of their design is the main demand. However, if the vehicle is overweighted and strength reserves exaggerated, it is easily conflicting to energy efficiency. While planning mission scenarios for UGVs, energy requirement predictions that uses platform and mission measurable parameters and prior knowledge are very important [8].

Motivation and problem definition

Vehicle energy consumption is one of the most important parameters on the consumer market and the competition demands that it could be minimized whenever possible. However, standardized energy efficiency evaluation of different unmanned applications and corresponding designs is uncommon [9]. Comparison of two competitive mobile platforms requires time-consuming testing and data analysis to map their design key-parameters and advantages. Therefore, standardized performance evaluation and resulting knowledge library can help to speed up new concept generation and lead to fine tuning and detailing phase much quicker.

The aim of this research is to improve the UGV early design phase with a focus on the energy efficiency. Designing a complex mechatronic system is a time-consuming task with expensive prototype building and thorough trial-error testing. As a result of provision of a validated model knowledge library, efforts can be considerably reduced to reach an optimal and energy efficient solution. Therefore, there is a great need for a practical usable system that enables compiling of energy efficiency profiles of different robot platforms and indicates their suitability for planned tasks and missions. Furthermore, expected platform qualities for successful operation can be predicted.

As the mobile platforms and their tasks are complex, the efficiency cannot be described with one parameter, rather it needs a set of key-parameters and parameter relations corresponding to the task. The first objective is to determine efficiency descriptors to the tasks and classify them. Study of different tasks involves also finding the priorities to descriptors and rating them. Usually UGVs are designed more or less universal to complete missions that consist of several tasks which are mostly different. There might be tasks that can successfully be accomplished by almost any platform or in contrast, tasks that set very high requirements to platforms. Mission profiles can be combined from single task profiles which should also have priorities assigned. This enables us to create requirement profiles for tasks and missions for defining the key-parameters. The key-parameter relations, dependencies and test layout planning are modelled by System Modelling Language (SysML) [10, 11].

The next objective is to validate the UGV efficiency for given tasks and the mission. As the UGV performs in interaction with the environment and terrain to process the task, this interaction can be measured directly in a real-condition test. While required key-parameters are defined based on task profiles, the appropriate measurement system should be composed for capturing the dynamic data during validation tests. It is also important to take into account uncertainty of the input measures for result quality assessment. Using the recorded UGV performance data, energy efficiency profiles to platforms should be composed. Comparison of task and UGV profiles indicates the UGV efficiency and derives the recommendations for design improvements. These valuable results are stored in a database and can be used for validating simulations and predicting the efficiency of future design concepts.

ABBREVIATIONS AND SYMBOLS

ADC	Analog to Digital Converter
AWD	All Wheel Drive
ATV	All Terrain Vehicle
BLDC	BrushLess Direct Current
CAD	Computer Aided Design
CAN	Controller Area Network
DC	Direct Current
GPS	Global Positioning System
ICE	Internal Combustion Engine
INS	Inertial Navigation System
MEMS	MicroElectroMechanical System
MTBF	Mean Time Between Failures
RWD	Rear Wheel Drive
SME	Small and Medium Enterprises
SysML	System Modelling Language
UAV	Unmanned Aerial Vehicle
UGV	Unmanned Ground Vehicle
UTC	Universal Time Coordinated
VMS	Vehicle Management System
XML	Extensible Markup Language

n_r	reliability ratio
a	vehicle longitudinal acceleration
a_{lim}	vehicle acceleration limit
a_{max}	vehicle maximum measured acceleration
A_c	platform coverable area
A_d	cross-section area of the vehicle body
A_o	area under obstacles
C_i	vehicle internal resistance
C_d	aerodynamic drag coefficient
C_f	energy conversion coefficient
C_r	rolling resistance coefficient
C_{trad}	cost of traditional solution
C_{ugv}	cost of autonomous platform
E	energy
E_{in}	input energy
E_{out}	output energy
F_a	vehicle acceleration
F_d	vehicle bodywork aerodynamic drag
F_g	track gradient
F_n	summary resistive force
F_t	working operation resistance

F_p	drawbar pull force
F_r	wheel rolling resistance
g	acceleration due to gravity
I	current
I_{max}	maximum allowed current
k	trajectory curvature index
m	vehicle mass
n	count
P_d	drawbar pulling power
P_e	power required from vehicle electronic equipment
P_p	power of an engine/motor
Q	fluid flow
R_e	earth radius
R_n	trajectory segment curve radius
s	vehicle travelled distance
s_e	distance measured with wheel encoder
s_i	ideal route length
s_r	actual route length
s_o	distance to obstacle
t	operating time
t_{fp}	time while having full performance
t_{rp}	time while having reduced performance
t_c	time to collision
t_o	operator spent time
t_r	platform operation time
U	battery voltage
u	standard deviation
v	vehicle speed
v_a	air relative velocity (wind)
X	latitude GPS coordinate
x	correction
Y	longitude GPS coordinate
α	track gradient angle
δ_b	axis bias correction
δ_g	natural acceleration change correction
δ_{nl}	axis scale factor correction
δ_{res}	analog to digital converter sensitivity correction
δ_{sc}	axis scale factor correction
δ_{temp}	environment temperature correction
δ_{wn}	white noise correction
ε	general systematic error effect
ε_B	bias systematic effect
ε_B	position systematic effect

Δ	single measure
η	efficiency ratio
η_{Σ}	total energy efficiency ratio
η_a	autonomy ratio
η_e	energy efficiency ratio
η_L	load ratio
η_n	navigation efficiency ratio
η_s	safety ratio
η_t	traction efficiency ratio
ρ_a	air density
σ	standard deviation

1. LITERATURE REVIEW

1.1 Unmanned ground vehicles

UGV is a ground contact vehicle that operates without on-board human operator. The UGVs are used in many applications where the presence of human operator is too dangerous, inconvenient or impossible. It is perfect for boring, monotonous and repeated accuracy critical tasks. Compared with UAV systems, navigating on ground is much more difficult than in air. Nevertheless, by using latest technology, autonomous vehicles are expected soon to overcome restrictions of environment conditions and outperform human operators [12].

The UGV platforms use a set of sensors to measure and observe surrounding environment, pass the information and make decisions about its behaviour either autonomously or they are controlled through teleoperation by human in different locations. An easier way of UGV development consists in converting a regular vehicle's (car, tractor, ATV etc.) accelerating, steering, braking controls into electronically operated actuators. However, a vehicle built for accommodating a human operator is usually not space and shape efficient in comparison with a platform built unmanned from scratch. In addition to handling actuators, every UGV platform includes the global positioning system (GPS) compounded with an inertial navigation system (INS) for positioning and proximity sensors (mechanical, subsonic or laser based) for obstacle detection. Nowadays every competitive platform includes image processing capabilities for a higher level of navigation decisions by using stereo camera systems to acquire accurate range images.

Considering the active UGV development projects of robotics companies [13] and their applications, universal mid-size UGVs are desired to replace humans on easy handled tasks. Although there is great interest and support for such UGV development projects for military applications [14] (Fig. 1.1a), a rapidly increasing number of professional platform designs are targeted to civil market [15 – 18] (Fig. 1.1b). In both fields of application, the operational and energy efficiency is the key for marketing success.

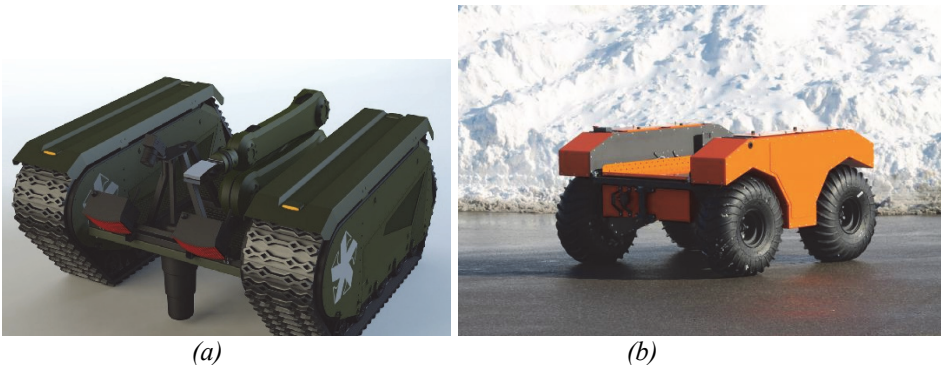

Figure 1.1 Examples of UGV platforms: a – military, Milrem; b – civil, Argo amphibious UTV.

Mobile platforms have a broad field of applications, either teleoperated or autonomous mode. As technology evolves, teleoperation is expected to be gradually replaced with autonomous operation where UGV obtains more control over its behaviour. Then, instead of a human, the operational efficiency depends on the adaptation capabilities of robot algorithms. Suitable missions for reliable autonomous operation today would include mostly drive to position, repetitive and simple tasks.

Possibly one of the most important needs to use UGV is danger to human lives. An example here is a UGV task for bomb disposal [19] (Fig. 1.2) where a robot is usually teleoperated from distance. An example of an autonomous UGV mission in the same field is:

- search for explosives in a defined area;
- attempt to dispose when a recognized object is found, or
- transport of the object to a safe position for exploding.



Figure 1.2 Talon bomb disposal robot [19].

Naturally, tasks of surveillance and reconnaissance can be completed more efficiently by UAV or stationary electronics. Nevertheless, there are many mission examples for civil universal UGV platforms that are operating fully autonomously and are equipped with special tools:

- snow plowing car lots;
- non-stop soil sampling on large agricultural fields;
- non-chemical pest control in organic farming;
- nuclear and toxic waste handling and recycling;
- feed transportation to livestock in farms.

Although UGV capabilities are underexploited mainly because of the complex navigation technology, predictions are optimistic since there are many applications where UGV is irreplaceable.

1.2 Design process of robotic systems

Design process of an efficiently operating UGV is similar to any other high level mechatronics system development process. It goes through several steps from requirements to the final product [20, 21]. Between the requirements and deployment, several actions are cycled:

- modelling,
- simulation,
- prototyping.

As this is a sequential process, later levels depend on the previous ones. The V-model [20] (Fig. 1.3) organizes these actions into a macro-cycle adopted from software development and adapted to the requirements of mechatronics. During the system design, it is broken down into sub-functions and solutions assigned. Concurrent domain-specific design specifies all solutions separately. System integration forms the system from individual domains to study their interaction. All phases are aided by model analysis tools and simulations.

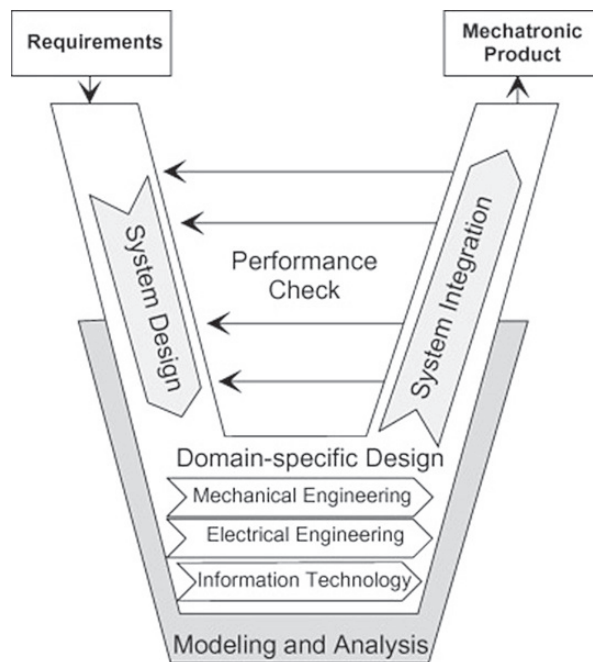

Figure 1.3 Model based mechatronic system design V-cycle [20].

To assure that actual system properties coincide with desired system properties, a prototype is used for verification and validation. The verification and the validation are differentiated as follows:

- verification checks whether the results coincide with the specification;
- validation tests whether the result achieves the desired value.

With more complex systems developed, several cycles are used and prototypes built. At least in the case of UGVs, prototype building and testing is usually very expensive and time consuming since rapid prototyping methods help the process only slightly.

Clearly, the conceptual design stage has the strongest impact on the whole product and its lifecycle. A poorly planned concept cannot be compensated with good technical detailing. As the design space is extremely wide even for a simple function like motion, the designer's work is very labour consuming. Main selection must be made in the conceptual design stage – the design decision locks many further parameters like cost, production time, maintainability and even marketing strategies. Here the conceptual design support methodology can be of considerable help in an effective and qualitative design process in the early design stage.

Modern mechatronic power generating machine, like a mobile robotic platform, can be characterized by a continuous or periodic energy and information flow [22]. A primary energy that flows into the machine is either directly consumed in the case of an energy transformer, or converted into another energy form in the case of an energy converter (Fig. 1.4). In contrast to basic mechanical systems, one characteristic of many mechatronic systems is the addition and integration of feedback information flow to a feedforward energy flow. During the operation, information in the mechatronic system is processed based on measured variables and decisions made to manipulated variables that alter the further operation. As can be seen, the efficiency of the energy and information flow defines the platform performance capability.

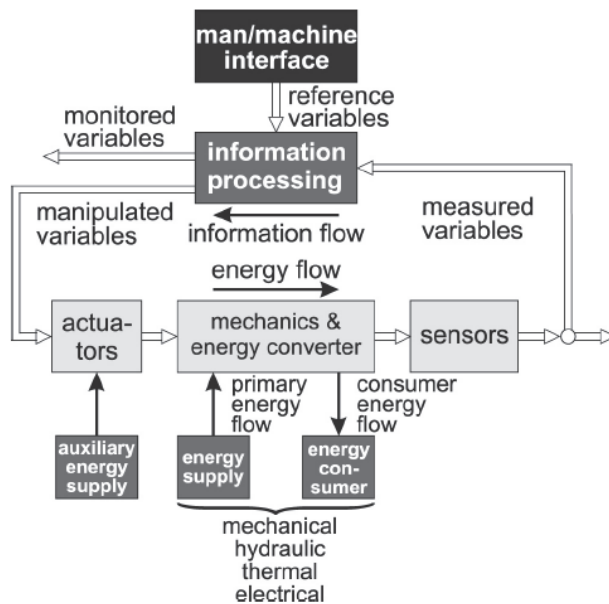

Figure 1.4 Energy and information processing in mechatronic systems [22].

Excluding pure transportation purposes [17], most UGV platforms under development are designed more or less universal, capable of executing several different tasks when equipped with special tools. Typical subsystems of a mobile robotic platform are:

- locomotion;
- energy management;
- positioning and sensor management;
- communication;
- safety;
- tool (if needed).

Universal capability requires several compromises to be made on the design. To overcome the problem, several recent platforms are designed modular [14, 18] to widen the field of applications, reduce the manufacturing costs, add versatility and reconfigurability. Then the design consists of modular subsystems, which can be compounded into a platform according to the requirement of the application.

As mobile robotics is an untraditional, innovative and technologically advanced sector of machine engineering, initiatives are on small and medium enterprises (SMEs) whose purpose is to start their own products on rapidly growing market. Although flexible to develop custom designs, large companies have more resources for development. It is evident that a system with more autonomy must at the same time be technically more sophisticated. The development cycle is a very resource demanding process if the company is lacking previous knowledge. To create better products cost-efficiently, the barrier of technology for SMEs could be lowered in different ways. While managing design complexity with a modular structure, sharing knowledge on open-platforms and re-using existing designs and engineering data offers clear advantages for SMEs.

Early design process and supporting engineering toolbox can be visually modelled by SysML [10, 11]. A general purpose visual modelling language for systems engineering applications can help to deal with complex systems in a consistent way. It supports the specification, analysis, design, verification and validation of a broad range of systems by describing them with a set of diagrams. Other engineering analysis models are integrated by providing graphical representations with a semantic foundation for modelling system requirements, behaviour, structure, parametric etc. SysML advantages over its predecessor include more flexibility, extended capabilities, efficient requirement and functionality organization.

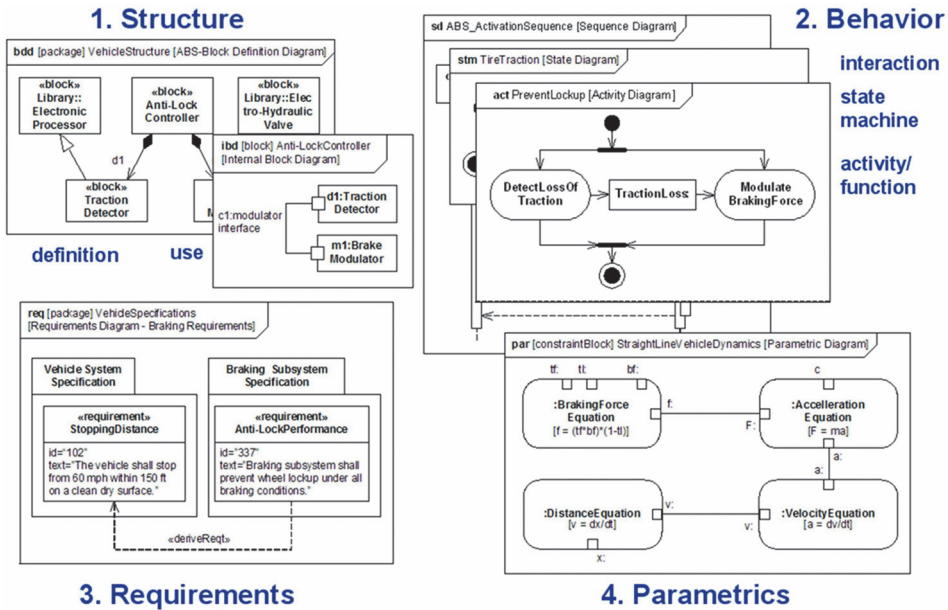

Figure 1.5 Four key diagram types of SysML [10].

Figure 1.5 summarizes the basic SysML diagram types that are used to represent the efficiency analysis throughout of the thesis. The *Block (bdd)* diagram represents the hardware, software or any other system elements by defining system hierarchy and classification. The *Package (pkg)* diagram is used to organize the model. The behaviour diagrams include *Use Case (uc)* diagram, *Activity (act)* diagram, *Sequence (sq)* diagram, and *State Machine (stm)* diagram. High-level description of functionality is provided by *Use Case* diagram obtained through interaction among system parts. The *Activity* diagram represents the flow of data and control between activities. A *Sequence* diagram represents the interaction between the collaborating parts of a system. The *State Machine* diagram describes the state transitions and actions that a system or its parts perform in response to events.

Usually, the requirements for a new product development are text based. The *Requirement (req)* diagram enables us to represent text based requirements and relates them with other models through derive, satisfy and verify relationships. The *parametric (par)* diagram manages system property constraints which enable integration of specifications with engineering analysis models. In addition to diagrams, relationships to represent various types of allocations are also included. While providing graphic tools and structures, SysML is perfect for describing complex mechatronic systems that tend to be systems-of-systems that do not fully integrate with each other.

1.3 UGV performance evaluation

The design of UGV moving abilities is based on the optimization of track and vehicle interaction for given conditions. Despite the moving method of a platform, it is most challenging to overcome obstacles in an autonomous mode. Optimization of rough terrain control for rovers has become an important and challenging research, especially in space programs where real condition failure leads to tremendous waste of time and money. Therefore, development of a new platform involves performance studies of previous solutions, as well as extensive testing [23].

In mobile robotics, standardized performance evaluation is uncommon [24]. Instead, every development company plans and performs independently evaluation process of product. As the degree of complexity in robotic systems is increasing, standardized performance evaluation is very important for design comparison and ensuring real-condition mission success. For example, there are several navigation methods for mobile robots and each time they are realized in a new software solution; some comparisons with previous efforts are usually made. Moreover, a set of generally accepted benchmarks would make algorithm performance evaluation much more efficient.

Most UGV performance evaluation programs include a comparison of basic task capabilities in simulated or artificial environments [25 – 27]. Typically, the results are obtained through scoring and judging, while the quality of metrics is limited to measuring the length of the robot path or time to complete a task. If scoring is appropriate in the development of simple manoeuvres and operations, still the degree and the way of improvement required is not indicated. Dynamic processes, like maintaining smooth efficient ride on autonomous navigation and obstacle avoidance, need quantitative methods [28]. Experimental studies of control algorithms for mobile robot navigation can be systematized using an appropriate test protocol and applying navigation comparison metrics, such as the trajectory (path) length, collision risk and smoothness of trajectory.

There are some indoor test-arenas in laboratories for developing standard test methods of measuring robot performance [29, 30] (Fig. 1.5). These specially built facilities house artificial landscapes, obstacles and other equipment to measure how well a robot performs under a variety of tasks that abstract real world challenges [31, 32]. Experiments are conducted by running a wide variety of robots through the prototype test methods to understand how to capture data best and to refine the physical artefacts and methodology. A variety of standard tests and specific test methods have been created. In addition, robot performance competitions are held [33] similar to Estonian Robotex. Still, few research institutions and companies can afford artificial test-arenas, others have to rely on real-condition testing. Besides, there is still a great need for a self-contained toolkit that can be used for unnoticeable, contemporary and simultaneous operational and energy efficiency analysis while the UGV is used in its planned field of application.



Figure 1.5 Indoor mobile robot test arena at NERVE Center [30].

Although there are many navigation methods, their efficiency and suitability for different conditions are often not compared. In the civil field of UGV applications, autonomous platforms for covering a closed area for vacuuming, painting, surface coating, lawn mowing are most common today. In such conditions, navigation algorithms performance can be assessed by measuring the percentage of covering by using computer vision techniques and wheel encoder measurements [34]. While covering an area using multiple robots [35, 36], effective algorithms have to be developed to minimize overlay and divide their operation areas. Objective comparison of competing platforms efficiency during the operation is still complicated.

It is especially important to measure performance in comparison to that of a human [37 – 40] in the development of autonomous intelligent systems for consumer market. In this case, the etalon during the performance benchmark is a human operator. Testing can be carried out in different ways:

- platform is teleoperated first by a human and later it operates autonomously, trying to reach or exceed human level;
- human and autonomous platform compete with each other while the progress is observed;
- human and autonomous platform complement each other trying to achieve better performance than separately possible.

Adaptive and learning robots are often working interactively with humans and communicating with an operator using speech and gestures. Efficiency of this communication directly determines the co-operation possibilities. For example, a wheeled UGV called "Workpartner" [41] is specially designed for tasks done usually by humans and equipped with manipulators similar to human arms. In the future, according to predictions, such helping robots will be in high demand in society when they become effective enough. In this case, energy efficiency analysis of a humanoid robot manipulator [42] is associated with the energy efficiency of a wheeled vehicle, which is partially similar.

Robot autonomy decreases with the increase of environment complexity. To quantify the environment complexity, many attempts have been made to compile an environment model [8, 43]. In order to create a grid, line or topological map about the testing environment, full information about conditions and obstacles are needed. As this is possible in a labour artificial environment, it is often not available for real-condition testing areas or available when UGV operates with the support of UAV [44]. Therefore, environment conditions have to be measured when possible during UGV interaction with it. Advanced range imaging algorithms enable creation of an environment map by the autonomous platform itself.

Although UGV energy efficiency is especially important on commercial products, research and experimental projects mostly leave it to background while concentrating on efficient navigation and terrainability. However, UGV optimal path planning with tradeoffs for energy and time has been studied [45, 46] to achieve best efficiency for area covering. Most mobile small and mid-size platforms use an electric motor and batteries for best energy transformation efficiency. Only platforms based on ordinary cars use ICE [47], which has clearly the worst conversion efficiency. Some military designation platforms [14, 48] use expensive hybrid power unit technology. Use of ICE is reasonable, for example, only when long time continuous operation of UGV is demanded and battery charging times prohibited. In all cases, the power unit type should be one variable in the energy efficiency analysis.

As wheel traction is an important parameter affecting directly wheeled vehicle energy efficiency, different ways of optimized rough-terrain controls are proposed. For example, wheel speed optimization is achieved using terrain profiling and wheel speed adjustment approach based on terrain shape estimation [49]. Another approach is to detect external forces resisting motion while analysing longitudinal acceleration data and to estimate wheel-ground contact angle for wheel torque optimization [50]. Instead of estimation, wheel-ground contact angles can be measured directly using embedded wheel sensors in tactile wheels. Based on this, the advanced torque control improves the rover terrainability by taking into account the whole mechanical structure [51]. All those methods improve performance by minimizing wheel slip on sandy surfaces and preventing the UGV being stuck. In fact, their efficiency can be practically compared using real condition measurements on the same track.

1.4 Main objectives

Based on the literature review, the main objectives of the thesis are:

- To analyse energy efficiency properties of tasks and missions assigned to mobile robotic platforms under development. Although mobile platforms are mostly designed with universal range of use, some tasks are more suitable than other ones. Based on selection of success criteria and key-parameters, requirements can be modelled.
- To develop a method for testing the efficiency key parameters of a mobile platform, it is required to validate the design concept. The method must be easily usable during the prototype testing phase and allow standardized testing of efficiency parameters regardless of platform energy source, locomotion and steering types.
- To present the overall energy efficiency of a mobile platform in way that describes its design suitability in the field of application. The efficiency factors can be converged into the platform profile, which clearly presents its energy consumption distribution and sources of inefficiencies. Also, platform profile should enable comparison of performance with the requirements of the task and mission.
- To apply the evaluation results in the product development in order to improve the early design phase. It is required to acquire a knowledge library and engineering toolkit that allow easy platform design evaluation, comparison and efficiency predictions. Different platforms must be used for the testing task, which can be completed by all of them to obtain comparative results.

2. REQUIREMENTS FOR PRODUCT DESIGN

2.1 Requirements and key parameters for mobile platform design

Figure 2.1 shows the mechatronic product development process in a simplified way. The current research is targeted to support an early design phase. Through validating many existing mobile platform prototypes, the results can be used to predict the future concept design performance and energy efficiency in the planned field of application. Then it is possible to decrease the early design phase time considerably and reach the detailed product design phase quicker with the optimal concept.

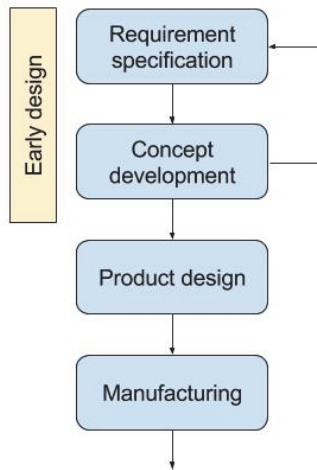

Figure 2.1. Mechatronic product development cycle.

As discussed above, early stage product development obtains considerable benefit from the model-based approach. To design successful and energy efficient moving robotic platforms, it is essential to have proper context, main interactions and a function model. As UGVs have many uses, they tend to be designed universal and versatile to accomplish several different tasks. This can be modelled with *Use Case (uc)* diagram of SysML (Fig. 2.2).

UGV is operated by an operator who arranges the missions, does the maintenance and monitors the whole process. The mid-class platform carries some payload (cargo, tools etc.) and interacts with the environment, including the weather, terrain and obstacles, also the target to be manipulated. Depending on its level of autonomy, UGV decides about its navigation to the target and tool operations while maintaining the safety level with random persons that may get in its way. The energy efficiency is defined by the processing performance a UGV shows during these interactions.

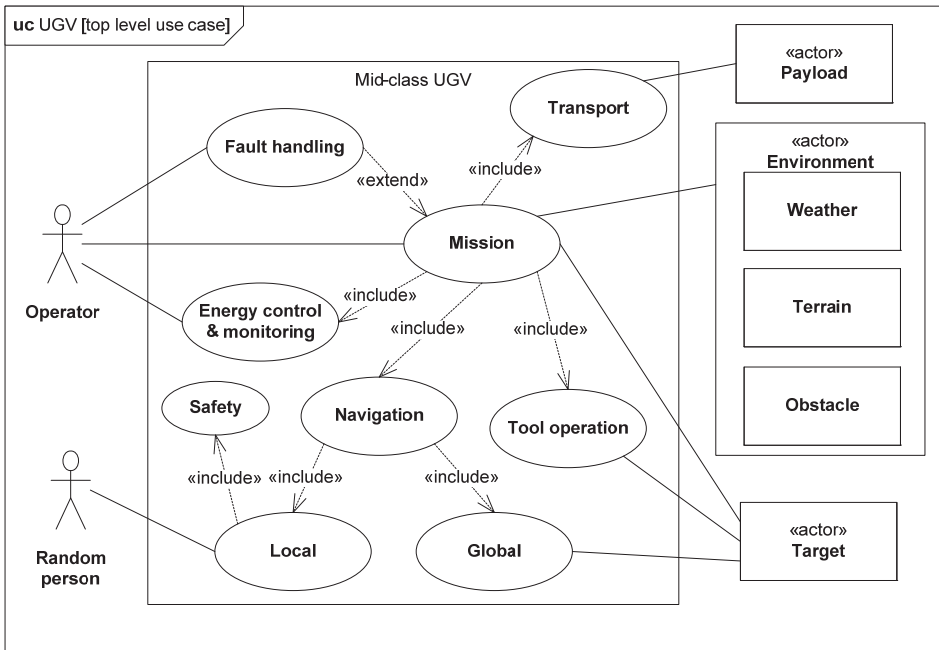

Figure 2.2 UGV general use cases.

Performance is a composite property which includes power, traction, speed and other components that can be evaluated by time or quality:

- more tasks processed successfully in a given time;
- shorter task processing time;
- higher quality of task processing.

As the performance indicators include the measure of process duration, the operation of a mobile platform can be limited in different ways:

- goal-limited – mission continues until the goal is reached;
- resource-limited – mission lasts continuously depending on how the unprocessed work is generated and availability of resources for the platform.

As resource-limited mission can virtually be non-stop, e.g. UGV battery is continuously loaded with solar cells, the efficiency assessment requires extraction of some time frame or driving distance. In addition, generic missions for moving robotic platforms can be divided into three parts by actions:

- covering a distance or an area – driving or transporting a load to the target;
- performing a task – for example, loading cargo, taking a sample;
- support functions – navigation measurements, communication tasks and other secondary functions.

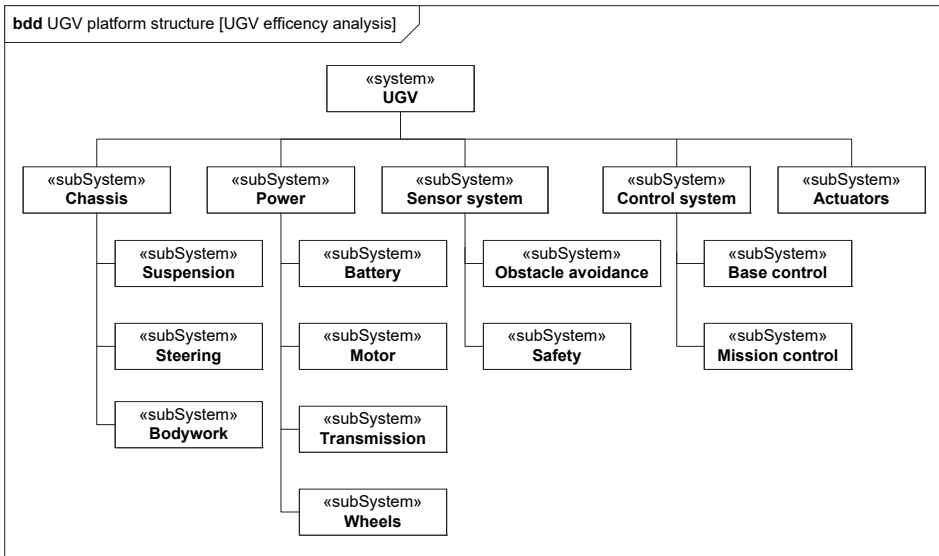

Figure 2.3 UGV general structure block diagram.

Tasks and missions in the field of particular UGV application determine the requirements for its design. Every platform subsystem (Fig. 2.3) is used to satisfy the requirement of the corresponding task. For example, steering subsystem provides manoeuvrability in tight spaces and its design defines operating efficiency at a certain level.

Careful observation of mission environment, possible track soil condition, obstacle properties and other factors ensure a precise requirement list. Usually, UGV missions include several different tasks, such as drive to location, operate tool, send information. For every task, a requirement list can be composed (Fig. 2.4). Further merging the requirements of tasks gives a requirement list for a mission.

The essential platform properties required by a given task are organized in Table 2.1. These are measurable directly or statistically. Every task requirement somehow limits UGV properties. For example, when UGV carries its batteries or fuel along, the energy efficiency is limited by available energy source capacity; with one charging cycle, it is usually desired to have as long operating time as possible.

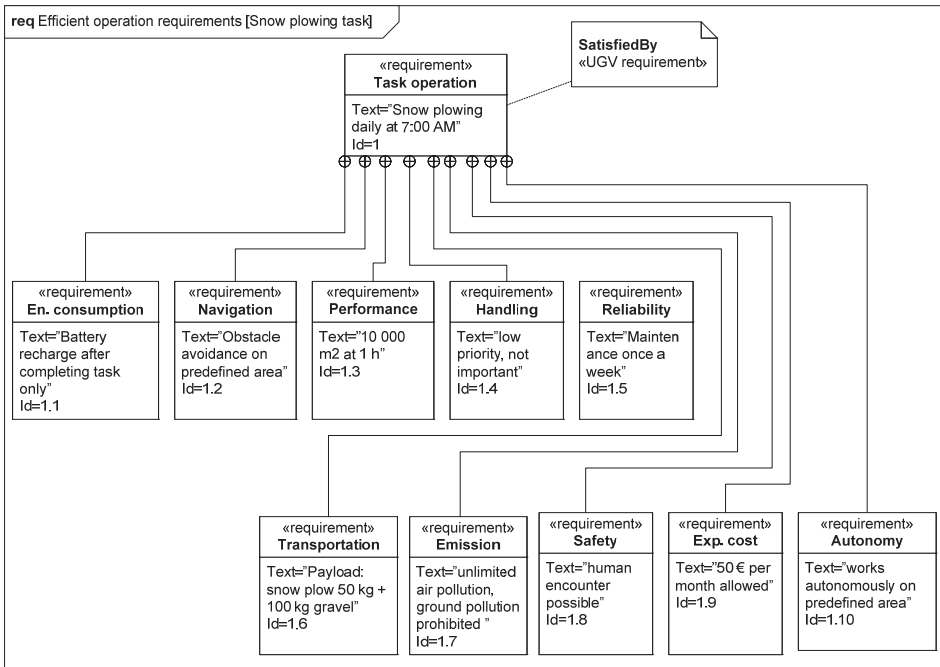

Figure 2.4 Task requirements for a snow plowing UGV.

Table 2.1 UGV properties established by a task

No	Property	Measure	Limiting factor
1	Energy consumption	energy	energy source
2	Navigation	distance driven	environment knowledge
3	Performance	time	task completion time
4	Handling	acceleration	interaction fragility req.
5	Reliability	number of failures	maintenance interval
6	Transportation	mass	payload capacity
7	Emission	mass	allowed pollution amount
8	Safety	time to collision	allowed limits
9	Exploitation costs	cost	cost upper limit
10	Autonomy level	ratio	operator availability

Navigation algorithms, environment observing capabilities and adaptivity are important when the task demands UGV autonomous driving in an unknown terrain. Handling is important when transporting fragile instrumentation and is expressed by acceleration - smooth driving is characterized by low acceleration. Reliability is indicated by the number of faults or its effect on performance. Safety is an important factor when encountering obstacles and especially when robots work together with humans or interact with them physically. Pollution amount is important when the environment should not be considerably affected from contamination, e.g. UGV cannot usually use diesel engine indoors. Platform

cost defines the general borders of development and usually narrows the possibilities of applying technical solutions. In addition, production and operational costs of a given platform define its cost-efficiency, which is very important in consumer market.

Some qualities of UGV design like appearance are not so clearly measurable. Appearance has usually a negligible effect on a robot's efficient operation, so it can be discarded on most applications. However, on the other hand, it may have considerable impact on marketing and sales, making the external design as important as any other technical parameter.

As an objective assessment of UGV properties is desired, it is important to quantify them numerically rather than do subjective scoring and judging. Some parameters can be obtained statistically, like the number of failures during a mission. The effect of a failure (e.g. flat tire etc.) on vehicle performance is directly measurable.

An appropriate list of requirements enables creation of corresponding requirement profiles for missions. Depending on mission goals, single tasks are more or less important, often and seldom performed, and some kind of priorities are needed. For example, transportation capacity is the most important factor for a vehicle used for carrying gravel to building sites. In addition, many task contributing key-parameters contradict each other, which makes assigning priorities and their comparison a comprehensive task. For example, vehicle mass is a very important factor for energy efficiency, however lightening the chassis decreases also the payload carrying capability. Similarly, tire rolling resistance is controversial to traction on offroad track and powerful motor shortens travelling times but consumes more energy. To solve this, priorities are assigned by scaling the parameters in comparison with each other. This will increase or decrease the importance of its properties to UGV efficiency profile.

2.2 Typical mobile robot platform design types

Tasks in different areas of application set versatile and contrary requirements to UGV hardware and software design. During the processing of the task, UGV is encountering real-time and real-condition interactions with the surrounding environment and terrain track (Fig. 2.5). It is clear that platforms can be developed with a universal concept in mind; still, they are not usable with 100 % efficiency on all possible conditions and can realize their optimum performance only on narrow conditions. Therefore, platform efficiency can only be presented according to a given track and environment circumstances and describing the efficiency involves measurements of all interaction participants.

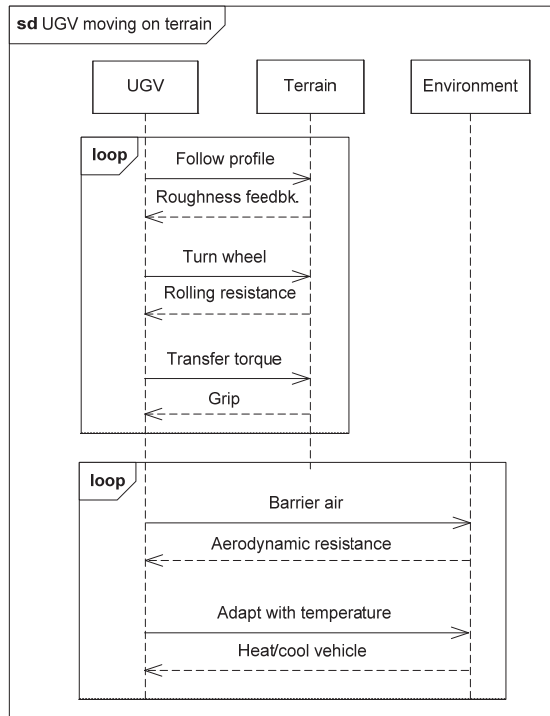

Figure 2.5 Interactions during UGV operation.

Completion of a successful mission can be achieved by using different technical solutions for platform design. The layout of a mobile platform is determined mainly by the locomotion and steering principles. Besides energy consumption, they affect other important properties of UGVs. Those important choices are made on an early design phase corresponding to the planned terrain, tasks and other aspects. Depending on the requirements, motion parameters can be achieved using very different approaches. Locomotion also sets the base for traction efficiency and rolling resistance, both of which have substantial impact on energy efficiency. When a designer has to choose a motion type, it is very important to consider as many options as possible at the conceptual design stage in order to find an optimal solution for the given problem.

Some most common locomotion design solutions are shown in Fig. 2.6. As wheels have low rolling resistance, caterpillars have superior traction. An additional wheel lifting or caterpillar shape altering mechanism can be used for a climbing aid in order to improve the driving efficiency.

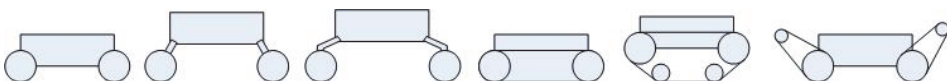

Figure 2.6 Basic types of mobile robotic platform.

To transfer the power to ground for moving the vehicle, different principles can be used:

- wheels,
- legs,
- caterpillars,
- wheel and leg combination (aka “wheg”),
- screws (in amphirol),
- air pressure pads (in hovercraft).

Most important requirements for torque transfer element performance are presented in Fig. 2.7. Decision must be made between traction and rolling resistance while keeping in mind allowed torque element contact pressure and the size and shape of the obstacles encountered.

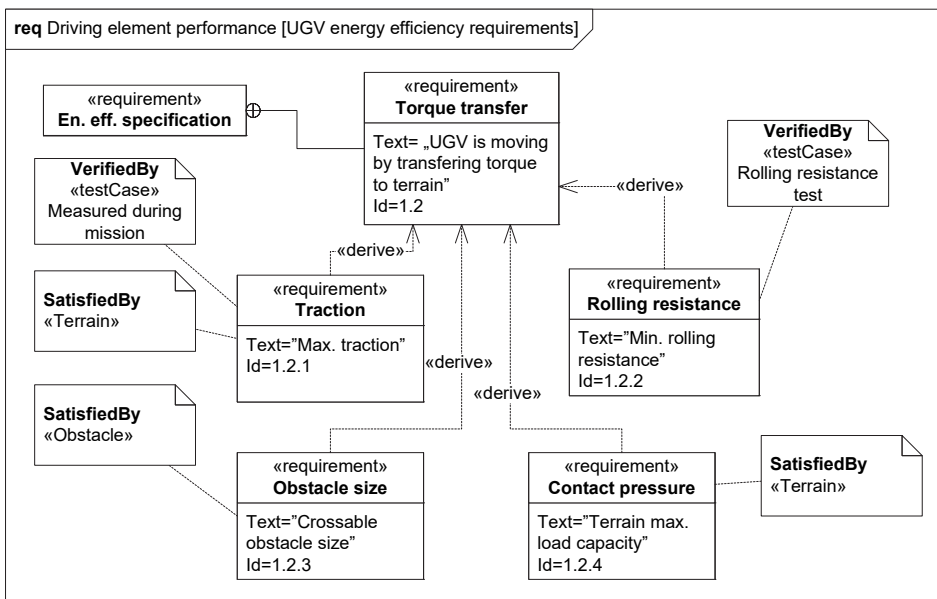

Figure 2.7 Driving element performance requirements.

Steering principle defines the manoeuvrability of the vehicle over obstacles and navigation versatility [52]. Figure 2.8 shows common vehicle steering principles:

- Ackermann type - wheels follow different radii using linkage (ordinary cars);
- frame articulated - wheels turn with body linkage (heavy front loaders);
- axle articulated - axle is turned around the centre point (horse carriages) [53];
- skid - wheels turn in opposite directions (miniloaders, excavators);
- independent - each wheel angle is separately controlled (several road construction vehicles);

F. omnivheeled – rollers added to wheel enable manoeuvring sideways without changing the wheel position.

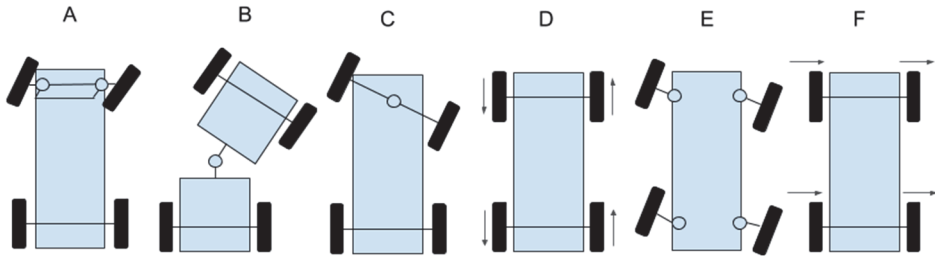

Figure 2.8 Common steering principles

In the current research, all available mobile platforms use wheels and steering options include common Ackermann type and frame articulated steering with skid capabilities. Nevertheless, the methods are equally usable for other locomotion and steering types.

The field of application designates principles to be used on a platform. Example model (Fig. 2.9) explains how the steering principle is determined by the efficiency requirements on the platform manoeuvrability. Several factors are involved in parallel, like cost and wear. The aim is to find the optimal solution, i.e. which factors ensure maximum efficiency. If the priority is good high speed performance and low tire wear, the obvious choice is Ackermann type steering geometry, which enables good energy efficiency on high speed vehicle. On the other hand, when zero turning radius and manoeuvrability in tight space are important, skid steering is the choice, which enables good manoeuvring and energy efficiency in high obstacle density area.

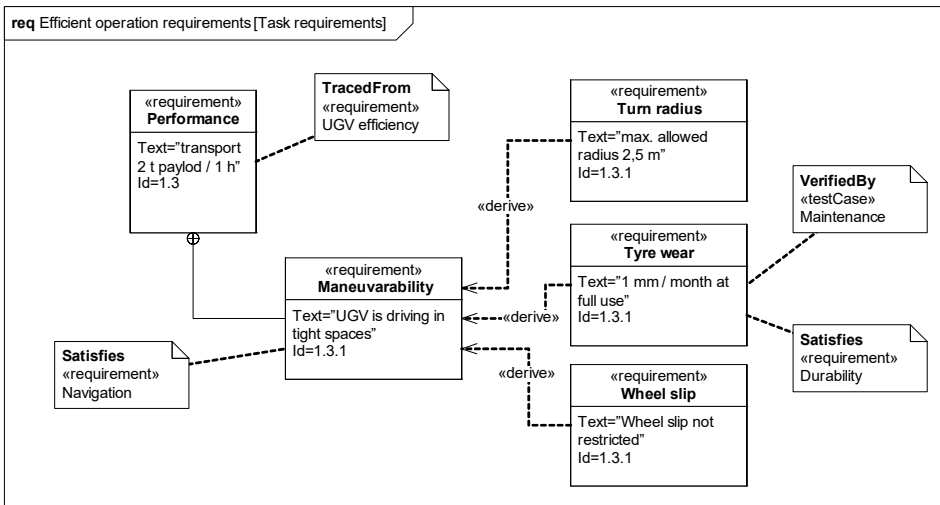

Figure 2.9 Task requirements for manoeuvrability.

2.3 Conclusions of requirements for product design

- Focus in this section was on the compilation of a requirement profile for a universal UGV that can accomplish several tasks.
- The energy efficiency is defined by the processing performance UGV shows during interactions with environment and target.
- UGV design is determined by the task and mission. Therefore, the task requirement list is the basis for platform efficiency evaluation.
- Task requirements were grouped into logical groups that present the properties of successful and efficient task completion. Exact task profile helps to search ideal platform design that performs the task with maximum efficiency.
- Opposing task requirements are managed by assigning priorities to properties by scaling the parameters in comparison with each other.
- The layout of a mobile platform is determined mainly by the locomotion and steering principles. With tool operation, these consume most of the available energy to move the vehicle. The principles also define platform capability and suitability for a particular mission.

3. EFFICIENCY METRICS

3.1 Energy consumption model

Linking the UGV energy consumption with its design properties requires investigation of energy distribution while it is converted from source to useful work. It is necessary to find relationships between sensor data and key-parameters. During the UGV task processing, energy distribution can be described using fundamental relations in physics. In the context of the current research, the descriptions of relations need not to be complicated but rather practically usable. Similar simplified approaches are described in literature [54] for estimating the platform efficiency. Due to large sets of several sensors data, analysis methods benefit from data mining and machine learning to compute indicators.

The autonomous UGV uses its energy resources for accomplishing a given mission, which in most cases includes performing a task - driving, tool manipulation and supporting functions. Because of power unit and transmission internal parasitic losses, it is always less than 100%. While converting energy into useful output, the efficiency is evaluated in several stages:

1. Input energy transformation into useful output. For example, electric energy produced by battery is converted into wheel torque.
2. Output transformation into useful work. For example, torque is applied to wheels only when they have enough grip to move the vehicle.
3. Work planning and processing to complete a mission successfully. For example, a vehicle is driven around obstacles through the shortest track with minimal energy consumption.

UGV is overcoming the resistive forces by using torque generated by its power unit. Mobile platforms can be equipped with several common power unit types, which have different properties and internal efficiency factors:

- gasoline ICE, mean efficiency factor estimate is 30%;
- diesel ICE, mean efficiency factor estimate is 45%;
- brushed DC electric motor, mean efficiency factor estimate is 80%;
- BLDC electric motor, mean efficiency factor estimate is 90%;
- hybrid motor (ICE + electric motor), mean efficiency factor estimate depending on the layout is around 50% – 70%;

Similarly, UGVs can be equipped with several transmission types that in turn add parasitic losses to the system. The most common are:

- direct drive (motors in the wheels), 100% efficiency;
- spur, bevel, helical geared drive, usually 93% – 98%;
- planetary gear drive, usually 96% – 99%;
- worm geared drive, 50% – 90%;
- belt drive, 95%;
- hydrostatic transmission, around 80%.

First, energy consumption measuring is needed using current or fuel consumption depending on the platform power unit. Energy consumption can be expressed in two ways:

- units of energy per fixed distance or
- units of distance per fixed energy unit.

In the comparison of different vehicles, it is reasonable to measure the energy consumption while the fixed distance is travelled. As there is no standard for comparison and evaluation, particularly for UGV dynamics energy efficiency, it is reasonable to adapt the metrics – Watt-hours per meter. Transforming the energy consumption of different energy sources to units of Joule per meter, vehicles can be compared regardless of the energy source. Specific energy is commonly used for emission assessment in transportation, it is 48 MJ/kg for diesel fuel while lithium-ion battery holds roughly ten times less.

Energy consumption analysis requires a detailed analysis of the resistive forces that oppose a vehicle's motion. The power consumption study utilizes a typical vehicle longitudinal dynamics model [55], which was adapted for UGVs during the current research. Vehicle power consumption model utilizes resistive forces as key factors (Fig. 3.1):

- acceleration F_a ,
- rolling resistance F_r ,
- track gradient F_g ,
- aerodynamic drag F_d ,
- working operation resistance F_p ,
- vehicle internal resistance C_i ,
- electronic equipment power consumption P_e .

$$P(t) = (F_a + F_r + F_g + F_d + F_p + C_i)v(t) + P_e(t) + \varepsilon(t), \quad (3.1)$$

where $\varepsilon(t)$ is the model error. Key factor assessment requires composition of time dependant profiles for a vehicle: like driving style profile, track surface roughness profile, track gradient profile that can be composed based on real-condition testing measurement results. As UGV is usually processing useful work, the resistance force from the working operation is also added, e.g. UGV is pushing/pulling something. Vehicle internal resistance is a sum of power converting losses, e.g. in gear drives.

Decelerating or braking is the opposite of accelerating force. If braking is regenerative like it is usual for vehicles of road driving, accelerating force F_a is negative. In the context of the current research, UGVs are mainly used in offroad terrain at relatively low speeds. In these cases, none of them can benefit from regenerative braking, it is not used and $F_a = 0$ during braking.

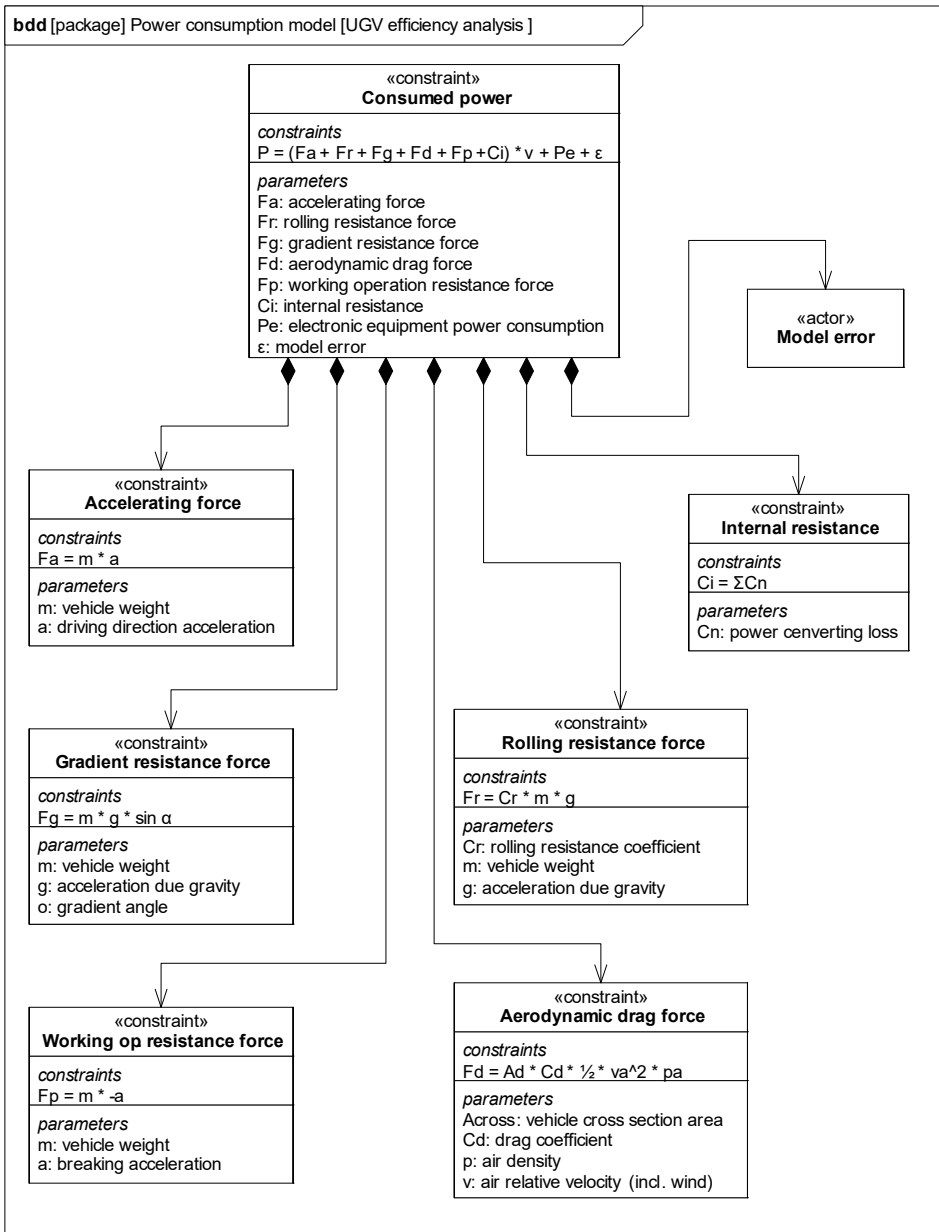

Figure 3.1 Restriction force constraints package diagram.

3.2 Evaluation of resistive forces

Track and vehicle wheel interaction has significant impact on energy efficiency [56]. The rolling resistance coefficient can be measured separately for a given torque transfer element or taken from the database. Tire rolling resistance force

is a constant value based on the resistance coefficient C_r , vehicle mass m and acceleration due to gravity g (Fig. 3.2):

$$F_r = C_r mg . \quad (3.2)$$

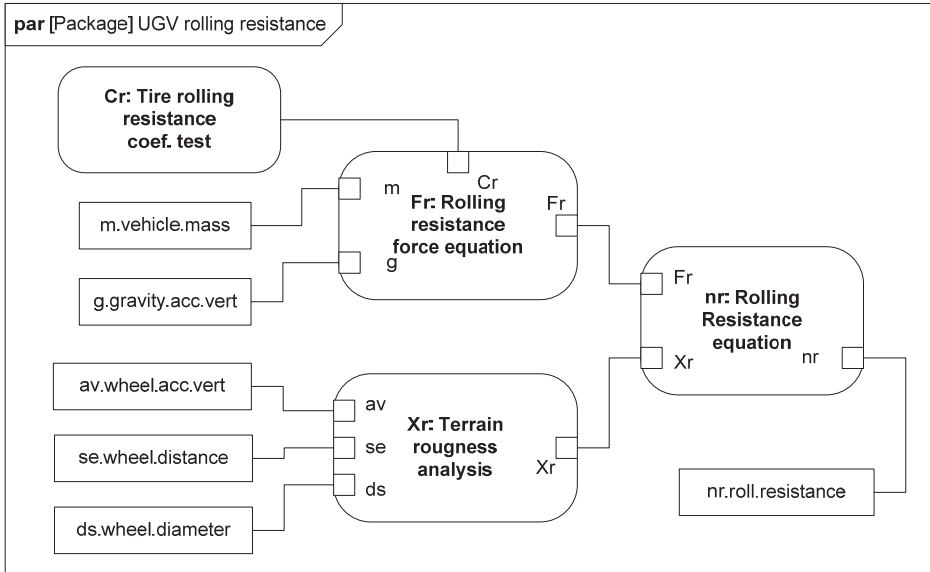

Figure 3.2 Parametric diagram of UGV rolling resistance.

There are several techniques of measuring tire rolling resistance [57]:

- drum test of tires – results available and usable through the literature of testing results;
- trailer method – separate towable trailer is built for measuring tire created resistive torque on different surfaces;
- coast down method – vehicle is accelerated to a certain speed and then left to roll freely on neutral gear;
- fuel/current consumption method – can be used as a comparative method of different tires in very steady conditions (indoors).

In addition to tire rolling resistance, overcoming track roughness needs more energy. Therefore, besides tire parameters, rolling resistance force depends on terrain surface roughness and resistance to rolling. If one of the above rolling resistance tests is used, the measurements must be carried out at least in two conditions, easy (asphalt, concrete) and difficult (loose soil) to find the change of the terrainability factor between condition limits. Soil resistance is included as a consumed energy measure and can be subtracted when tire rolling resistance and track roughness are known. Track roughness is measured through vehicle wheel vertical acceleration [58] (Fig. 3.3), scaled with speed factor and taken into account to calculate the summary rolling resistance of the platform.

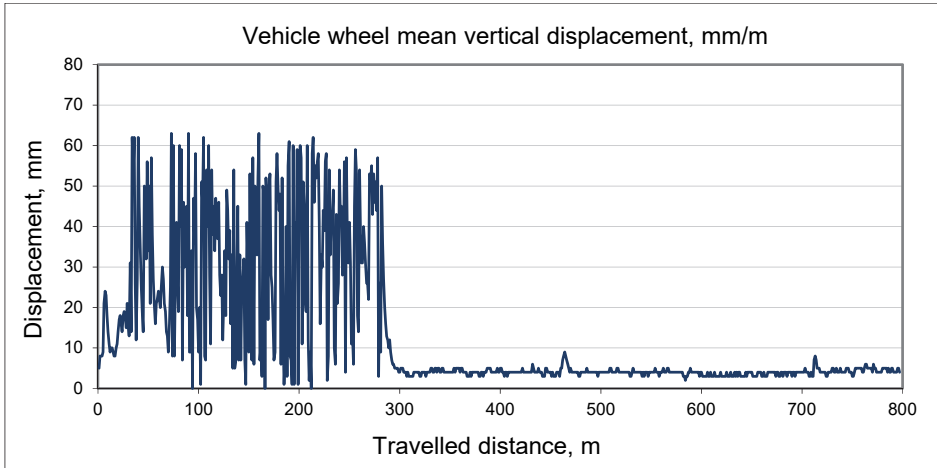

Figure 3.3 Track roughness measure while a vehicle is driven from rough to smooth pavement.

In the case of UGV operated offroad and at low speeds, vehicle bodywork has little impact on the performance. Inversely, when the UGV driving speed is important, the aerodynamic drag has considerably larger effect on energy consumption. As the wheel rolling resistance is linear, aerodynamic drag grows quadratically with speed (fig. 3.4). The aerodynamic drag resistive force of the vehicle bodywork is calculated from the cross-sectional area of the vehicle body A_d , the coefficient of drag C_d , air density ρ_a and relative velocity of the air v_a (wind):

$$F_d = A_d C_d \frac{v_a^2 \rho_a}{2}. \quad (3.3)$$

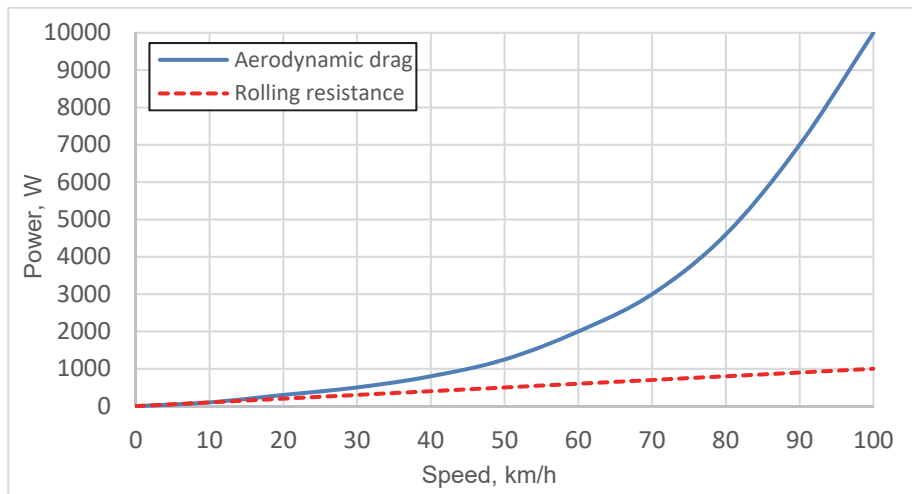

Figure 3.4 Typical resistive power graph of a light vehicle encountering aerodynamic drag and rolling resistance.

Terrain gradient has quite large effect on energy consumption, especially on offroad tracks. In many cases, frequent occurrence of the gradient has a self-withdrawal effect because positive and negative slopes in generally flat landscapes are usually accompanied with the opposites. The resistance force of the track gradient is calculated from the vehicle mass m and the track gradient angle α (Fig. 3.5):

$$F_g = mg \sin \alpha . \quad (3.4)$$

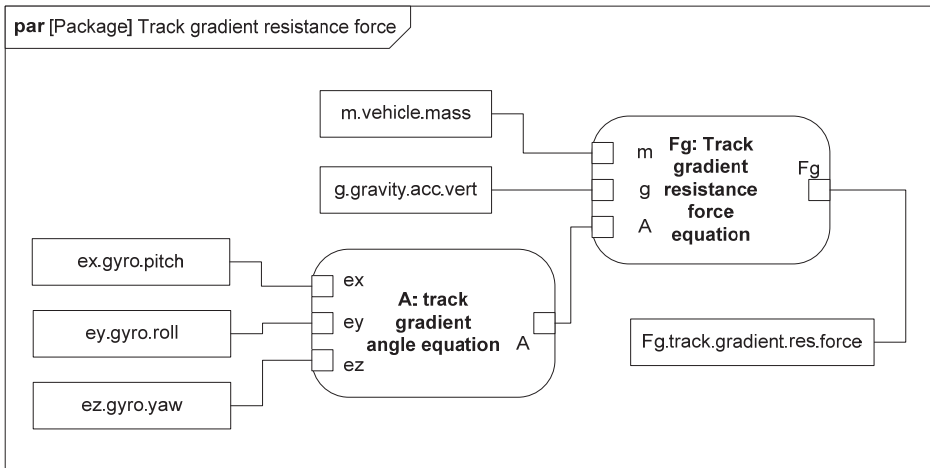

Figure 3.5 Parametric diagram of track gradient resistance.

The remaining resistive force is the working operation resistance F_t , which should be maintained below the drawbar pull force F_p for successful operation. Therefore, the drawbar pull force is the amount of useful horizontal force available for the working operation, pushing or pulling a load [20]:

$$F_p = F_a - F_n . \quad (3.5)$$

UGV can use its available drawbar pull force for plowing snow, pulling cargo trailers and for other functions. When an UGV is designed for a given task, the positive drawbar force ($F_a > F_n$) is desired. Excessively high drawbar force capacity results in poor energy efficiency due to increased power (high fuel/current consumption), rolling resistance or platform mass. The drawbar force is at its maximum during takeoff while pulling a load and it decreases steadily while the vehicle speed increases.

3.3 Energy efficiency measures

Regardless of UGV motor type, it has its most effective turning frequency where energy consumption is optimal. A motor operating below or above optimal frequency increases the wear and decreases the efficiency factor. This indicates that the power source is sized inappropriately. The load efficiency factor is measured during the test or the specific power curve is taken from a database if available. Load measure acts in opposite to the drawbar pull but the drawbar pull can reach its limit due to low grip much sooner than the load. In the case of the electric motor, the load factor η_L is based on the measured current ΔI on the given time stamp and the maximum allowed current I_{max} :

$$\eta_L = \frac{\Delta I}{I_{max}}. \quad (3.6)$$

Total current consumption of the platform consists of two parts - passive and active. Passive consumption in idle mode keeps the UGV systems and its actuators alive and responsible. The active consumption is present when UGV accomplishes useful tasks like driving from one point to another. Inside the vehicle, basic energy conversion efficiency is a ratio between the input (all consumed energy) and the output (useful energy):

$$\eta = \frac{E_{out}}{E_{in}}. \quad (3.7)$$

Acquisition of electric energy consumption from sensor parameters is modelled with the parametric diagram in Fig. 3.6. Instantaneous energy consumption of an electric vehicle while driving can be calculated from the measures of the consumed current I_{Δ} and the battery voltage U_{Δ} during the given time t , which enables use of dynamics efficiency metrics in units of Wh/m:

$$E = \frac{\Delta I \Delta U t}{s}. \quad (3.8)$$

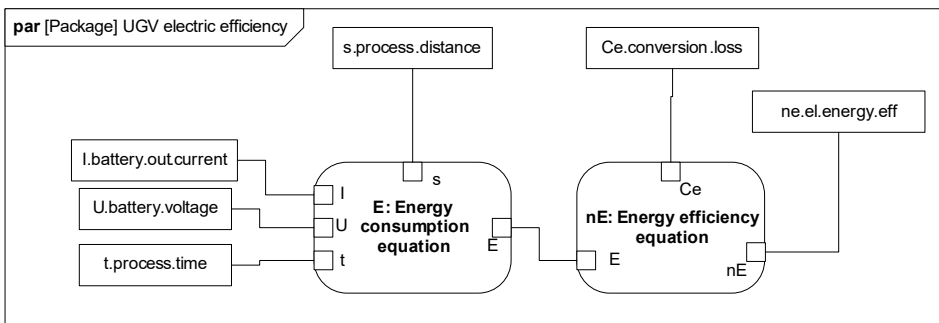

Figure 3.6 Parametric diagram of UGV electric energy efficiency.

In the case of an ICE powered platform, equal energy consumption can be calculated using liquid fuel flow Q measurements and the specific energy conversion coefficient C_f :

$$E = C_f \frac{Qt}{s}. \quad (3.9)$$

After considering the resistive forces to plot the UGV energy distribution, higher level of efficiency is evaluated by the vehicle management system (VMS) which uses the design elements optimally to process the mission. VMS performance determines the navigation, handling, driving style, and the efficiency of behaviour. Therefore, the efficiency metrics should involve the driving style and smoothness indicators.

The driving style parameters are dynamic and based on the travelled distance over time units. The acceleration/deceleration defines driving smoothness while speed is a compromise of energy efficiency and durability versus task processing time. Like on ordinary cars, there is usually an optimal speed interval where energy efficiency is highest and which should be desired by the platform VMS.

Stops without processing a task (e.g. for measuring the environment, calculating the route) are unwanted and lower the overall efficiency. The number of stops is counted during the test and their time is measured. In case UGV uses an ICE, a similar parameter, though not equal, is idling time. Idling the engine should generally be avoided by VMS.

Safety can be quantified in different ways. It expresses the efficiency of encountering obstacles and humans without colliding or threatening them. Statistically, it is the number of incidents but accurate information requires an observer, which is not suitable for a self-contained measurement system. Instead, it is also correlated to the mean value \bar{s} of the minimum distance s_n to each n number of encountered obstacles through the entire mission measured by all robot sensors:

$$\bar{s} = \frac{1}{n} \sum_{i=1}^n s_n \quad (3.10)$$

The maximum value is produced on an obstacle free environment, which means 100% level of safety. Low values indicate possible collisions and degrade the overall result, which correlates to the number of incidents. Naturally, in practice an autonomous vehicle cannot keep it as far away from obstacles and humans as possible, but has to decide sufficient and possible gap during navigation.

Driving smoothness as kinetic intensity is related to the frequency and intensity of accelerating and braking [59] and also describes safety during navigation. Highly correlative measure of driving smoothness is the time to collision, such as distance to an obstacle s_o divided by the vehicle driving speed v [60]:

$$t_c = \frac{S_o}{v} \quad (3.11)$$

VMS with a desire to drive smoothly will not approach an obstacle in such way that the rapid braking is necessary to avoid collision. In addition to acceleration, highly correlative to driving smoothness is instantaneous current/fuel consumption.

Trajectory smoothness is a way how navigation system generates the platform trajectory during an operation and is a measure to navigation efficiency [28]. Smooth trajectory enables optimization of the acceleration profile and provides energy, time and vehicle durability savings. Trajectory smoothness is described by a curvature on the track points. The curvature can be calculated using combined magnetometer and gyroscope measures to obtain the heading of a robot on each time stamp. To take smoothness and trajectory length into account simultaneously, mean curvature index \bar{k} is calculated based on the curve radius R_n on each n distance segment:

$$\bar{k} = \frac{1}{n} \sum_{i=1}^n \frac{1}{R_n}. \quad (3.12)$$

To compare the recorded trajectory curvature with an ideal trajectory, navigation efficiency ratio is calculated. This ratio is an ideal route length s_i related to the actually covered route s_r recorded using the GPS tracker system:

$$\eta_n = \frac{s_i}{s_r}. \quad (3.13)$$

The ideal route is calculated on the map using intelligent algorithms for finding the optimal route. As the vehicle wheel slipping on loose grounds affects the driving wheel covered distance, its true value s_r must be measured as a sum of waypoints described with the GPS-coordinates. In geodesy, the spherical law of cosines is used to calculate the distance between two points Δs described with latitude (X_1, X_2) and longitude (Y_1, Y_2) and earth radius $R_e = 6371$ km is expressed as:

$$\Delta s = \cos^{-1}(\sin X_1 \sin X_2 + \cos X_1 \cos X_2 \cos(Y_2 - Y_1))R_e. \quad (3.14)$$

For an area covering type of tasks, UGV energy efficiency can be expressed as an efficiency ratio of the coverable area A_c and the obstacle area A_o unreachable, related to the consumed energy E [34]:

$$\eta_e = \frac{S_c - S_o}{E}. \quad (3.15)$$

Considering internal power conversion losses, the tractive efficiency is determined as the ratio of the drawbar pulling power P_d to the power P_p delivered by a power unit:

$$\eta_d = \frac{P_d}{P_p}. \quad (3.16)$$

Besides internal losses, there is a notable power loss in tire and track surface contact. Corresponding driving element traction efficiency ratio [61] (Fig. 3.7) is the distance covered without a slipping s_i (ideal route) and the distance covered by a driving element s_e (measured with a wheel encoder):

$$\eta_t = \frac{s_i}{s_e}. \quad (3.17)$$

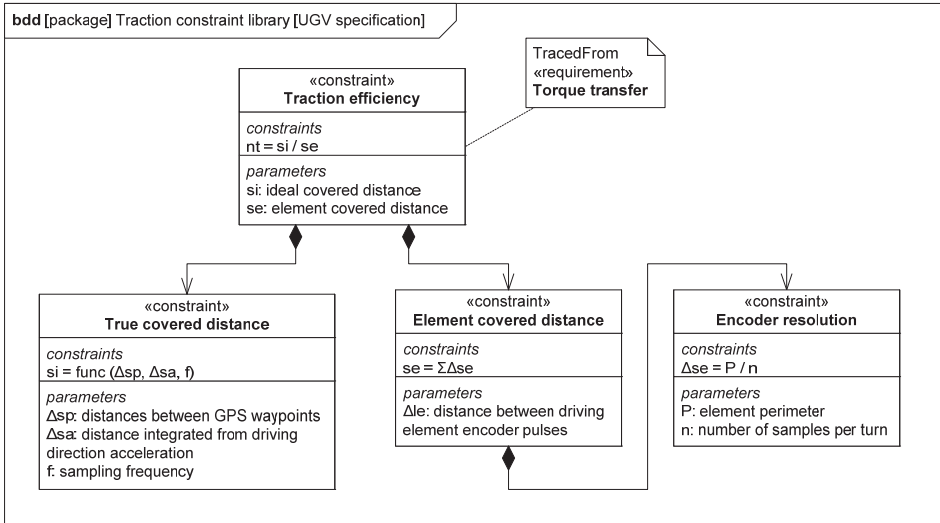

Figure 3.7 Traction efficiency measurement.

As each ratio represents one section of energy transformation into useful work during the task, they are related to each other. The platform total energy efficiency ratio η_Σ between 0% and 100% is the sum of all efficiency ratios:

$$\eta_\Sigma = \eta_e \eta_t \eta_n. \quad (3.18)$$

Energy consumption is easily measured directly but this ratio will answer the question “how much energy is lost during the task?” While allocating the limits of efficiency for a given design, best possibilities for improving energy consumption become also clearly visible.

3.4 Operational efficiency measures

In addition to energy based efficiency measures, UGV operational efficiency is evaluated similarly [37, 62]. Though the operational efficiency is not directly related to the energy consumption measure, efficient operation always translates to energy efficiency improvements.

The autonomy ratio is a measure of time t_o spent by the operator to achieve the robot operation time t_r :

$$\eta_a = \frac{t_r - t_o}{t_r} \quad (3.19)$$

For example, if the operator spends 12 min during the mission to input navigation information and interact or conduct the UGV during process, which enables successful UGV operation for an hour, the autonomy ratio is 80%. Fully human teleoperated UGV has 0% autonomy ratio, while advanced autopilot allows ratios close to 100%.

Reliability is often evaluated as the MTBF, ranging usually from 6 h to 24 h [63]. Considering relatively good engineering level, test missions are usually too short for calculating MTBF, instead, the number of failures and their types should be counted if present. As safety correlates to trajectory smoothness and time to collision, its margin η_s can be calculated using the limiting yield acceleration a_{lim} and the maximum operating acceleration a_{max} :

$$\eta_s = \frac{a_{lim}}{a_{max}} \quad (3.20)$$

As safety cannot be fully characterized using acceleration, the number of safety incidents should be counted statistically over a long-term UGV operation. The mean time between safety incidents can be measured similar to reliability.

In the context of the current research, failures might terminate or decrease UGV operational efficiency. There is a difference between reliability and safety incidents by their effect on platform operation whether incidence reduces platform performance or has no effect on it. Failures having small effect can be detected, for instance, by measuring repeated tasks to find performance deterioration through wear. The corresponding reliability ratio is the full performance measured by the time t_{fp} compared to the reduced performance measured by the time t_{rp} :

$$\eta_r = \frac{t_{rp}}{t_{fp}} \quad (3.21)$$

Similarly, it is possible to calculate safety ratio where 100% means no incidents occurred during the operation. Reliability and safety are not properties for direct definition of the efficiency but that must be met when operating.

Finally, to estimate the efficiency of autonomous platform purchasing and operating cost C_{ugv} , comparison with the cost of the traditional technology C_{trad} can be the criterion of efficiency:

$$\eta_c = \frac{C_{trad}}{C_{ugv}} \quad (3.22)$$

As can be seen, over 100% cost efficiency means that it will be less expensive to operate than by a traditional solution. In this case, use of an unmanned intelligent technology is obligatory.

3.5 Uncertainty in the measurement system

The efficiency indicators and resistive forces are calculated based on vehicle dynamic driving, terrain and environment properties that are tracked by a set of sensors during the real-condition test. When reporting efficiency indicators to the UGV design and judging about a platform design, the quality of the measurement process and result reliability must be observed [64]. Without estimating the uncertainty of the measurements, the different tests and platforms cannot be compared, although it is the basis of the analysis.

Most output efficiency indicators are not measured directly, rather they depend on several input measures and are altered by a data processor (Fig. 3.8). In resistive force calculations, different direction accelerations are highly involved. The source of data is provided by a 3-axis acceleration sensor that is mounted into a vehicle in an unknown position. As it is an inertial type microelectromechanical system (MEMS) sensor, the output is greatly affected by vehicle vibration. Also, the electric motor has negative electromagnetic effects that add noise to analog circuits.

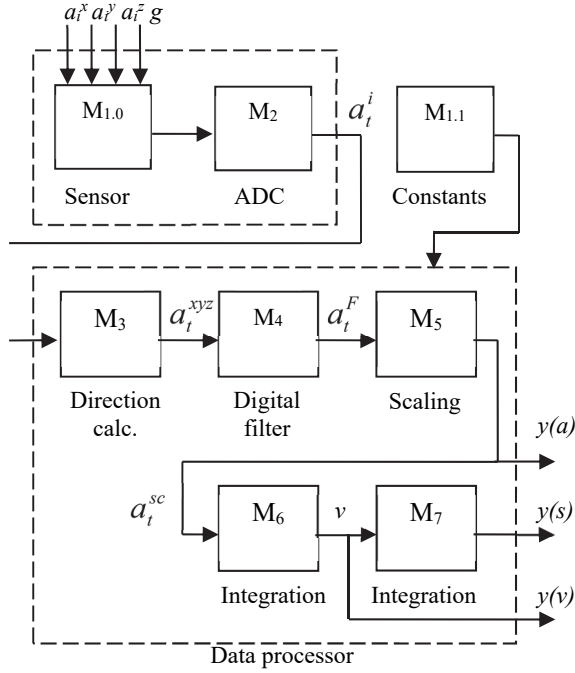

Figure 3.8 Acceleration measurement system setup.

The output value recorded into memory at every time stamp t is the acceleration arithmetic mean value \bar{a}_i^t measured and calculated for a time stamp:

$$\bar{a}_i^t = \frac{1}{n} \sum_{i=1}^n a_i^t, \quad (3.23)$$

where the standard deviation estimate $u(\bar{a}_i^t)$ is established with the statistical analysis:

$$u(\bar{a}_i^t) = \sqrt{\frac{1}{n-1} \sum_{i=1}^n (a_i^t - \bar{a}_i^t)^2}. \quad (3.24)$$

The sources of uncertainty for sensor axes are output bias, scale factor, nonlinearity and asymmetry of axes and sensitivity [65]. A sensor is calibrated at nominal voltage in factory. Therefore, a precision voltage regulator must be used. The systematic effect ε_B of the sensor zero acceleration level bias causes constant linear growth of the systematic effect of the velocity depending on the measurement time t when integrated [66]. Double integrating causes the position systematic effect $\varepsilon_s(t)$ to grow quadratically in time:

$$\varepsilon_s(t) = \varepsilon_B \frac{t^2}{2}. \quad (3.25)$$

Additional systematic effect that affects the output is the bias ε_{imp} caused by the environment temperature that is highly nonlinear. The sensor is calibrated at the temperature 25 °C by the manufacturer. The effect on speed and position coincides with previous assumptions. All systematic effects are compensated with correction δ_i .

Sensor's output random deviation is caused by thermo-mechanical white noise whose mean value is zero, correction $\delta_{wn} = 0$ and experimental standard deviation is s_{wn} , which estimates the standard deviation σ . Noise raises velocity standard deviation proportionally to the measurement time $t^{1/2}$ when integrated and position standard deviation $s_s(t)$ proportionally to the measurement time $t^{3/2}$ when double integrated:

$$s_v(t) = s_{wn} t^{1/2} \sqrt{\Delta t}, \quad (3.26)$$

$$s_s(t) = s_{wn} t^{3/2} \sqrt{\frac{\Delta t}{3}}, \quad (3.27)$$

where Δt is the time between the measurement points. The change over time of the systematic effect ε_B of the sensor zero acceleration level is similar, which raises the standard deviation of the velocity proportionally to $t^{3/2}$ and the position standard deviation to $t^{5/2}$. All output values measured with the sensor are affected by the aforementioned effects and the correction function to values is given:

$$a_i = f(x_{res}, x_{wn}, x_g, x_{tmp}, x_b, x_{sc}, x_{nl}). \quad (3.28)$$

The measurement model for the inertial MEMS sensor is expressed with the random and systematic effect corrections δ_i added to output y :

$$y = \bar{a}_t^{sc} + \sum_{i=1}^n \delta x_{sens}^i + \delta x_{res} + \delta x_{wn} + \delta x_g + \delta x_{tmp}, \quad (3.29),$$

where

$$\sum_{i=1}^n \delta x_{sens}^i = \sum_{i=1}^n (\delta x_b^i + \delta x_{sc}^i + \delta x_{nl}^i). \quad (3.30)$$

where δx_{res} is the analog to digital converter (ADC) sensitivity correction, δx_{wn} is the white noise correction, δx_g is the correction of the natural acceleration change, δx_{tmp} is the environment temperature correction, δx_b is the axis bias correction,

δx_{sc} is the axis scale factor correction and δx_{nl} is the axis nonlinearity correction. Accordingly, combined standard deviation to the sensor output can be expressed:

$$u(y) = \sqrt{u^2(\bar{a}_i^{sc}) + \sum_{i=1}^n u^2(\delta x_i)}. \quad (3.31)$$

Essential parameters, like terrain roughness, which are calculated using the integration of acceleration measurements to obtain velocity and distance, have cumulative uncertainty over the test time t . Therefore, wherever possible, sensor data fusion should be used using extended Kalman filtration to compensate negative random effects. To estimate vehicle position with good probability, in addition to acceleration sensor measures, other disparate source data can be added to the measurement model. GPS (coordinates, speed, heading), e-compass heading and wheel encoder incremental counts reduce uncertainty considerably [67].

3.6 Conclusions of efficiency metrics

- Focus in this section was on the efficiency metrics that enable evaluation of UGV performance.
- Mobile platforms can be equipped with several power unit types to be treated on an equalized basis.
- Based on the typical vehicle longitudinal dynamics model, a special UGV power consumption model was composed that utilizes resistive forces as key factors.
- Vehicle, track and environment interaction includes several resistive forces that can be subtracted and measured separately.
- UGV internal energy transmission layout and algorithm efficiency can be measured with several ratios to explain the energy losses. A set of efficiency key-parameters was composed that are used for quantifying energy losses during the operation.
- Operational efficiency includes autonomy ratio, reliability and safety, which are not defining the efficiency directly but that must be met when operating.
- Most output efficiency indicators are not measured directly, instead, they depend on several input measures and are altered by a data processor introducing several uncertainty sources to the data acquisition system.

4. EFFICIENCY PROFILES AND DESIGN METHODOLOGY

4.1 Design methodology

In general, all UGV operational inefficiencies during the tasks and missions translate to waste of energy or money. However, it is the usual demand that high efficiency is achieved following safety and emission demands, by handling fragile cargo successfully or fulfilling maintenance interval requirements. The current method helps to evaluate universal mobile platform design, its operational efficiency and estimate its suitability in the field of application.

Main steps of the UGV efficiency validation process are presented in Fig. 4.1. Because of unique requirements for every task and mission, efficiency profile compilation for the platform under study starts by profiling the tasks. Planned field of application is divided to missions, which in turn are divided into tasks whose requirements must be configured as exact as possible to ensure the quality of the result.

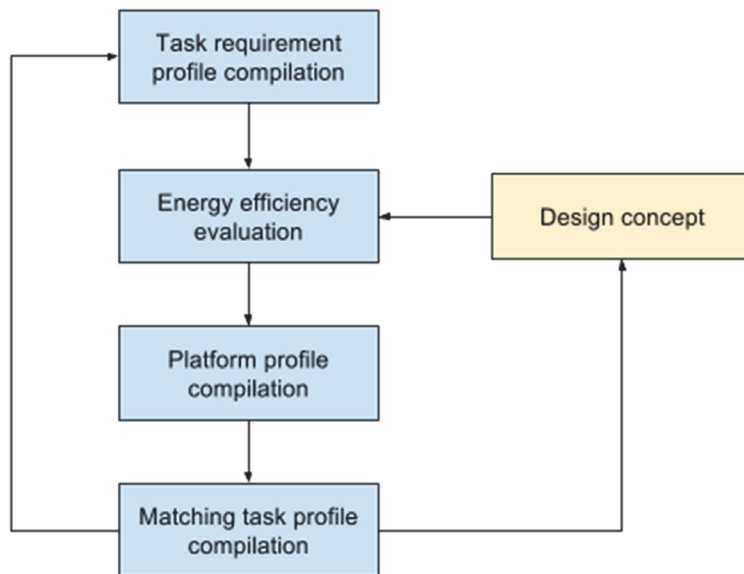

Figure 4.1 Evaluation of mechatronic system design.

To compile the profiles for an UGV design concept, some similar working physical prototypes are required as a design solution candidate. The nature of performance and efficiency measures are as follows:

- quantitative – measured numerically, or
- subjective – evaluated by scoring and rating.

Subjective measures are often used for assessing the quality of operation. Key-parameters are calculated from the dynamic data measured during the real-condition test with the prototype, therefore they are quantitative. The required parameters are divided into three groups:

- dynamic sensor data (Table 4.1) for calculating the key-parameters are measured during the validation test;
- constants (e.g. platform mass) and parameters that change easily predictably (aerodynamic resistance force) are measured on a separate allocated test;
- indexes that are based on counting and classifying incidents (reliability, safety) are obtained statistically over a longer testing period;
- least important parameters can be taken from a database (e. g. weather conditions are based on forecasts).

Table 4.1 Required dynamic measures for calculating key-parameters

no	Measure	Unit	Sensor
1	Processing time	s	GPS unit UTC timestamp
2	Longitudinal acceleration	m/s ²	MEMS inertial sensor
3	Vertical acceleration	m/s ²	MEMS inertial sensor
4	Geographic location	° (decimal)	GPS unit
5	Current consumption	A	Hall effect non-contact sensor
6	Battery voltage	V	microcontroller ADC
7	Track gradient	°	MEMS gyroscope
8	Wheel travelled distance	m	encoder

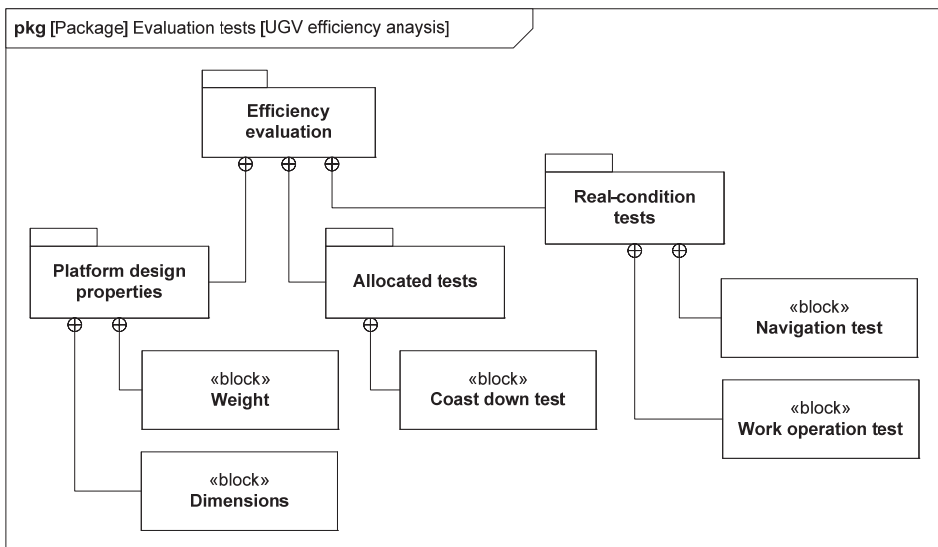

Figure 4.2 Efficiency evaluation tests in the method package.

In addition to real-condition tests, platform's efficiency evaluation includes allocated tests and requires some platform properties (Fig. 4.2) for result calculation. Wheel tire rolling resistance and bodywork aerodynamic drag resistance are measured simultaneously with the allocated coast down test. This can be carried out on several terrains to obtain detailed models. As tire rolling resistance on a particular surface is constant, the corresponding force can be subtracted to find the aerodynamic resistance that grows with the speed square.

Work operation test is carried out to test the drawbar pull limits of the platforms. The force can be measured using a dynamometer sensor between the working tool actuator and the vehicle body. If the coast-down test has revealed the energy requirements for a UGV for moving itself and the full power output is known, it can be estimated. If bulldozing resistive forces become high enough, no useful output remains available and drawbar pull force becomes zero ($F_a = F_p$). It is the case when a vehicle is accelerated to its maximum achievable speed, which is not limited by transmission. In case the drawbar pull force is lower than needed ($F_a < F_p$) for accomplishing a task (snow plowing, obstacle crossing), the traction efficiency η_t decreases the energy efficiency. Then such recommendations to use better gripping tires, caterpillars, mass distribution adjustment, smaller tool (plow) can be given.

Other key-parameters are measured preferably with sensors built into the UGV VMS. The actual instantaneous consumed current during the test is measured using a non-contact current sensor and battery voltage with a microcontroller ADC. To calculate the platform load ratio, the maximum current consumption required is measured with the corresponding test or is taken from the database. It is best to measure track roughness directly from wheels [58]. However, vertical acceleration of the vehicle suspended body has sufficient correlation with general track roughness as our interest is not in exact bump and slope dimensioning. Although the measurement system can be simplified in this way, measurements should still be calibrated with a higher class measurement system as an etalon. Track gradient is measured using an electronic gyroscope sensor included in IMU.

To compare mission and platform profile, efficiency profile of the platform is compiled by evaluating its compliance to the requirements, including the calculation of several efficiency ratios. Thus, all required key-parameters are calculated from the data acquired instead of scoring and judging. This enables automation of the process and an increase in the objectivity. As an automated process that needs minimal effort for test arrangement, it is versatile and easy to evaluate any kind of platform efficiency.

4.2 Energy efficiency profiles of a platform

Platform's efficiency profile will answer the questions about the particular design:

- How much energy is planned into vehicle design?
- How is the energy consumption distributed?
- How efficient is UGV design on given conditions/mission?

- How efficiently does UGV operate during the mission?
- What should be improved in the UGV design to ensure its success and increase its efficiency?

The profile is composed on the data acquired from vehicle-track-environment interaction measurements (Fig. 4.3). Based on the efficiency metrics analysis, the corresponding input measures to create efficiency profile for any moving platform are:

1. energy consumption,
2. power plant load,
3. wheel slip,
4. driving smoothness,
5. calculated navigation efficiency,
6. number of accidents,
7. speed of task processing,
8. useful mass,
9. wear tracking,
10. cost payback period.

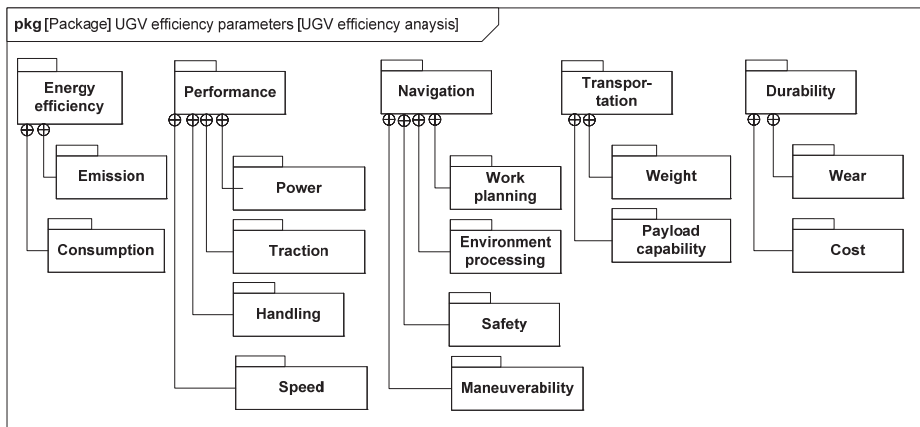

Figure 4.3 Platform efficiency characteristics profile.

Efficiency profile manages and connects the cross-relations of platform design elements and control system specifications with their effects on the performance and energy consumption. The meta-level layout (Fig. 4.5) includes:

- Design models or design specifications sufficiently detailed. For example, a platform has a specific agricultural tire fitted to the wheel.
- Corresponding behaviour parameters. For example, this tire generates high rolling resistance, yet prevents slip until some level.
- Effect on energy and operation efficiency. For example, traction efficiency is acceptable, yet the energy efficiency is too high.

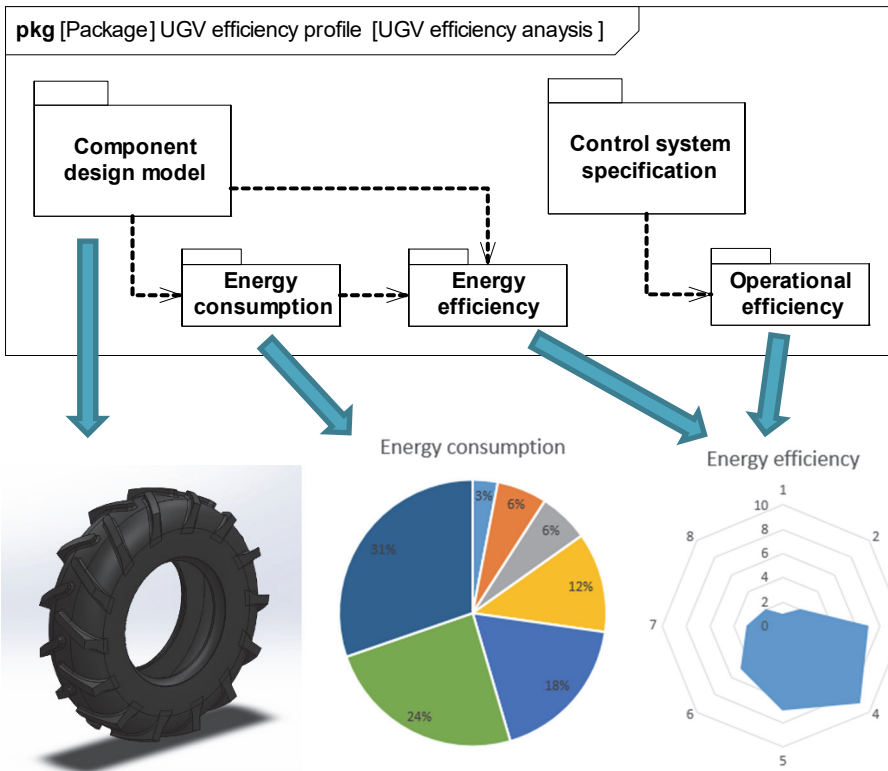

Figure 4.4 Layout of efficiency profile with element examples.

XML based models can be used to make automatic cross linking between elements inside the profiles. The energy consumption of the platform can be visualized with a pie chart with overall consumption divided into parts as losses. Energy efficiency is plotted on the radar chart to illustrate the strengths and weaknesses, while efficiency ratios of different properties are given on several axes, calculated ratios from worst to best in percentages. Based on the results, improvements can be made to the platform design or the entire platform replaced and another cycle of testing processed.

Platform efficiency profile is designed to coincide with the task and mission requirement profiles. Overlapping the task/mission profile with the platform profile indicates the UGV design ability to complete it and suitability in the field of application. If the ratio is 0%, UGV cannot complete the task as its power source is too weak and grip too low. 100% means fully compatible with mission requirements. For example, durability indicator is a property of the platform design. Durable construction is often heavy, simultaneously increasing economy. Lightweight durable materials (e.g. titanium, carbon fibre) increase the cost, which is often unwanted for consumer products.

During the current research, the first input data for profiles were generated by the real-condition tests. To establish data library, the presence of working

prototypes or previous platform versions is required. However, by data acquisition from various platforms in different tasks, in addition to statistically improving the result accuracy, it is possible to synthesize profiles for platforms not yet built in physical form.

Efficiency profiles are also designed to help the consumers choose between universal platforms. While planning a field of application to an UGV, it is not the responsibility of a consumer to start developing and building a new platform design from scratch. Instead, users can acquire profiles from a database or compile profiles themselves to possible platform candidates and make decisions based on the efficiency of a profile about purchase of a solution or to improve an existing one.

4.3 Methodology framework

This research is part of an early design framework research [68] started in 2006 in cooperation with Estonian, Finnish and German research institutions. Optimal key parameter determination at the very beginning of the product design stage reduces significantly the product design cost [69] and helps to develop an optimal conceptual solution for a mobile robot locomotion system. The general concept of the framework is shown in Fig. 4.5.

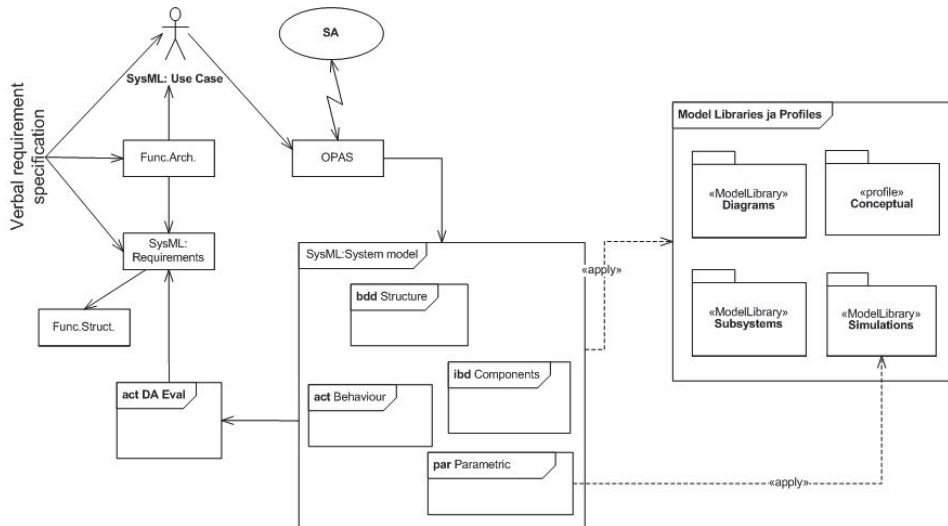

Figure 4.5 Schema of the conceptual design framework [68].

When a UGV is still in its specification phase, a designer and a manufacturer will perform an early evaluation of the requirements baseline before actually buying the physical hardware. Therefore, it is required to have simulation algorithms and a database developed and verified on different types of vehicles, starting from conventional cars to hybrid mobile robots. The results of this research play an important role of verifying those mobile robot simulation algorithms and are used

to develop autonomous navigation scenarios of robotic platforms. The early design framework is providing tools and methods for the conceptual design stage by targeting to qualified and effective results in that stage. The result is a verified and optimal design solution concept reflecting the design requirements and taking into account the different aspects when comparing design candidate solutions.

This thesis research is focused on the performance check part of the design cycle (Fig. 2.1) in order to improve the feedback and re-use of existing designs. As the model is cycled several times, aiding the system design part with libraries and validation, it speeds up the process and an optimal or competitive final product is completed quicker. In addition, a detailed view of platform efficiency parameters is stored in the form of a profile in the database for future development estimations.

4.4 Conclusions of efficiency profiles and design methodology

- UGV operational and energy efficiency profiles and their compilation methodology are described in this section.
- Evaluation method of platform efficiency includes real-condition tests, allocated tests and requires also some platform constants to be calculated.
- All required key-parameters were calculated from acquired data instead of scoring and judging, which enables automation of the process and an increase in the objectivity.
- The platform efficiency profile manages and connects component designs and control system specifications with their effects on performance and energy consumption.
- The platform efficiency profile corresponds to task/mission profile with possible overlapping and represents the index of suitability in the planned conditions.
- This research is a supplement for early design framework research, providing tools, libraries and methods for improving the conceptual design stage of product development.
- Focus is on the performance check and design validation part of the design cycle.

5. EFFICIENCY VALIDATION AND TEST MISSIONS

5.1 Test platforms

This research is targeted to the available mid-size class UGVs, that can be used to accomplish many missions involving transportation, surveillance, maintenance, service, agriculture and other areas. Usually, the most critical factor is energy, which is a limited resource and defines the scope of use and executable missions. UGVs use different and combined energy sources for producing useful work. To treat the platform power plant as one variable in target oriented design optimization, comparison is conducted on equalized basis.

The purpose of a test platform is to accomplish several executable pilot missions in real conditions described by a diagram of high level use case (Fig. 2.2), while the measurement system simultaneously records performance and energy parameters to analyse a vehicle's dynamic energy efficiency. The method enables optimization of the test platform design, as well as development and validation of the energy efficiency profiles for the library elements of a universal design model.

Compilation of the efficiency profile for a given UGV requires a set of dynamic data recorded during a real-time real-condition test mission. The longer the mission and the more varied the conditions, the more accurate results for profiles can be calculated. As missions usually include repetitive tasks, input sensor data analysis methods include data mining and machine learning to compute vehicle efficiency indicators.

During this research, we had an opportunity to test and analyse three different mid-size UGV platforms. All three platforms are similar wheeled platforms with offroad capabilities and a full set of sensors which enable autonomous operation and navigation. They have different ranges of use and capabilities, but they all operate with a relatively low speed (under 40 km/h) and can carry useful load.

The first robot developed in Tallinn University of Technology, Department of Mechatronics is called Uku [70] (Fig. 5.1). This all-terrain-vehicle (ATV) size UGV weighs 250 kg and is an open platform for testing several unmanned technology subsystems. Uku's range of tasks can be snow plowing, street cleaning, surveillance etc. Platform power transmission layout is simple, consisting of planetary gearing in brushed DC motor output and straight bevel gearing without differential on rear axis (Fig. 5.2). The drawback of the design is that as Uku uses only rear wheel drive (RWD) and has light mass on the rear axle, it generates wheel slip easily when driven on loose ground.

Fully electric Uku navigates with the aid of Xsens 3D motion tracker (GPS+INS), SICK 3D laser scanner and a stereo vision camera, rear axle and steering wheel encoders. Manoeuvring backup is provided by a contact type emergency stop system. Electric energy consumption is measured by a non-contact current sensor on the battery output cable and a battery voltage measurement sensor. Xsens motion tracker provides global position system (GPS) coordinates, driving velocity, accelerations and track slopes. Data from the

measurement system are captured with an Uku onboard computer and a wireless transmitter provides data real-time transmission to the operator. Vehicle internal data transmission between electronic modules uses a universal serial bus USB.



Figure 5.1 Electric UGV “Uku”

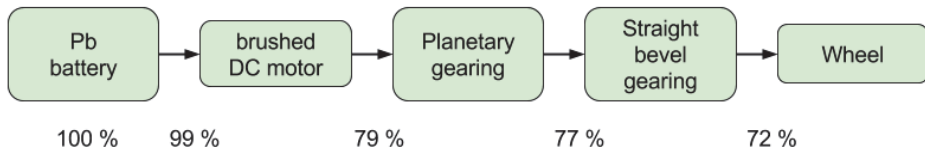

Figure 5.2 UKU's power transmission internal losses.

The second robot platform Tracdron [18] (Fig. 5.3) was developed for Tracdron OÜ by Hecada OÜ in co-operation with the Estonian University of Life Sciences. This vehicle is planned for applications in agricultural activities like automated sampling in cultivated land, unmanned miniloader function and non-chemical pest control on agriculture.

UGV layout is modular, consisting of identical modules that are connected with each other through steering linkage. All wheel drive (AWD) is achieved by routing hydraulics lines to every wheel and body module. This enables connection of two or more modules with dedicated functions or working tools into a self-powered chain. The platform is front frame articulated with differential axles and it has skid steering capabilities as each wheel has its own independent drive. The power unit is a brushless direct current (BLDC) electric motor, but the main hydraulics drive is designed such that a 10 kW diesel engine can be used instead. This allows non-stop operation in agricultural applications where 8 - 10 h charging time of LiFePo4 battery pack would otherwise be a major drawback.



Figure 5.3 Articulated steering hydraulic drive electric UGV Tracdrone and its computer aided design (CAD) model.

Tracdrone navigates with the aid of custom built GPS + INS, each wheel and steering linkage encoders. Higher level obstacle detection uses Leddar inexpensive 3D lidars in the front and back of the body, complemented with ZED stereo-cameras which provide range imaging. Manoeuvring and emergency system backup is provided by ultrasonic distance sensors. Platform's internal electronic modules use controller area network (CAN) for data exchange. The powerful Nvidia Jetson TX1 main computing unit provides 20 Hz constant data output combined from data acquired from CAN modules. Data transmission with the operator is possible over Wifi or 4G network. Electric power consumption is measured by a non-contact current sensor on the battery output cable and a battery voltage measurement sensor.

As the author of the thesis is also responsible for the layout and hardware design of Tracdrone, an opportunity was open to test the efficiency of two main drive layouts and two power units: an electric motor and a diesel engine. The early configuration used (Fig. 5.4a) was as follows:

- 8 cm³ hydraulic pump;
- pump direct drive from the electric motor;
- wheel direct drive from the hydraulic motor.

It was a sufficient configuration for driving tasks 7 – 20 km/h: territory surveillance, soil sampling and other functions with a pulling force ~500 N. For loading and pulling tasks, the hydraulics power unit was too weak and a new configuration (Fig. 5.4b) was included:

- 26 cm³ hydraulic pump;
- 2:1 HTD belt drive between the electric motor and the pump;
- 4.5:1 torque multiplication with 3-stage helical gearboxes on each wheel.

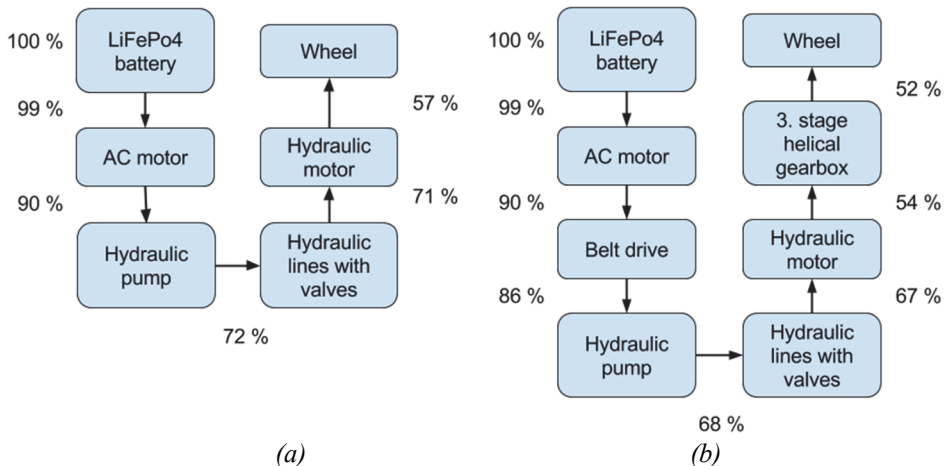

Figure 5.4 Comparison of Tracdron's internal losses: a – early conf.; b – later conf.

As can be seen, upgrading of Tracdron's power transmission introduced also a slight 5% decrease of output efficiency, but enabled an increase in the pulling power over 10000 N level, which exceeds considerably the level tires can transfer to ground. When the electric motor is replaced with 10 kW diesel ICE, the wheel output of a later configuration is expected to decrease as low as 26%. In spite of the much higher energy waste of the diesel engine, UGV range is considerably extended because of high energy density of diesel as well as provision of continuous operation with minimal pauses for refuelling.

In comparison to platforms designed unmanned, ordinary small vehicle can be converted to unmanned. Such UGV developed in Eliko Research Centre is based on Norcar Minkomatic 660 DLA feed truck [71] where driving instruments are automated (fig. 5.5). The purpose of this platform is automated indoor feed transportation. There was opportunity to compare its design against other 2 UGV's and test the profile synthesis possibilities while estimating the performance.

Energy efficiency of the predescribed UGVs was evaluated by the combinations of different energy sources and schematics of power drives (Table 5.1). Although they are all classified as mid-size UGVs, their operating mass differs considerably as Uku is the lightest and Norcar Minkomatic the heaviest. Based on the specifications, it is predicted that Norcar Minkomatic uses more energy than other types due its mass and power source. However, it is constructed for load transportation with the power system built inside the chassis and can simultaneously carry more load while driving less, which means higher mission processing efficiency.

While comparing the internal losses of the platforms, it is clearly seen that more power transmission levels mean higher energy waste. In this sense, Uku shows that simplicity means also higher efficiency (Fig. 5.2). However, it is not always possible to use direct motor drives on wheels to achieve maximum possible efficiency. In the case of Tracdron, in addition to fast body module engaging and water isolation demands, easy power distribution to tools is needed,

which claims the use of hydraulics. It is predicted that because of using a diesel engine and hydrostatic transmission, Norcar would easily prove to be the most inefficient platform, although thanks to diesel high energy density, it is hardly noticed by a user.



Figure 5.5 Norcar based diesel engine powered feed truck.

Table 5.1 Test platform specifications

Platform	Uku	Tracdrome	Norcar Minkomatic 660
Mass	250 kg	400 kg	680 kg
Useful load	120 kg	300 kg	700 kg
Energy source	200 Ah Pb car batteries	132 Ah LiFePo4 batteries	diesel tank 20 l
Drive	4 kw 48 V DC el. motor	3 kW 48 V BLDC el. motor	14,7 kW Kubota diesel
Transmission	mechanical direct	hydrostatic	hydrostatic
Steering	front wheel electric	articulated hydrostatic	front wheel hydrostatic
Powertrain	RWD without differential	AWD hydrostatic	RWD hydrostatic
Turn radius	2,1 m	2,5 m	2,5 m
Wheelbase	1300 mm	1500 mm	1800 mm
Wheel diam. contact width	front: 460 mm, 160 mm rear: 460 mm, 200 mm	all: 780 mm, 190 mm	front: 460 mm, 200 mm rear: 580 mm, 300 mm

5.2 Test missions

UGV design models were validated based on real-condition testing, during which data acquisition takes place simultaneously. Some example missions were created that allow testing the performance and efficiency of available universal UGV platforms. For measuring dynamic performance efficiency, the missions can be split into three parts:

- covering a distance or area – for example, territory surveillance,
- performing a task – for example, loading on/off cargo,
- support functions – measurement system itself, communication, etc.

Mission model requirements for appropriate testing scenarios are:

- feasibility to complete for mid-size wheeled UGV during reasonable time (executable),
- easy repeatability (steady environment condition),
- enabling measurement of all key-parameters (not isolated).

During the current research, three mission scenarios were studied:

- snow plowing on a car lot,
- territory surveillance on a closed area,
- livestock feed transport.

Snow plowing mission (Fig. 5.6) is the easiest for an UGV to complete as the autonomy level required is quite basic. This mission is suitable for Tracdron. The area is defined by GPS coordinates, on the basis of which UGV calculates its plowing pattern and adjusts it based on obstacle encountering (cars, street light posts). The main challenge is to maintain traction by not collecting too much snow in front of the plow that would overcome UGV drawbar pull capacity.

During the mission, the platform control system solves several automated tasks:

- tracks its position and energy amount,
- avoids obstacles while driving around,
- calculates the most optimal navigation route to cover the whole area,
- prevents the UGV for being stuck with driving wheels slipping,

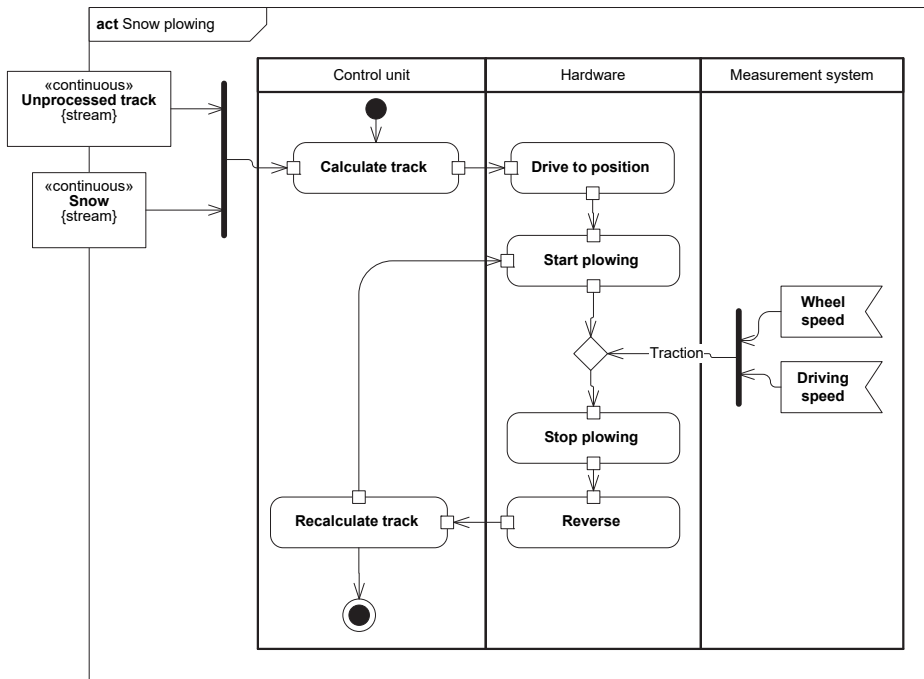

Figure 5.6 Snow plowing action diagram.

Territory surveillance mission is described here as a mission suitable to accomplish for all three test platforms for comparison purposes (Fig. 5.7), although very suitable for UKU. The mission involves covering a distance between waypoints, while the driving route between them is unspecified - UGV navigation system can choose a path that suits it and is easier to pass through. The patrol route is closed, UGV reaches back to the control point. The terrain is diverse, including gravel, loose sand, grass, meadow. Obstacles are mostly trees, stones, fallen tree branches, trenches etc. Testing platforms carry no payload, they only scan the surrounding environment while driving autonomously. It is required for the defined scenario to take action when movement is detected, i.e. find the intruders heading and send photos of an intruder to the control centre while staying on distance itself. UGV intruder detecting capability means it detects moving objects (humans, animals, other vehicles) using stereo camera image processing.

During the mission, the platform VMS solves several automated tasks:

- tracks its position and energy amount,
- detects moving intruders and takes actions,
- avoids obstacles while driving around,
- prevents the UGV for being stuck,
- calculates the optimal (shortest) course length to travel between waypoints,
- adjusts the route based on the vehicle and environment condition.

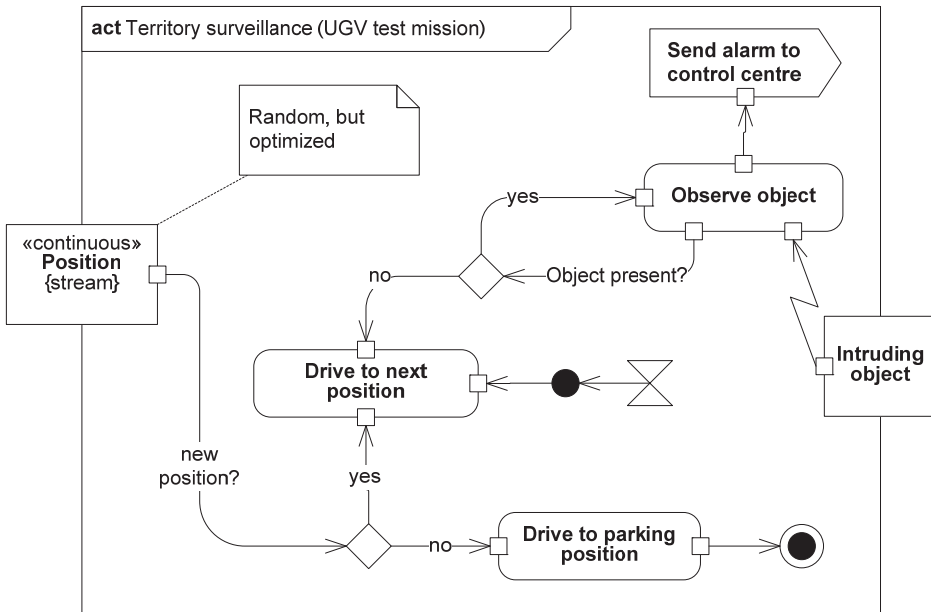

Figure 5.7 Territory surveillance action diagram.

Feed transporting mission is the most complex mission; it was planned for the Norcar unmanned transport vehicle as it has a suitable transportation capacity. It is a hybrid mission as it includes all types of tasks (Fig. 5.8). The loader mission is used for livestock automated feeding in large farms. The mission starts at a certain time when the loader drives to a separate stock building, to fill its container with the feed in the storage point. Then it drives through the yard to the first livestock building with the aid of GPS + INS and a lidar. Navigation inside the buildings is aided with wireless radio beacons where at least three beacons are always reachable. If the loader reaches the feed vessel, it fills it with the predefined amount of feed. This takes a certain amount of time and consumes energy. After that, the loader navigates out of the building and through the yard to the next livestock building. If the loader detects an empty feed container, it drives back to the storage point for more supply. Similarly, if a low diesel fuel amount is detected, the loader drives to the automatic refueling station. The loader continues the mission until all the feeding vessels in all farm buildings are filled to a certain amount. Then it drives to its parking point and waits for the next livestock feeding time. Human intervention is only needed in case of unexpected failures and technical maintenance of loader systems.

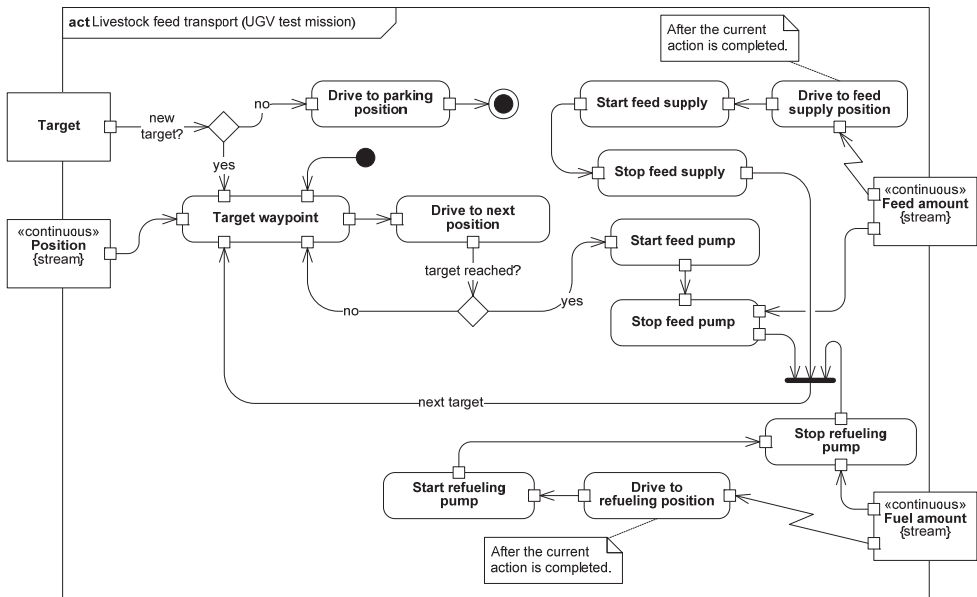

Figure 5.8 Activity diagram of livestock feed transport mission for an UGV.

During the mission, the loader control system solves several automated tasks:

- tracks its position, fuel amount, container content, work completion,
- performs automated cargo on/off loading tasks,
- avoids obstacles while driving around,
- prevents the UGV for being stuck,
- calculates the optimal (shortest) course length to travel in the farm area,
- adjusts the route based on the loader and environment condition.

The described example missions enable measurement of all fundamental energy efficiency parts and the measurement result will provide information for the following design questions:

- Is the platform design suitable for the current mission?
- How effective is the navigation control system in real-condition environment?
- How much time and fuel is saved or wasted compared to human teleoperated driving?

5.3 Validation testing

Real-condition testing was carried out with universal UGV platforms Uku and Tracdroner to validate their performance, operational efficiency and suitability for planned test missions (Figs. 5.9 – 5.10). Sensors needed were added to the platform VMS when not present and there was no need to install separate data logger electronics. On both platforms, VMS was modified to output the necessary raw sensor data wirelessly with constant frequency 20 Hz.



Figure 5.9 Tracdroner during the real-condition testing.



Figure 5.10 UKU during the real-condition testing.

Basically, all three mission types are driving missions where the UGV has to accomplish a task by reaching from one location to another. There were no

difficult navigation or working operations included that would considerably affect the result of the mission. Territory surveillance mission was conducted with both platforms as well as with elements of the snow plowing mission. Feed transportation mission is suitable for Norcar only as currently other platforms have no suitably large containers in their equipment. Testing was carried out on steady terrain conditions in an industrial area with relatively good conditions.

Some constant parameters needed for collection of efficiency profiles were measured with an allocated test or calculated according to method and are presented in Table 5.2. Air temperature and density, wind speed and direction were assumed from the weather forecast. It is required to weight platforms with vehicle weighing devices or at least calculated from the CAD model. In the current project, mean masses were estimated from models.

Table 5.2 Input constants of the test platform profile

Platform	Uku	Tracdron
Mass	250 kg	400 kg
Tire rolling resistance	0,23	0,25
Body cross section	0,54 m ²	0,73 m ²
Drag coefficient	0,38	0,37

To evaluate tire rolling resistance and the aerodynamic drag of the platforms, an isolated test is required. The coast down method from the speed 40 km/h is most practical. As both platforms rigidly drove without clutches to avoid use of separate brakes, they had to be modified by disconnecting driving motors. A car was used to tow it up to speed 40 km/h and let it rolling freely while platform sensors measure the deceleration (Fig. 5.12). At such speed, the aerodynamic effect is still small and offroad UGV is anyway not operated at higher speeds. As the rolling resistance force grows linearly with the vehicle speed, the non-linear component in the coast down test graph can be used to estimate the bodywork aerodynamics. Depending on the bodywork, it starts to add resistance force over 20 km/h and grows exponentially. To calculate the drag coefficient, the vehicle front area was estimated with a counting mesh (Fig. 5.11).

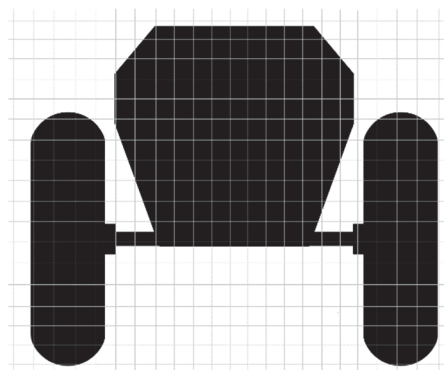

Figure 5.11 Drag area estimation of Tracdron.

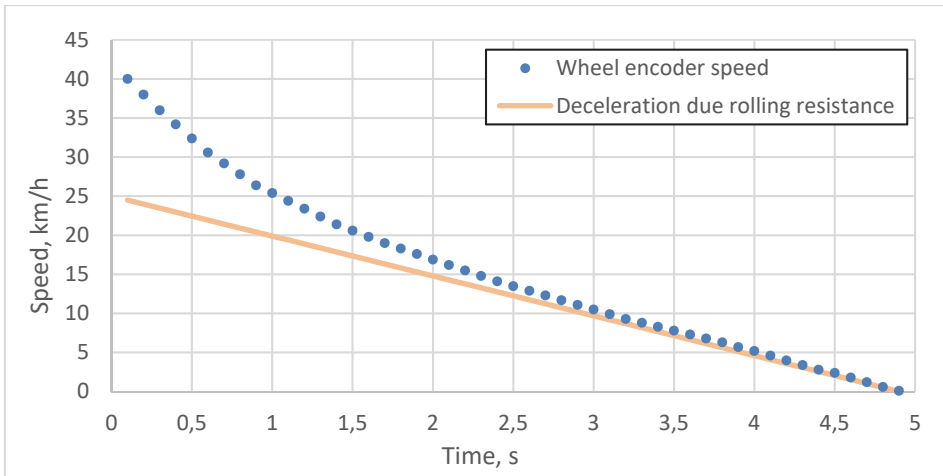

Figure 5.12 Coast-down test of Tracdrone.

Rolling resistance coefficient was calculated according to formula (3.2) based on the measurement of the resistance force. By subtracting the rolling resistance, the aerodynamic drag can be estimated with formula (3.3).

As the Tracdrone is capable of basic detection of obstacles using the low resolution 3D lidar, its navigation efficiency can be measured. It was required to drive autonomously around square base of the facility using corner detection (Fig. 5.13). As seen on the recorded GPS track (red line in Fig. 5.14), it is most difficult to pass the corner that stays away from lidar range of view. It must count on the dead reckoning algorithm to manoeuvre over the corner and find the wall again. The facility base dimensions were measured and GPS coordinates of ideal trajectory were plotted. Mean deviation of the recorded track from an ideal trajectory (yellow line) was 1,2 m and UGV covered 156 m, 12 m longer than ideally. Also, the task took 4:50 min more to complete than driving smoothly (1:15). In general, it means navigational efficiency $\eta_n = 92\%$ using formula (3.13) and operational efficiency 28%. As this is only one task, the overall navigation efficiency of the mission could be lower.

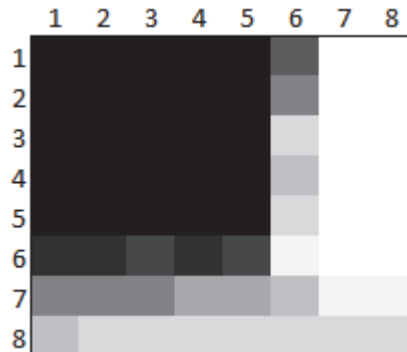

Figure 5.13 Facility corner detection with low resolution 3D lidar on Tracdrone.

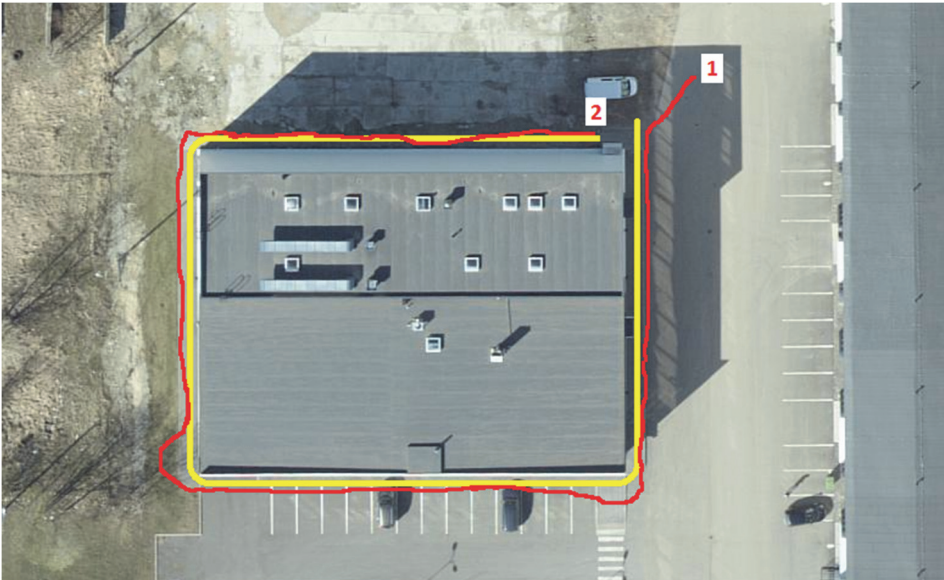

Figure 5.14 Navigation efficiency test of Tracdron (1 – start, 2 – stop).

Territory surveillance mission consisted of driving the defined route using GPS while observing the surrounding environment. Figure 5.15 shows the recorded route around the defined guarded area accomplished with Tracdron.



Figure 5.15 GPS recorded route around the defined guarded area on the territory surveillance test with Tracdron (1 – start, 2 – stop, 3 - pause).

In the context of this mission, close following of an ideal route, high driving speed or short route duration is unimportant. Instead, energy efficient smooth driving to lengthen the range and the possibility to find intruders with imaging devices are required. If the UGV navigation system forecasts all collisions and stops early enough, then minimum breaks are required and all decelerations can be done with regenerative braking, which increases energy efficiency. Driving smoothness is described by the curvature, time to collision and mean acceleration. As the turning radius of platforms is known, the easiest way to measure the curve radius is to record steering wheel encoder (Uku) or central joint hydraulic cylinders positions (Tracdron). Time to collision relies on the 3D lidar range measurements to detect obstacles. Mean absolute value of driving direction acceleration describes the overall driving smoothness.

UGV was driven with varied speed, depending on the road conditions. The graph shows a short pause when the vehicle was stopped (Fig. 5.16). Every breaking and reversing action decreases the efficiency – the vehicle has to be accelerated to the travelling speed again. The resulting energy consumption per distance is plotted in Fig. 5.17. It is obvious that light vehicles have an advantage as the mission specification requires no power and the circumstances are good. While the vehicle is stopped, electric motors have a clear energy consumption advantage as ICE uses additional fuel energy for idling the engine.

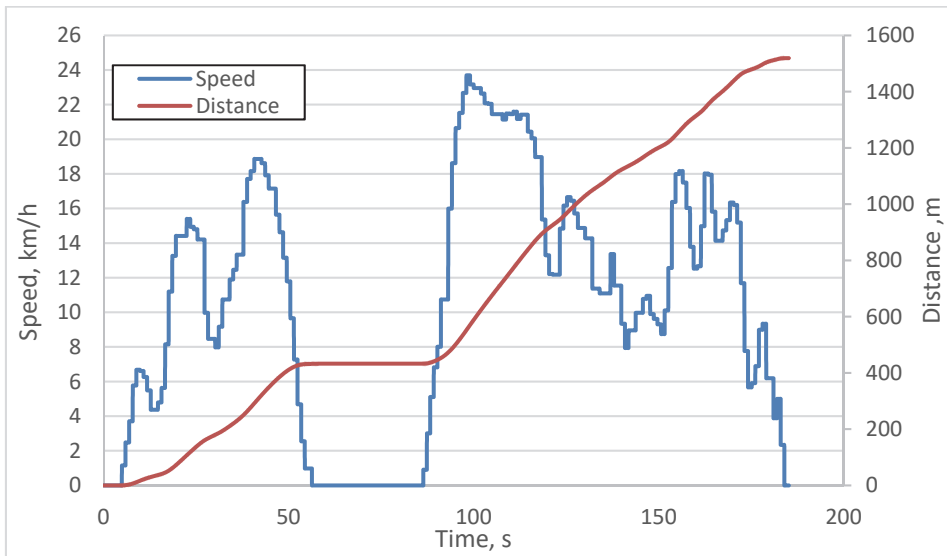

Figure 5.16 Tracdron's GPS speed and distance during the territory surveillance test.

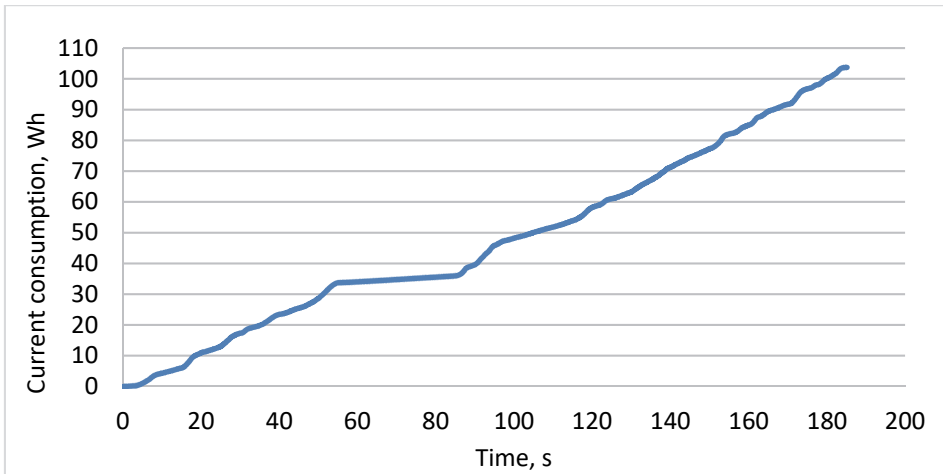

Figure 5.17 Tracdron's accumulated current consumption during the test.

A similar mission was carried out with Uku on a forest track (Fig. 5.18). As lighter vehicle consumes less energy for driving (Fig. 5.19), territory surveillance has much higher energy efficiency while conducted with a small UGV. To compare both of the tracks, their roughness index should also be calculated using the vertical acceleration recordings of the vehicle body. Although Uku has suspended chassis unlike Tracdron, body movement correlates well with track bumps and slopes. In Tracdron gravel and rough asphalt track, mean roughness was 2.5 mm/m while the forest track for Uku had 4 mm/m. For low driving speeds < 20 km/h, speed correction is not needed [25].



Figure 5.18 Uku GPS route during the territory surveillance test in the forest (1 – start, 2 – stop).

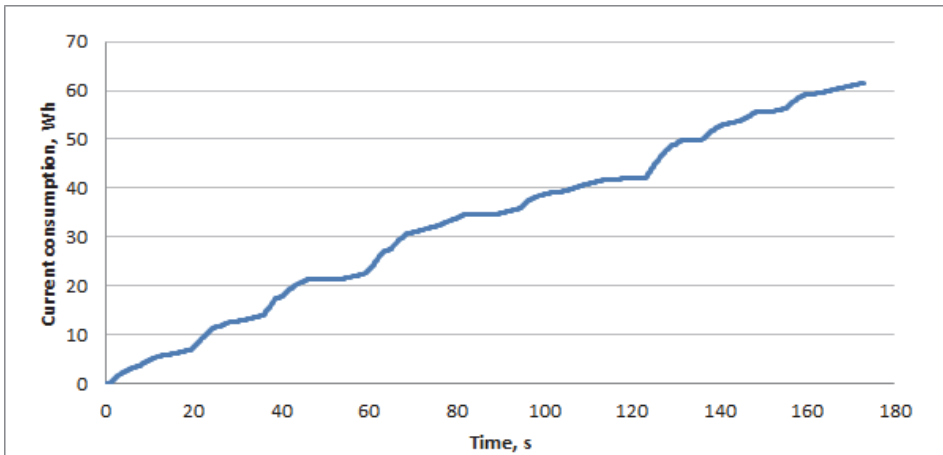

Figure 5.19 Uku's accumulated current consumption during the test.

Uku and Tracdrone consume current in relation to driving differently. As Uku's electric motor is directly connected to the rear axle, current consumption is highly correlated to the vehicle speed. Although Tracdrone's current consumption during the test shows rough correlation with the electric motor speed (Fig. 5.20), it is only correlated to the electric motor speed and load – hydraulics pressure, which is in turn dynamically adjustable with a stepper and pressure regulator. Actuating turning cylinders while a vehicle is stopped requires almost 15 MPa pressure, which requires 76 A current flow from the battery. Pressure drops to 2 MPa – 3 MPa while driving, caused by the wheel motor's high throughput, which consumes only 10 A – 15 A current. It should be noted that that the pump motor is only driven at speeds over 23% because it is unstable under that level.

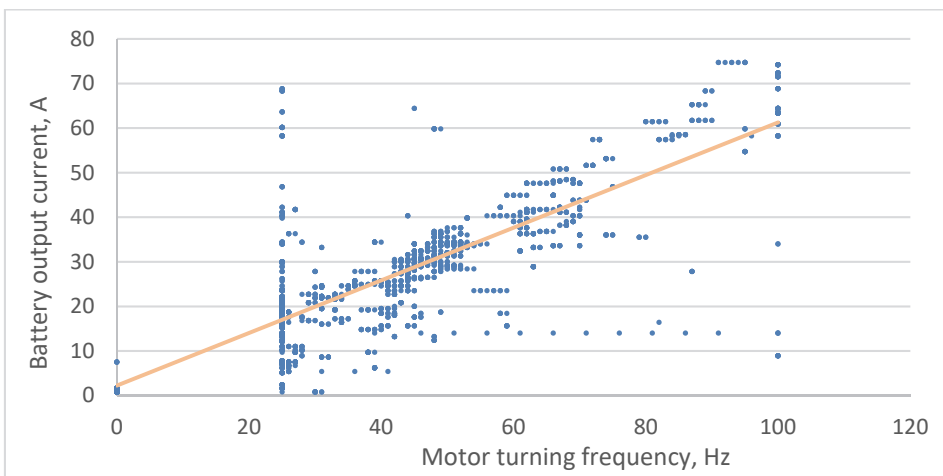

Figure 5.20 Tracdrone's current consumption correlation with the motor speed.

Drawbar pull does not affect the efficiency in the context of the current mission, as platforms are only moving their own mass. Still, based on the resistive force

measurements before and during the field test, the summary specific resistive forces can be calculated to platforms by reducing the track to the flat ground and plotting in relation to the driving speed:

$$F_n = F_d + F_r - F_g. \quad (5.1)$$

As can be seen on the graph (Fig. 5.21), when the platform reaches its speed limit because of resistive forces, the motor is not capable of accelerating it further since no more useful force is available. Due to the offroad design, wear is expected to increase exponentially on tires and transmission; therefore, the platform has its most efficient range of use at low speeds (> 15 km/h).

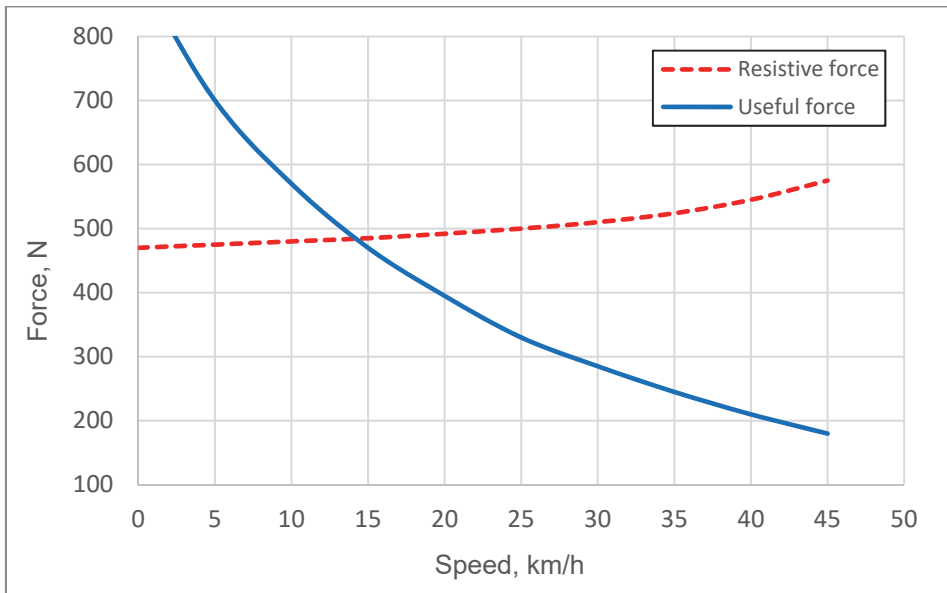

Figure 5.21 Resistive force and useful force calculated for Tracdroner driving on flat terrain.

In addition to the mobility efficiency characteristics of platform calculated based on dynamic measures, other efficiency properties can be calculated based on real-condition tests. Statistical reliability accidents of Tracdroner's territory surveillance mission included:

- loosening bolts in the central joint after driving 1 km, which eventually lead to breakdown as the platform was unable to steer anymore;
- oil leak occurrence noted after driving 1 km as the movement loosened the line attachment nut.

Uku had driving electronics problems, so it had to make unintentional pauses several times during the test, yielding about 30% operational efficiency. Wear tracking of both platforms needs long-term operations as the effect is not

measurable during some episodic missions. Correct information about reliability and wear can be obtained when a UGV's work on long-term and daily basis with data recording devices installed.

5.4 Compilation of efficiency profiles

Real-condition testing generates large sets of data for analysing the platform design properties. The recorded test data enabled calculation of several specific parameters for the efficiency profile, observed in the efficiency metrics analysis. Parameters from the territory surveillance mission are given in Table 5.3.

Table 5.3 Calculated parameters for platform profiles

Parameter mean value	“Uku”	“Tracdron”
Current consumption, Wh/m	4,5	8,2
Auxiliary power consumption, Wh/m	0,8	0,7
Driving speed, km/h	7,4	11,3
Longitudinal acceleration, m/s ²	0,5	0,8
Longitudinal deceleration, m/s ²	0,5	0,9
Distance from obstacles, m	3	2
Time to collision, s	1,4	0,7
Curvature, 1/m	0,2	0,4
Terrain roughness, mm/m	4	2,5
Ratio, %		
Load factor	57	41
Traction efficiency	61	96
Tractive efficiency	72	52
Navigation efficiency	85	92
Operational efficiency	33	28
Reliability	30	30
Autonomy	50	50

As testing Norcar in real-condition test was not possible, its efficiency map can be predicted based on similarities with other two platforms. Conditions for Norcar feed transportation mission are easy to measure. This makes possible to estimate some efficiency parameters for Norcar profile based on its technical data (Table 5.1) and through scaling based on other tested UGV platform data (Fig. 5.22). Besides being heavier, Norcar has the following layout properties:

- similar to Uku – front wheel steering;
- similar to Tracdron – hydrostatic power transmission;
- different from others – diesel engine, large transportation capability;

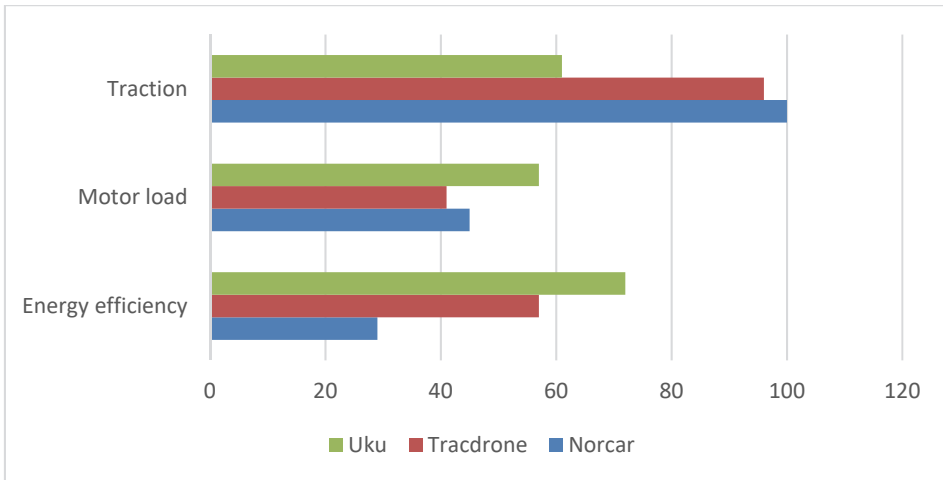

Figure 5.22 Comparison of efficiency parameters of unmanned platforms

Platform efficiency ratios were calculated for testing data according to metrics described in section 3. For example, Tracdroner’s load factor calculation during driving is based on formula 3.6 and it uses the current consumption sensor on the battery output cable. It was found that a full load on a 3 kW electric motor consumes 86 A current constantly and maximum values are experienced on accelerating the wheel motors while driving at constant velocity consumes relatively low current (Fig. 5.22). The average load factor $\eta_L = 41\%$ means that Tracdroner can easily accomplish pure driving tasks like territory surveillance mission. For lowering the energy consumption, it is possible to use ~1.5 kW electric motor with an expected load ratio of 80% – 90% although it means pulling or climbing is not possible anymore.

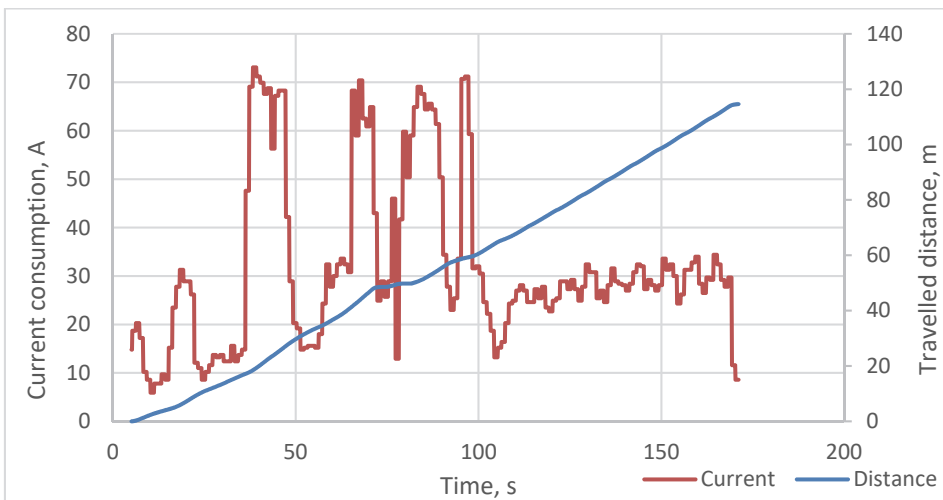

Figure 5.22 Data recording section for load factor calculation.

Using efficiency profile visualization, better feedback to the studied platform design and operational suitability can be given. Efficiency maps in the form of a radar chart for all three platforms are presented in Fig. 5.23. The corresponding mission maps according to task requirements are in Fig. 5.24. The map plots the summary efficiency ratio of the platforms and divides the energy losses by type. Although all platforms are universal, their properties and capabilities are different. In a similar way, mission layouts and requirements need particular UGV properties for processing with maximum efficiency. If the mission profile area fits into the platform profile area, the platform can meet all the mission requirements. However, considerably larger platform capability margin indicates poor energy efficiency as its strength reserves are exaggerated.

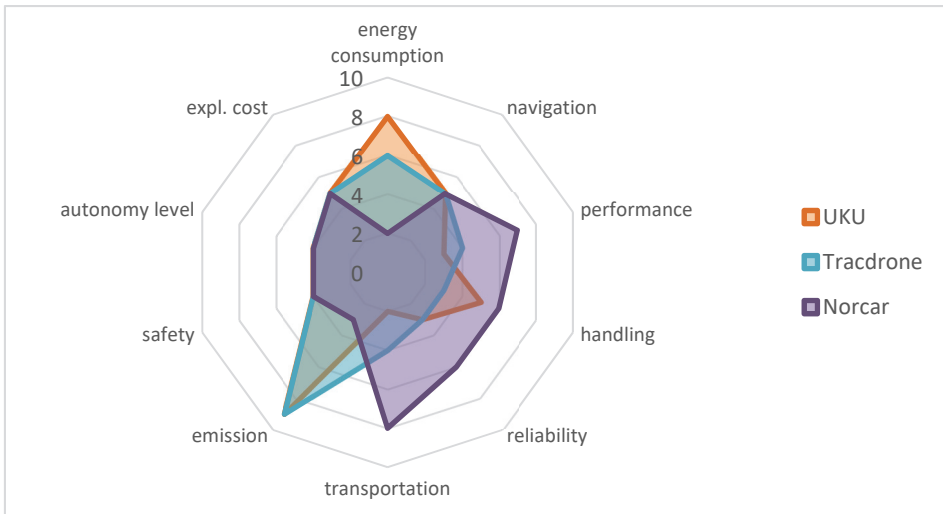

Figure 5.23 Calculated efficiency ratios for test platforms.

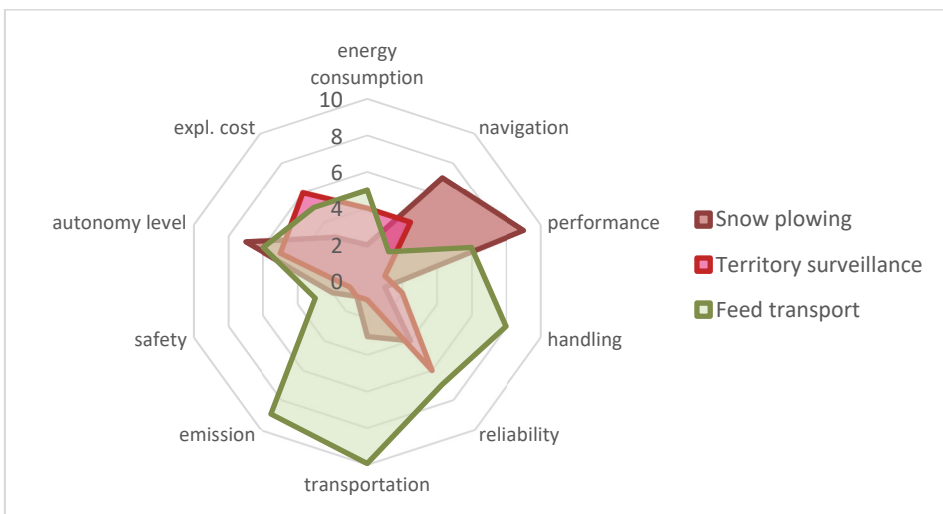

Figure 5.24 Requirement map for test missions.

Due to allocated coast down tests, it is possible to divide the energy consumption of both platforms into parts. The contribution of resistive forces of the Tracdron UGV during the test mission is summarized in Fig. 5.25. As can be seen, most of the energy is consumed for accelerating the platform to a speed and overcoming slopes. Uku was driven on different road conditions (Fig. 5.26). While the speed was lower on offroad conditions, its energy consumption increased by about 20%. Also, offroad required more power to accelerate the vehicle due to frequent slopes and high terrain roughness. Aerodynamic drag effect was expected to be negligible on all platforms as they are similarly low speed operated.

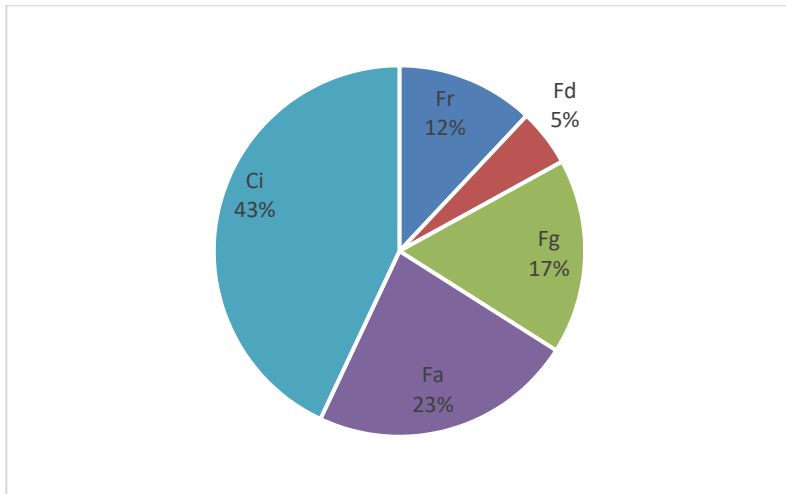

Figure 5.25 Distribution of resistive forces during the Tracdron test.

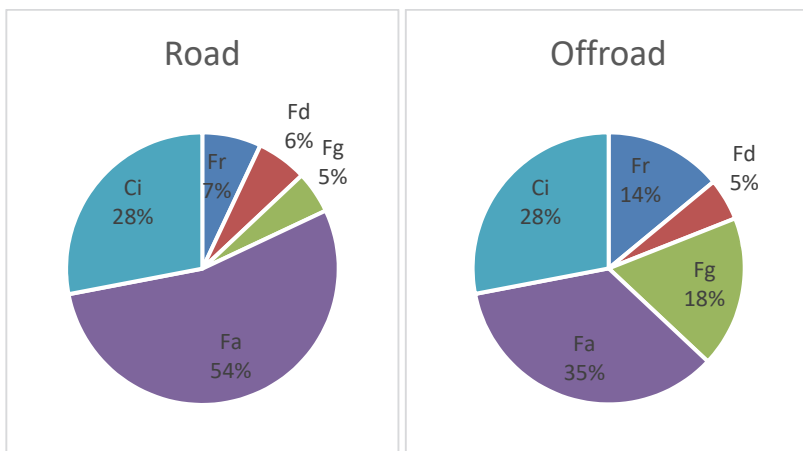

Figure 5.26 Distribution of resistive forces of Uku in two different tracks.

At consumer purchase price, all three platforms are estimated to be on same price level (about 16 000€), depending on the sensors used, 3D laser scanners are best for navigation but very expensive. Routine and maintenance costs are expected

to be in the same level with the ATV vehicle (about 100€ per month). Therefore, if the same missions are processed by a human worker on workdays, UGV profitability will show better at operating under a year. If non-stop 24 h work is planned for UGV, it will pay back its costs within some months of the operation time.

However, there is always a possibility to lower the UGV purchase price and increase cost-efficiency by using cheaper technologies, materials, components that satisfy the requirements. It is the usual case that a prototype is much more expensive than a serial product. Still, at some point, reliability starts to deteriorate when the cost influences the quality too much. Exploitation costs are much lower on electric vehicles because charging the battery is inexpensive and there is no need to change oils, filters etc.

5.5 Validation results

Based on the data acquired from the allocated and the real-condition testing, efficiency profiles were compiled. Profiles enable us to validate the platform suitability for processing the planned test missions. Using the composed profiles, the following conclusions were reached:

- Real-condition testing validates the field of application of the UGV under study. None of the current platforms were developed for the territory surveillance mission; however, light vehicles like Uku will suit best for this range of use. Tracdrone seems suited for snow plowing and bulk material loading tasks. Feed transport mission is clearly inclined to favour high cargo capacity, therefore most suitable for Norcar.
- Electric power unit equipped vehicles have best energy efficiency and emission properties. However, due to high energy density and non-stop operational capabilities, ICE powered platform has much better operational efficiency since it can produce more useful work with the same time.
- Navigation efficiency and autonomy level of an UGV can be measured numerically and used for technology limit comparison in the current state of development. So far most studies rely on subjective scoring. Depending on the mission, demands for autonomy level are different with varied conditions that need much higher level of adaptivity.
- Tracdrone and Uku consume current differently due to the power distribution system. Although a hydraulics system has its advantages, it consumes about 20% more energy than the direct drive for accomplishing the same task. It is also seen that modifying the Tracdrone's power unit yielded to 5% more energy consumed for driving. This is not a rational improvement for territory surveillance but it increases performance considerably for a snow plowing task.
- Based on the predefined constants and the data measured during the real-condition test, resistive forces during the UGV movement were calculated and energy efficiency distribution plotted. This reveals that

most of the energy is spent on overcoming rolling resistance, aerodynamic resistance is negligible at those speeds.

- Several improvements to platforms can be suggested by platform efficiency profiles. All platforms should be fitted lower rolling resistance tires as terrain is quite easy. UKU could benefit from powertrain development and differential transmission. Tracdron articulated steering design and hydraulic powertrain is not for smooth handling on long driving. Norcar is too heavy and possibly wastes too much energy for the observed application.

5.6 Conclusions of efficiency validation and test missions

- Efficiency validation of several UGV platforms was described in this section.
- During the thesis research, there was a possibility to analyse the efficiency of three different wheeled mid-size UGV universal platforms.
- Three mission scenarios are proposed for the testing performance of the platforms. Each requires different qualities in order to be solved successfully.
- The allocated coast down testing enables us to indicate the distribution of resistive forces on the energy efficiency profile.
- Navigation test indicates the platform navigational efficiency, as well as the autonomy level and reliability.
- Drawbar pull force measurement indicates the power and traction limits of the platforms.
- Energy efficiency profile plots the summarized ratio of the UGV operational and energy efficiency as well as individual property ratios.

CONCLUSIONS

The aim of this research was to develop a method for evaluating energy and operational efficiency of a mobile platform based on the requirements set by the field of application. The current work contributes to the standardized performance evaluation of autonomous platforms. As the efficiency profile compilation is based on the calculations, not subjective scoring and judging, the results reflect the properties of the platform more closely. Based on the real-condition results and the design validation of the current platform, assumptions and estimations can be made for other new platforms that are in an early design stage.

The primary result of the work is the method for compiling a task and platform efficiency profiles based on the real-condition testing results.

In the research, several steps were performed in order to create the methodology:

- Typical UGV tasks and missions were observed to find the essential key-properties and assign priorities. It is necessary for a platform to meet these task requirements for successful operation.
- Based on the typical longitudinal dynamics model of a vehicle, a special UGV power consumption model was composed that utilizes resistive forces as key factors. Energy and operational losses were described using several ratios included to the internal and external energy conversion.
- The energy efficiency key-parameters were examined based on three available mid-size UGVs. Though test vehicles are using different power sources, transmissions and steering principles, their design is compared on equalized basis.
- Platform design and operation were tested in real-conditions to obtain dynamic data for validation. Some parameters were measured directly during the test with a self-contained measurement system, other parameters were calculated during the allocated test or obtained statistically over a longer testing period.
- Energy and operational efficiency profiles were compiled. Although accelerating and resistive forces can be measured together, it is not enough to know the summary values. Instead, the design analysis requires separation of the applicable forces and separate descriptions.

The main objectives were completed in the following levels:

- Efficient operation properties of tasks and missions assigned to universal mobile platforms were analysed. Requirements for efficiency were established based on the task map that describes and limits success factors. Priorities were assigned by scaling the parameters in comparison with each other. Standardized requirement profiles are easily linked with mobile platform design elements. Task requirements will not restrict the principles of the platform design element. Instead, they set up successful

operation criteria. Exact task profile helps to search an ideal platform design that completes the task with maximum efficiency.

- A method for testing the key parameters of the mobile platform efficiency was developed. The method includes several tests for obtaining the key parameters of efficiency. Efficiency analysis was based on the energy consumption model, specially composed for mobile platforms that use its power source to generate useful physical work during task processing. A set of efficiency key-parameters was used for extracting and quantifying energy losses during the operation. Thus, it is possible to measure every platform efficiency property required by a task.
- The layout and compilation of the efficiency profile is presented. The efficiency profile for a particular mobile platform describes its performance, current design strengths and weaknesses, energy consumption distribution and sources of inefficiencies. An efficiency map was composed using several appropriate ratios calculated from the dynamic data of real-condition testing. Platform profile layout was designed to correspond to the task map layout for easy assessment of design suitability in the field of application. By overlapping them with mission requirement profiles, suggestions for design improvements were compared.
- The validation results of existing platforms were used in product development for improving the early design phase. Based on the recorded data during several tasks, efficiency profiles were created and compared with mission maps. The results can be organized in knowledge library and used for an engineering toolkit which allows easy platform design validation, aiding simulations, predicting design concept performance and efficiency.

Contributions of the research:

- A contribution is made to the standardized performance evaluation of autonomous platforms. Although it is currently uncommon, consumer benefit is clear when getting objective benchmarks.
- Compilation of the energy efficiency profile of the mobile platform and assessment of a single component effect on it. Validated and accurate energy efficiency information and derived design guidelines provide major improvements in the optimization of an unmanned ground vehicle platform.
- Improvements in the early design phase of unmanned mobile platform development. Consumer market for mid-size unmanned platforms is expected to grow exponentially, accompanied by an increasing demand and a stronger need for handling the complex design process. As energy efficiency is always one of the most important measures in consumer products, it is especially important to support it in the early stage of a design process.

- It is demonstrated that designing energy efficient and versatile platforms is a current trend. As robot platforms are often designed universal, design requirements consider multiple aspects that make optimizing energy efficiency and meeting requirements complex.

Novelty of the research

The scientific novelty of the research involves:

- Compilation of task and mission properties into standardized requirement profiles, which is easily linked with mobile platform design elements.
- Proposal of energy consumption model specially composed for mobile platforms that use its power source to generate useful physical work during task processing.
- Composition of the mobile platform efficiency map that describes its design strengths and weaknesses numerically. For this purpose, several appropriate ratios calculated from dynamic data of real-condition testing were used.
- Suitability assessment of mobile platform design in the field of application using composed efficiency profiles overlap with mission requirement profiles.
- Provision of comparative test of two universal platforms as a guideline for further applications.

Future work

The main limitation for testing is the lack of available UGVs in usable condition. As the field of unmanned technology is still new, only few platforms in the vicinity are under development and available for testing. It was very helpful that the author's own project Tracdron and Uku were available in the university when needed. Hopefully, more platforms can be tested in the future.

Low level of autonomy of unmanned platforms limited testing complexity. As they were prototypes under development, navigation and adaption with environment conditions was rather basic and hard to test full operational efficiency in real environment. Advanced autonomy can also be tested further

As the estimations of platform properties rely on statistical analysis, clearly more testing data are needed to improve the system. The more data are recorded during real-condition testing, the less uncertainty of the profile indicators will there be. Because of large data amounts, utilization of data mining and machine learning algorithms is essential for result computing.

It would be beneficial to test all three platforms in several missions that have different requirements. Varying the environment conditions and different terrains is also important. Other platforms, especially those using different locomotion and steering mechanisms or power conversion chain, should be tested when available.

Both platforms used for real-condition testing are currently on the prototype level with plans to develop the design further. Therefore, both benefit from compiled energy efficiency profiles, which are basically a collection of relevant properties and their effects, to match better with a planned field of application. Tracdrone's first application is agricultural soil survey and sampling, which creates the need for extending the operation time and distance by improving the navigation and energy efficiency while preserving the performance characteristics.

In addition, the results are used for validation of simulations; a database of the testing results for several mobile platforms can be used to predict the results when similar solutions are under development. Currently, no databases are freely available, for example, those containing data of rolling resistances of different sufficiently described tires. Although there are simulation and estimation methods available for early design support, a comparative database would enhance the energy efficiency forecasting considerably. More precise input to simulations yields to a better output.

To improve practical usability of the method, automatic compilation of the efficiency profiles simplifies acquisition of the results, comparison of different platforms and their properties. XML based design models enable automatic cross-linking between different profiles. While new information is uploaded, the system would benefit from self-training algorithms. Therefore, corresponding software should be developed which would process recorded testing data.

The solution could become a valuable part of an online knowledge base [72] that combines information and tools to aid the design process of mobile robotics. The components already configured and validated would be freely available. In addition, the common knowledge sharing environment activates co-operation between SMEs and research institutes. The essential parts in the knowledge base would be:

- efficiency profiles of existing platforms;
- configurable requirement profiles of typical tasks;
- platform performance analysis and comparison tool;
- detailed design configurator for generating platform layouts to match requirements;
- energy efficiency estimation of platform layout.

The next level of efficiency evaluation is to study co-operation of multiple UGVs or co-operation with UAV that is already in the area of interest [44]. Tasks can be divided between platforms with different capabilities and therefore improve mission processing more than possible with independent platforms. Currently, most UGVs are used independently as they lack sufficient intelligence and adaptivity to co-operate. However, this will certainly change in the near future with the growing market.

REFERENCES

1. Unmanned ground vehicles (UGV) market by application (defense, commercial), mode of operation, size, mobility, payload, and region (North America, Europe, Asia-Pacific, Middle East, rest of the world) - global forecasts to 2020 [WWW] <http://www.marketsandmarkets.com/Market-Reports/unmanned-ground-vehicles-market-72041795.html> (13.09.2016)
2. Global mobile defense rescue & security robots – sensors & payloads: markets & technologies outlook – 2012-2017 [WWW] <http://marketinfogroup.com/non-military-sensor-dense-unmanned-ground-vehicles-military-ugv-market/> (20.09.2016)
3. Seekur Jr [WWW] <http://www.mobilerobots.com/researchrobots/SeekurJr.aspx> (20.09.2016)
4. Pegasus: Multiscope [WWW] <http://www.businesswire.com/news/home/20160613005624/en/Milrem-Leica-Geosystems-Announce-PegasusMultiscope-Unmanned-Ground> (20.09.2016)
5. Nie, C., Assaliyski, M., Spenko, M. Design and experimental characterization of an omnidirectional unmanned ground vehicle for unstructured terrain. *Robotica*, 2015, 33, 1984-2000.
6. Husky [WWW] <https://www.clearpathrobotics.com/husky-unmanned-ground-vehicle-robot> (20.09.2016)
7. Pahl, G., Beitz, W., Feldhusen, J., Grote, K.-H. *Engineering Design: A Systematic Approach*. London: Springer, 2007.
8. Sadrpour, A., Jin J., Ulsoy, A.G. Experimental validation of mission energy prediction model for unmanned ground vehicles. *Proc. of 1st American Control Conference 2013*, IEEE, Washington DC, USA, 2013, 5960-5965.
9. Albus, J.S. Metrics and performance measures for intelligent unmanned ground vehicles. *Proc. of Performance Metrics for Intelligent Systems Workshop*, Gaithersburg, Maryland, 2002, 1-8.
10. SysML specification [WWW] <http://sysml.org/>.
11. Delligatti, L. *SysML Distilled*. New Jersey: Pearson Education, 2014.
12. Simonite, T. Data shows Google's robot cars are smoother, safer drivers than you or I. MIT Technology Review [WWW] <https://www.technologyreview.com/s/520746/data-shows-googles-robot-cars-are-smoother-safer-drivers-than-you-or-i> (09.10.2016)
13. Unmanned Systems Technology. Unmanned ground vehicle (UGV) manufacturers [WWW] <http://www.unmannedsystemstechnology.com/category/supplier-directory/platforms/ugvs> (09.10.2016)
14. Milrem AS [WWW] <http://milrem.ee> (09.10.2016)
15. Argo Amphibous UTV [WWW] <http://argoxtr.com/argo-xtr> (09.10.2016)
16. ASI Robotics Ltd. [WWW] <https://www.asirobots.com> (09.10.2016)

17. Starship Technologies OÜ [WWW] <https://www.starship.xyz> (09.10.2016)
18. Tracdrono OÜ [WWW] <http://tracdrono.com> (09.10.2016)
19. Qinetiq Talon [WWW] <https://www.qinetiq.com/services-products/land/UGV/Documents/brochure-talon.pdf> (10.10.2016)
20. *VDI 2206: Design methodology for mechatronic systems*. Berlin: Verein Deutscher Ingenieure, 2004.
21. Shetty, D., Kolk, R.A. *Mechatronics System Design, SI Version*. Stamford: Cengage Learning, 2011.
22. Bishop, R.H. *The Mechatronics Handbook, Second Edition*. CRC Press, 2007.
23. Tunstel, E. Operational performance metrics for Mars exploration rovers. *Journal of Field Robotics*, 2007, 24 (8/9), 651–670.
24. Thueer, T., Siegwart, R. Mobility evaluation of wheeled all-terrain robots. *Robotics and Autonomous Systems*, 2010, 58, 508-519.
25. Lampe, A., Chatila, R. Performance measure for the evaluation of mobile robot autonomy. *Proc. of IEEE International Conference on Robotics and Automation*, Orlando, USA, 2006, 4057-4062.
26. Pepper, C., Balakirsky, S., Scrapper, C. Robot simulation physics validation. *Proc. of Performance Metrics for Intelligent Systems Workshop*, Galthersburg, 2007, 97-104.
27. Calisi, D., Iocchi, L., Nardi, D. A unified benchmark framework for autonomous mobile robots and vehicles motion algorithms. *Proc. of RSS workshop on experimental methodology and benchmarking*, Zurich, Switzerland, 2008.
28. Muñoz, N.D., Valencia, J.A., Londoño, N. Quantitative performance metrics for mobile robots navigation. *Mobile Robots Navigation*, 2010, 485-500.
29. NIST Robotics Test Facility [WWW] <https://www.nist.gov/laboratories/tools-instruments/robotics-test-facility>
30. NERVE Center, University of Massachusetts [WWW] <http://nerve.uml.edu/> (10.10.2013)
31. van Diggelen, J., Looije, R., Mioch, T., Neerinx, M.A., Smets, N.J.J.M. Usage-centered evaluation methodology for unmanned ground vehicles. *Proc. of 5th International Conference on Advances in Computer-Human Interactions*, Valencia, Spain, 2012, 186-191.
32. Jacoff, A., Huang, H.M., Virts, A., Downs, A., Sheh, R. Emergency response robot evaluation exercise. *Proc. of ACM Workshop on Performance Metrics for Intelligent Systems*, Maryland, USA, 2012, 145-154.
33. Jacoff, A., Sheh, R., Virts, A.M., Kimura, T., Pellenz, J., Schwertfeger, S., Suthakorn, J. Using competitions to advance the development of standard test methods for response robots. *Proc. of ACM Workshop on Performance Metrics for Intelligent Systems*, Maryland, USA, 2012, 182-189.

34. Wong, S.C., Middleton, L., MacDonald, B.A. Performance metrics for robot coverage tasks. *Proc. of Australasian Conference on Robotics and Automation*, Auckland, New Zealand, 2002, 7-12.
35. Hazon, N., Kaminka, G.A. Redundancy, efficiency and robustness in multi-robot coverage. *Proc. of the 2005 IEEE International Conference on Robotics and Automation*, Barcelona, Spain, 2005, 735-741.
36. Xu, L., Stentz, A. An efficient algorithm for environmental coverage with multiple robots. *Proc. of Robotics and Automation (ICRA)*, IEEE International Conference, Shanghai, China, 2011, 4950-4955.
37. Steinfeld, A. et al. Common metrics for human-robot interaction. *Proc. of the 1st ACM SIGCHI/SIGART conference on Human-robot interaction*, Salt Lake City, USA, 2006, 297-304.
38. Freire, E.O. et al. Human based benchmark for robot navigation assessment [WWW]
http://www.academia.edu/download/43795850/Human_Based_Benchmark_for_Robot_Navigation20160316-16832-1iipv35.pdf (30.09.2016)
39. Flanagan, C. A survey of robotics systems and performance analysis [WWW] <http://www.cse.wustl.edu/~jain/cse567-11/ftp/robots> (02.10.2016)
40. Unhelkar, V.V., Siu, H.C., Shah, J.A. Comparative performance of human and mobile robotic assistants in collaborative fetch-and-deliver tasks. *Proc. of the 2014 ACM/IEEE international conference on Human-robot interaction*, New York, USA, 2014, 82-89.
41. Halme, A., Leppänen, I., Suomela, J., Ylönen, S., Kettunen, I. WorkPartner: interactive human-like service robot for outdoor applications. *International Journal of Robotics Research*, 2003, 22, 627-640.
42. De Michieli, L., Nori, F., Sandini, G. Energy efficiency in humanoid robots. A preliminary study on a humanoid torso. *Proc. of 8th IEEE-RAS International Conference on Humanoid Robots*, Daejeon, South-Korea, 2008.
43. Calisi, D., Nardi, D. Performance evaluation of pure-motion tasks for mobile robots with respect to world models. *Autonomous Robot*, 2009, 27, 465-481.
44. Cantelli, L., Presti, M.L., Mangiameli, M., Melita, C.D., Muscato, G. Autonomous Cooperation between UAV and UGV to improve navigation and environmental monitoring in rough environments. *Proc. of the 10th International symposium HUDEM*, Šibenik, Croatia, 2013, 109-112.
45. Broderick, J.A., Tilbury, D.M., Atkins, E.M. Optimal coverage trajectories for a UGV with tradeoffs for energy and time. *Autonomous Robot*, 2013, 36, 257-271.
46. Sadrpour, A., Jionghua, J. Real-time energy-efficient path planning for unmanned ground vehicles using mission prior knowledge. *Vehicle Autonomous Systems*, 2014, 12, 221-246.

47. Appelqvist, P., Knuuttila, J., Ahtiainen, J. Mechatronics design of an unmanned ground vehicle for military applications. *INTECH Open Access Publisher*, 2010, 237-262.
48. Bugár, M., Stanak, V., Ferencey, V. Hybrid powertrain conceptual design for unmanned ground vehicle. *Science & Military Journal*, 2011, 6, 13-19.
49. Strupler, P., Pradalier, C., Siegwart, R. Terrain mapping and control optimization for a 6-wheel rover with passive suspension. *Springer Tracts in Advanced Robotics*, 2014, 92, 297-300.
50. Iagnemma, K., Ward, C.C. Classification-based wheel slip detection and detector fusion for mobile robots on outdoor terrain. *Springer Autonomous Robots*, 2009, 26, 33-46.
51. Krebs, A., Risch, F., Thuerer, T., Maye, J., Pradalier, C., Siegwart, R. Rover control based on an optimal torque distribution - application to 6 motorized wheels passive rover. *Proc. of IEEE/RSJ International Conference on Intelligent Robots and Systems*, Taipei, Taiwan, 2010, 4372-4377.
52. Shamah, B., Wagner, M.D., Moorehead, S., Teza, J., Wettergreen, D., Whittaker, W. Steering and control of passively articulated robot [WWW]
https://www.ri.cmu.edu/pub_files/pub3/shamah_benjamin_2001_1/shamah_benjamin_2001_1.pdf (13.09.2016)
53. Nie, C., Assaliyski, M., Spenko, M. Design and experimental characterization of an omnidirectional unmanned ground vehicle for unstructured terrain. *Robotica*, 2015, 33, 1984-2000.
54. Wu, X., Freese, D., Cabrera, A., Kitch, W.A. Electric vehicles' energy consumption measurement and estimation. *Transportation Research Part D: Transport and Environment*, 2015, 34, 52-67.
55. Ulsoy, A.G., Peng, H., Çakmakci, M. *Automotive Control Systems*. Cambridge: Cambridge University Press, 2014.
56. Sandberg, U. (ed.). Rolling resistance - basic information and state-of-the-art on measurement methods, models for rolling resistance in road infrastructure asset management systems (MIRIAM) [WWW]
http://miriam-co2.net/Publications/MIRIAM_SoA_Report_Final_110601.pdf (13.09.2016)
57. Andersen, L.G., Larsen, J.K., Fraser, E.S., Schmidt, B., Dyre, J.C. Rolling resistance measurement and model development. *Journal of Transportation Engineering*, 2014, 141(2), 1-10.
58. Våljaots, E., Trolla, J. Evaluation of low-cost inertial based road pavement smoothness measurement equipment. *Proc. of 28th International Baltic Road Conference*, Vilnius, Lithuania, 2013, 245-250.
59. Frith, W., Cenek, P. AA research: standard metrics for transport and driver safety and fuel economy. Opus International Consultants Central Laboratories, 2012.

60. Kusano, K.D., Gabler, H. Method for estimating time to collision at braking in real-world, lead vehicle stopped rear-end crashes for use in pre-crash system design. *SAE International*, 2011, 4-1, 435-439.
61. Zoz, F.M., Grisso, R.D. Traction and tractor performance. *Proc. of Agricultural Equipment Technology Conference*, Louisville, USA, 2003.
62. Schreckenghost, D., Milam, T., Fong, T. Measuring performance in real time during remote human-robot operations with adjustable autonomy. *IEEE Intelligent Systems*, 2010, 25-5, 36-45.
63. Nguyen-Huu, P.-N., Titus, J. Reliability and failure in unmanned ground vehicle (UGV). GRRC Technical Report 2009-01, University of Michigan, 2009.
64. Våljaots, E., Laaneots, R., Sell, R. Uncertainty in ground vehicle dynamics measurement system. *Системи обробки інформації*, 2011, 1 (91), 52-56.
65. Grewal, M.S., Weill, L.R., Andrews, A.P. *Global Positioning Systems, Inertial Navigation and Integration*. Hoboken: John Wiley & Sons Inc, 2007.
66. Woodman, O.J. An introduction to inertial navigation. Technical report no 696. University of Cambridge, 2007.
67. Siciliano, B., Khatib, O. *Springer Handbook of Robotics*. London: Springer, 2008.
68. Christophe, F., Sell, R., Bernard, A., Coatanea, E. OPAS: ontology processing for assisted synthesis. *Proc. of the ASME 2009 International Design Engineering Technical Conferences & Design Automation Conference*, San Diego, USA, 2009, 249-260.
69. Sell, R., Coatanea, E., Christophe, F. Important aspects of early design in mechatronics. *Proc. of 6th International Conference of DAAAM Baltic Industrial Engineering*, Tallinn, 2008, 177-182.
70. Sell, R., Leomar, P. Universal navigation algorithm planning platform for unmanned systems. *Proc. of International Conference Mechatronic Systems and Materials*, Vilnius, Lithuania, 2009, 405-410.
71. Norcar Mincomatic 660 [WWW] <http://www.minkomatic.com/en/feed-trucks/660670/660/> (10.09.2016)
72. Sell, R., Seiler, S. Mechatronics modeling methodology and semantic orientated knowledge base. *Proc. of 20th International DAAAM Symposium*, Vienna, Austria, 2009, 1723-1724.

ABSTRACT

Energy Efficiency Evaluation Method for Mobile Robot Platform Design

Unmanned ground vehicle market is expected to grow exponentially with many competitive designs being developed also for applications in the civil field. While the expenses for automation and robotics technology have decreased, the development complexity is increasing and the lead times to market are shrinking, which requires considerable effort to tune the autonomous platform performance and efficiency to a competitive level. Designing a complex mechatronic system is a time-consuming task with expensive prototype building and a lot of trial-error testing. Practical usable systems for prototype performance evaluation and validated model databases can improve the platform early design phase and speed up new concept generation for applications.

This thesis is focused on the efficiency validation method that provides a link between the UGV design models and their real-condition operational efficiency. Although platforms are usually designed with more or less universal capabilities, their most efficient operating area is much narrower. Efficiency metrics for universal platforms are established by mapping tasks and missions in the planned range of use taking into account the environment and terrain properties. This enables compilation of efficiency profiles to particular platforms that also present energy consumption distribution. Profiles are used to improve and optimize UGV design, control systems and their comparison to find the most suitable for a given task. The thesis research is part of the general mobile robot development framework incorporating methodologies, tools and experimental data focusing on the early stage product design support.

Based on the goals, the following tasks were solved:

- Analysis of efficient operation properties of tasks and missions assigned to universal mobile platforms. Requirements for efficiency are established based on task properties and the corresponding key parameters selected.
- A method for testing the key parameters of the mobile platform efficiency was developed to validate the design in real condition.
- Efficiency profiles for mobile platforms that describe their design suitability to the field of application were developed. This enables easy comparison of different platforms and improvements in the design and technical solutions can be made.
- Platform efficiencies were validated and compared based on real-condition measurement tests. Three different mid-size wheeled platforms were used to accomplish the territory surveillance mission.

In the current research, a method for evaluating operational and design efficiency of the mobile platform was created. Based on the real-condition testing, efficiency and energy consumption distribution profiles were created for platforms and improvements were suggested for design. Although robotic

platforms can use different moving and steering principles or power source, the method enables comparison of efficiency based on the performance and energy consumption, regardless of the design. All results were saved into the database, which enhances the efficiency forecasting considerably for future uses. The current work contributes to the standardized performance evaluation of autonomous platforms.

Keywords: unmanned ground vehicle, mobile robotics, energy efficiency, design validation.

KOKKUVÕTE

Liikuva robotplatvormi energia efektiivsuse hindamise meetod

Mehitamata sõiduvahendite turule ennustatakse järsku kasvu. Lisaks militaarotstarbele arendatakse järjest enam selliseid tooteid ka tsiviilotstarbeliseks kasutamiseks. Koos automaatika- ja robotikaalaste tehnoloogiate odavnemise ja kasutusala laienemisega kasvab ka tootearenduse keerukus, samas kui arenduse aeg järjest väheneb. Selline olukord nõuab inseneridelt märkimisväärset pingutust autonoomsete platvormide suutlikkuse ja efektiivsuse arendamiseks konkurentsivõimelisele tasemele. Keeruka mehhatroonilise süsteemi projekteerimine on ajamahukas ülesanne, millega kaasneb kallis prototüübiehitus ning palju testimist. Praktiliselt kasutatav süsteem prototüüpide suutlikkuse hindamiseks ja sellel baseeruv valideeritud konstruktsioonimudelite teek aitaks oluliselt kiirendada robotplatvormide tootearenduse varasemat, kontseptuaalset etappi ning lühendada uute lahenduste väljatöötamise aega.

Käesolev doktoritöö keskendub mehitamata liikuva platvormide efektiivsuse valideerimise meetodika loomisele, mis ühendaks robotite mudelid nende toimimise efektiivsusega planeeritud kasutustingimustes. Kuigi platvormid projekteeritakse enamasti rohkem või vähem universaalsed, on nende kõige efektiivsem kasutusala märksa kitsam. Efektiivsust kõige paremini kirjeldavad parameetrid tuletatakse kasutusala ülesannete kaardistamise teel, võttes arvesse keskkonna ja maastiku omadusi. Selle põhjal on võimalik koostada uuritavale platvormile efektiivsuse profiil, mis ühtlasi esitab ka selle energiatarbe jaotust. Neid profiile kasutatakse mehitamata sõidukite konstruktsiooni ja juhtsüsteemi arenduseks ning optimeerimiseks, samuti erinevate tehniliste lahenduste ja platvormide omavaheliseks võrdluseks ning parima kasutusotstarbe leidmiseks. Tehtud uurimustöö on osa üldisest mobiilsete robotite arenduse raamistikust, mis sisaldab erinevaid meetodeid, töövahendeid ja katseandmete teeki ning on mõeldud toetama tootearenduse varast etappi.

Eesmärkidest lähtuvalt lahendati järgmised ülesanded:

- analüüsiti robotitele määratud ülesannete seatavaid efektiivse toimimise nõudeid. Nende nõuete baasil on väljatöötatud vastavad võtmeparameetrid.
- Arendati meetodika, mis võimaldab süstematiseerida ja testida robotite efektiivsuse võtmetegureid reaalses oludes ja sellega valideerida nende tehnilisi lahendusi.
- Koostati robotitele efektiivsuse profiilid, mis ühendades mudelid katseandmetega, kirjeldavad nende konstruktsiooni ja kasutatavate tehniliste lahenduste sobivust planeeritud kasutusala. Profiilid võimaldavad platvormide omavahelist võrdlust ning nende põhjal parandada tootearendust.

- Loodud metoodika abil võrreldi kolme platvormi reaalses tingimustes läbiviidud katsete põhjal. Selleks oli võimalik kasutada erineva ehitusega, kuid keskmise suurusega ja ratastel liikuvat robotplatvormi.

Töö tulemuseks on metoodika väljatöötlus mobiilsete robotplatvormide toimimise ja konstruktsiooni efektiivsuse hindamiseks. Välikatsetele tuginedes on robotitele koostatud efektiivsuse ja energiatarbe jaotuse profiilid ja vastavalt soovitatud konstruktsiooni täiustusi. Kuigi platvormide liikumise ja pööramise põhimõtted ning energiaallikad võivad olla erinevad, võimaldab metoodika võrrelda neid olenemata konstruktsioonist vaid suutlikkuse ja energiatarbe põhjal. Tulemused kogutakse teeki, mis lihtsustab konstruktsiooni toimise efektiivsuse ennustamist tulevikulahendustes. Käesolev töö on oluline samm robotplatvormide standardiseeritud suutlikkuse hindamiseks.

LIST OF PUBLICATIONS

1. Väljaots, E., Sell, R., Rimašauskas, M. Unmanned Ground Vehicle Energy Efficiency Validation in Territory Surveillance Mission. *Solid State Phenomena*, 2016, 251, 164–171, <http://www.scientific.net/SSP.251>.
2. Väljaots, E., Sell, R., Kaeeli, M. Motion and Energy Efficiency Parameters of Unmanned Ground Vehicle. *Solid State Phenomena*, 2015, 220-221, 934–939, <http://www.scientific.net/SSP.220>.
3. Väljaots, E., Sell, R. Unmanned ground vehicle SysML navigation model conducted by energy efficiency. *Proc. of Advanced Materials Research*, 2014, 905, 443-447.
4. Väljaots, E., Trolla, J. Evaluation of low-cost inertial based road pavement smoothness measurement equipment. *Proc. of 28th International Baltic Road Conference*, Vilnius, Lithuania, 2013, 245-250.
5. Väljaots, E., Sell, R. Dynamic motion energy efficiency measurement of ground vehicles. *Proc. of 8th International DAAAM Baltic Conference "Industrial Engineering"*, Tallinn, Estonia, 2012, 367-372.
6. Väljaots, E., Laaneots, R., Sell, R. Uncertainty in ground vehicle dynamics measurement system. *Системи обробки інформації*, 2011, 1 (91), 52-56.
7. Väljaots, E., Sell, R. Measurement method and device for vehicle Dynamics. *Proc. of 7th International DAAAM Baltic Conference "Industrial Engineering"*, Tallinn, Estonia, 2010, 536-541.

ELULOOKIRJELDUS

1. Isikuandmed

Nimi Eero Väljaots
Sünniaeg ja -koht 29.05.1982 Tallinn

2. Kontaktandmed

Aadress Paldiski mnt 157-31, 13518 Tallinn
Telefon +372 5650 6528
E-post eero.valjaots@gmail.com

3. Hariduskäik

Õppeasutus	Lõpetamise aeg	Haridus
Tallinna Tehnikaülikool	2009	Mehhatroonika (magister)
Tallinna Tehnikaülikool	2006	Tootearendus (bakalaureus)
Tallinna Õismäe Humanitaargümnaasium	2001	(keskharidus)

4. Keelteoskus

Keel	Tase
Eesti	emakeel
Inglise	kesktase
Saksa	algtase
Vene	algtase

5. Teenistuskäik

Töötamise aeg	Organisatsioon	Ametikoht
2003 ... 2014	Englo OÜ	mehhatroonikainsener
2011 ...	Hecada OÜ	tegevjuht
2014 ...	Wisevelocity OÜ	tehnoloogijuht

6. Kaitsstud lõputööd

Magistritöö: Sõiduki dünaamika mõõtevahend, 2009, juhendaja Raivo Sell, Tallinna Tehnikaülikool

Bakalaureusetöö: Pinnase elastsusmooduli mõõtevahend, 2006, juhendaja Rein Laaneots, Tallinna Tehnikaülikool

7. Teadustöö põhisuunad

Mehitamata maismaasõidukid, sõiduki dünaamika mõõtmine.

CURRICULUM VITAE

1. Personal data

Name Eero Väljaots
Date and place of birth 29.05.1982 Tallinn

2. Contact information

Address Paldiski mnt 157-31, 13518 Tallinn
Phone +372 5650 6528
E-mail eero.valjaots@gmail.com

3. Education

Institution	Graduated	Speciality
Tallinn University of Technology	2009	Mechatronics (M.Sc)
Tallinn University of Technology	2006	Product development (B.Sc)
Tallinna Õismäe Humanitaargümnaasium	2001	(high school education)

4. Language skills

Language	Level
Estonian	native speaker
English	intermediate
German	elementary
Russian	elementary

5. Professional employment

Period	Organization	Position
2003 ... 2014	Englo OÜ	mechatronics engineer
2011 ...	Hecada OÜ	CEO
2014 ...	Wisevelocity OÜ	technology manager

6. Defended theses

Master's thesis: Vehicle dynamics measurement device, 2009, supervisor Raivo Sell, Tallinn University of Technology

Bachelor's thesis: Soil elastic modulus measurement device, 2006, supervisor Rein Laaneots, Tallinn University of Technology

7. Main research interest

Unmanned ground vehicles, vehicle dynamics measurement.

**DISSERTATIONS DEFENDED AT
TALLINN UNIVERSITY OF TECHNOLOGY ON
*MECHANICAL ENGINEERING***

1. **Jakob Kübarsepp**. Steel-Bonded Hardmetals. 1992.
2. **Jakub Kõo**. Determination of Residual Stresses in Coatings & Coated Parts. 1994.
3. **Mart Tamre**. Tribocharacteristics of Journal Bearings Unlocated Axis. 1995.
4. **Paul Kallas**. Abrasive Erosion of Powder Materials. 1996.
5. **Jüri Pirso**. Titanium and Chromium Carbide Based Cermets. 1996.
6. **Heinrich Reshetnyak**. Hard Metals Serviceability in Sheet Metal Forming Operations. 1996.
7. **Arvi Kruusing**. Magnetic Microdevices and Their Fabrication methods. 1997.
8. **Roberto Carmona Davila**. Some Contributions to the Quality Control in Motor Car Industry. 1999.
9. **Harri Annuka**. Characterization and Application of TiC-Based Iron Alloys Bonded Cermets. 1999.
10. **Irina Hussainova**. Investigation of Particle-Wall Collision and Erosion Prediction. 1999.
11. **Edi Kulderknup**. Reliability and Uncertainty of Quality Measurement. 2000.
12. **Vitali Podgurski**. Laser Ablation and Thermal Evaporation of Thin Films and Structures. 2001.
13. **Igor Penkov**. Strength Investigation of Threaded Joints Under Static and Dynamic Loading. 2001.
14. **Martin Eerme**. Structural Modelling of Engineering Products and Realisation of Computer-Based Environment for Product Development. 2001.
15. **Toivo Tähemaa**. Assurance of Synergy and Competitive Dependability at Non-Safety-Critical Mechatronics Systems design. 2002.
16. **Jüri Resev**. Virtual Differential as Torque Distribution Control Unit in Automotive Propulsion Systems. 2002.
17. **Toomas Pihl**. Powder Coatings for Abrasive Wear. 2002.
18. **Sergei Letunovitš**. Tribology of Fine-Grained Cermets. 2003.
19. **Tatyana Karaulova**. Development of the Modelling Tool for the Analysis of the Production Process and its Entities for the SME. 2004.
20. **Grigori Nekrassov**. Development of an Intelligent Integrated Environment for Computer. 2004.
21. **Sergei Zimakov**. Novel Wear Resistant WC-Based Thermal Sprayed Coatings. 2004.

22. **Irina Preis.** Fatigue Performance and Mechanical Reliability of Cemented Carbides. 2004.
23. **Medhat Hussainov.** Effect of Solid Particles on Turbulence of Gas in Two-Phase Flows. 2005.
24. **Frid Kaljas.** Synergy-Based Approach to Design of the Interdisciplinary Systems. 2005.
25. **Dmitri Neshumayev.** Experimental and Numerical Investigation of Combined Heat Transfer Enhancement Technique in Gas-Heated Channels. 2005.
26. **Renno Veinthal.** Characterization and Modelling of Erosion Wear of Powder Composite Materials and Coatings. 2005.
27. **Sergei Tisler.** Deposition of Solid Particles from Aerosol Flow in Laminar Flat-Plate Boundary Layer. 2006.
28. **Tauno Otto.** Models for Monitoring of Technological Processes and Production Systems. 2006.
29. **Maksim Antonov.** Assessment of Cermets Performance in Aggressive Media. 2006.
30. **Tatjana Barashkova.** Research of the Effect of Correlation at the Measurement of Alternating Voltage. 2006.
31. **Jaan Kers.** Recycling of Composite Plastics. 2006.
32. **Raivo Sell.** Model Based Mechatronic Systems Modeling Methodology in Conceptual Design Stage. 2007.
33. **Hans Rämmal.** Experimental Methods for Sound Propagation Studies in Automotive Duct Systems. 2007.
34. **Meelis Pohlak.** Rapid Prototyping of Sheet Metal Components with Incremental Sheet Forming Technology. 2007.
35. **Priidu Peetsalu.** Microstructural Aspects of Thermal Sprayed WC-Co Coatings and Ni-Cr Coated Steels. 2007.
36. **Lauri Kollo.** Sinter/HIP Technology of TiC-Based Cermets. 2007.
37. **Andrei Dedov.** Assessment of Metal Condition and Remaining Life of In-service Power Plant Components Operating at High Temperature. 2007.
38. **Fjodor Sergejev.** Investigation of the Fatigue Mechanics Aspects of PM Hardmetals and Cermets. 2007.
39. **Eduard Ševtšenko.** Intelligent Decision Support System for the Network of Collaborative SME-s. 2007.
40. **Rünno Lumiste.** Networks and Innovation in Machinery and Electronics Industry and Enterprises (Estonian Case Studies). 2008.
41. **Kristo Karjust.** Integrated Product Development and Production Technology of Large Composite Plastic Products. 2008.

42. **Mart Saarna.** Fatigue Characteristics of PM Steels. 2008.
43. **Eduard Kimmari.** Exothermically Synthesized B₄C-Al Composites for Dry Sliding. 2008.
44. **Indrek Abiline.** Calibration Methods of Coating Thickness Gauges. 2008.
45. **Tiit Hindreus.** Synergy-Based Approach to Quality Assurance. 2009.
46. **Karl Raba.** Uncertainty Focused Product Improvement Models. 2009.
47. **Riho Tarbe.** Abrasive Impact Wear: Tester, Wear and Grindability Studies. 2009.
48. **Kristjan Juhani.** Reactive Sintered Chromium and Titanium Carbide-Based Cermets. 2009.
49. **Nadežda Dementjeva.** Energy Planning Model Analysis and Their Adaptability for Estonian Energy Sector. 2009.
50. **Igor Krupenski.** Numerical Simulation of Two-Phase Turbulent Flows in Ash Circulating Fluidized Bed. 2010.
51. **Aleksandr Hlebnikov.** The Analysis of Efficiency and Optimization of District Heating Networks in Estonia. 2010.
52. **Andres Petritšenko.** Vibration of Ladder Frames. 2010.
53. **Renee Joost.** Novel Methods for Hardmetal Production and Recycling. 2010.
54. **Andre Gregor.** Hard PVD Coatings for Tooling. 2010.
55. **Tõnu Roosaar.** Wear Performance of WC- and TiC-Based Ceramic-Metallic Composites. 2010.
56. **Alina Sivitski.** Sliding Wear of PVD Hard Coatings: Fatigue and Measurement Aspects. 2010.
57. **Sergei Kramanenko.** Fractal Approach for Multiple Project Management in Manufacturing Enterprises. 2010.
58. **Eduard Latõsov.** Model for the Analysis of Combined Heat and Power Production. 2011.
59. **Jürgen Riim.** Calibration Methods of Coating Thickness Standards. 2011.
60. **Andrei Surzhenkov.** Duplex Treatment of Steel Surface. 2011.
61. **Steffen Dahms.** Diffusion Welding of Different Materials. 2011.
62. **Birthe Matsi.** Research of Innovation Capacity Monitoring Methodology for Engineering Industry. 2011.
63. **Peeter Ross.** Data Sharing and Shared Workflow in Medical Imaging. 2011.
64. **Siim Link.** Reactivity of Woody and Herbaceous Biomass Chars. 2011.
65. **Kristjan Plamus.** The Impact of Oil Shale Calorific Value on CFB Boiler Thermal Efficiency and Environment. 2012.
66. **Aleksei Tšinjan.** Performance of Tool Materials in Blanking. 2012.

67. **Martinš Sarkans**. Synergy Deployment at Early Evaluation of Modularity of the Multi-Agent Production Systems. 2012.
68. **Sven Seiler**. Laboratory as a Service – A Holistic Framework for Remote and Virtual Labs. 2012.
69. **Tarmo Velsker**. Design Optimization of Steel and Glass Structures. 2012.
70. **Madis Tiik**. Access Rights and Organizational Management in Implementation of Estonian Electronic Health Record System. 2012.
71. **Marina Kostina**. Reliability Management of Manufacturing Processes in Machinery Enterprises. 2012.
72. **Robert Hudjakov**. Long-Range Navigation for Unmanned Off-Road Ground Vehicle. 2012.
73. **Arkadi Zikin**. Advanced Multiphase Tribo-Functional PTA Hardfacings. 2013.
74. **Alar Konist**. Environmental Aspects of Oil Shale Power Production. 2013.
75. **Inge Roos**. Methodology for Calculating CO₂ Emissions from Estonian Shale Oil Industry. 2013.
76. **Dmitri Shvarts**. Global 3D Map Merging Methods for Robot Navigation. 2013.
77. **Kaia Lõun**. Company's Strategy Based Formation of e-Workplace Performance in the Engineering Industry. 2013.
78. **Maido Hiimaa**. Motion Planner for Skid-Steer Unmanned Ground Vehicle. 2013.
79. **Dmitri Goljandin**. Disintegrator Milling System Development and Milling Technologies of Different Materials. 2013.
80. **Dmitri Aleksandrov**. Light-Weight Multicopter Structural Design for Energy Saving. 2013.
81. **Henrik Herranen**. Design Optimization of Smart Composite Structures with Embedded Devices. 2014.
82. **Heiki Tiikoja**. Experimental Acoustic Characterization of Automotive Inlet and Exhaust System. 2014.
83. **Jelena Priss**. High Temperature Corrosion and Abrasive Wear of Boiler Steels. 2014.
84. **Aare Aruniit**. Thermoreactive Polymer Composite with High Particulate Filler Content. 2014.
85. **Dmitri Gornostajev**. Development of the Calculation Method for Barge Hull. 2014.
86. **Liina Lind**. Wear of PVD Coatings on Fineblanking Punches. 2014.
87. **Nikolai Voltšihhin**. Design and Technology of Oxides-Containing Ceramic-Based Composites. 2014.

88. **Aleksander Šablinski.** RANS Numerical Modelling of Turbulent Polydispersed Flows in CFB Freeboard. 2015.
89. **Tanel Aruväli.** Wireless Real-time Monitoring of Machining Processes. 2015.
90. **Andrei Bogatov.** Morphological Changes on Diamond and DLC Films During Sliding Wear. 2015.
91. **Raimo Kabral.** Aero-Acoustic Studies and Innovative Noise Control with Application to Modern Automotive Gas Exchange System. 2015.
92. **Jevgeni Sahno.** Dynamic Management Framework for Continuous Improvement of Production Processes. 2015.
93. **Ott Pabut.** Optimal Design of Slotless Permanent Magnet Generators. 2015.
94. **Merili Kukuškin.** Value Centric Business Development for Estonian Manufacturing Small and Medium Sized Enterprises. 2015.
95. **Kaimo Sonk.** Development of Additive Manufacturing Based on Functional Requirements. 2015.
96. **Marina Aghayan.** Functionalization of Alumina Nanofibers with Metal Oxides. 2016.
97. **Marek Jõelett.** Titanium Carbide Cermet as Ballistic Protection Material. 2016.
98. **Heikki Sarjas.** Novel Synthesized and Milled Carbide-based Composite Powders for HVOF Spray. 2016.
99. **Klodian Dhoska.** Measurement Methods with 3D Coordinate Measuring Machine and Improved Characterization Setup for Detector Performance. 2016.
100. **Aleksei Snatkin.** Development and Optimisation of Production Monitoring System. 2016.
101. **Igor Poljantšikov.** Partners Selection Tool for Virtual Enterprise in SMEs Network. 2016.
102. **Sergei Žigailov.** Experimental and Analytical Modelling of Pelvic Motion. 2016.
103. **Rommi Källo.** Synergy-Based Chaos Control in the Multi-Agent Hierarchical Systems. 2016.
104. **Der-Liang Yung.** ZrC-based and ZrC-doped Composites for High-Temperature and Wear Applications. 2016.
105. **Viive Pille.** Development of a Model for the Prevention of Work-Related Musculoskeletal Disorders in the Upper Extremities. 2016.
106. **Agus Pramono.** Investigation of Severe Plastic Deformation Processes for Aluminum Based Composites. 2016.
107. **Zorjana Mural.** Technology and Properties of Fine-grained Nd-Fe-B Magnets. 2017.