



TALLINNA TEHNIKAÜLIKOOL
TALLINN UNIVERSITY OF TECHNOLOGY

Faculty of Mechanical Engineering

Department of Mechatronics
Chair of Mechatronics Systems

MHK70LT

Daniil Monich

**DESIGN OF SYSTEM OF POSITIONING
OF THE TOOL**

Master's Thesis

The author applies for
the academic degree
Master of Science in Engineering

Tallinn

2016

AUTHOR'S DECLARATION

I declare that I written this graduation thesis independently.

These materials have not been submitted for any academic degree.

All the works of other authors used in this thesis have been referenced.

The thesis was completed under Robert Hudjakov supervision.

“.....”2016

Author's

..... signature

The thesis complies with the requirements for graduation these.

“.....”2016

Supervisor's

..... signature

Accepted for defence.

Chairman of defence committee

“.....”2016

..... signature



TALLINNA TEHNIKAÜLIKOOL
TALLINN UNIVERSITY OF TECHNOLOGY

Mehaanikateaduskond

Mehhatroonikainstituut

Mehhatroonika süsteemide õppetool

MHK70LT

Daniil Monich

**INSTRUMENDI POSITSIONEERIMISE
SÜSTEEMI PROJEKTEERIMINE**

Master's Thesis

Autor taotleb tehnikateaduse magistri
akadeemilist kraadi

Tallinn

2016

AUTORIDEKLARATSIOON

Deklareerin, et käesolev lõputöö on minu iseseisva töö tulemus.

Esitatud materjalide põhjal ei ole varem akadeemilist kraadi taotletud.

Töös kasutatud kõik teiste autorite materjalid on varustatud vastavate viidetega.

Töö valmis Robert Hudjakov juhendamisel

“.....” 2016

Töö autor

..... allkiri

Töö vastab magistritööle esitatavatele nõuetele.

“.....”2016

Juhendaja

..... allkiri

Lubatud kaitsmisele.

..... õppekava kaitsmiskomisjoni esimees

“.....”2016

..... allkiri

TUT Department of Mechatronics

Chair of Mechatronics Systems

MASTER'S THESIS TASK

Spring semester 2016

Student: Daniil Monich 158881MAHM

Study programme: MAHM-Mechatronics

Spetsiality: Mechatronics

Supervisor: PhD, Robert Hudjakov (TUT)

Supervisor: PhD, Michael Abramchuk (ITMO)

MASTER'S THESIS TOPIC:

(in English). **DESIGN OF SYSTEM OF POSITIONING OF THE TOOL**

(in Estonian) **INSTRUMENDI POSITSIONEERIMISE SÜSTEEMI**

PROJEKTEERIMINE

Assignments to be completed and the schedule for their completion:

| Nr | Description of the assignment | Completion dates |
|----|---|------------------|
| 1. | Search and review of analogues of the spatial positioning systems of the tool. | 10.02.2016 |
| 2. | Derive the equations of kinematics and dynamics. Make a three-dimensional model of the system of positioning. | 10.03.2016 |
| 3. | Make adjustments to the model of the system. Choose the right materials and assemble a prototype. | 10.04.2016 |
| 4. | Test the prototype. Summing up the results of work. | 10.05.2016 |
| 5. | Printing and binding of Master's thesis. | 18.05.2016 |

Engineering and economic problems to be solved: In this master's thesis the model of system of positioning of the tool should be designed. The main aim of the thesis is making prototype of device, on which it is possible to show the principles of the motion.

Additional comments and requirements:.....

Language of the thesis: English

Deadline for submission of the application for defence 16.05.2016

Deadline for submitting the theses 20.05.2016

Student Daniil Monich /signature/date

Supervisor Robert Hudjakov /signature/ date

Confidentiality requirements and other corporate terms and conditions shall be set out on the reverse side.

FOREWORD

This thesis is the final assessment paper of the double-degree programme at University ITMO in St. Petersburg and Tallinn University of Technology. The main theme and field of work were chosen in the process of dialogue among the heads of the Department of Mechatronics of both universities – Professor Musalimov V. M. and Professor Mart Tamre. Writing the thesis took place at the Department of Mechatronics of Tallinn University of Technology.

I would like to express my gratitude to the two universities for the opportunity to get the great experience in the field of mechatronics and robotics. And a special thanks to the Department of Mechatronics of Tallinn University of Technology for providing the access to the laboratories and computer classes, which have all the necessary equipment and software to achieve excellent results in researches.

I would like to express personal thanks to the teaching personnel of the Department of Mechatronics of University ITMO for supervision and assistance in solving the design and analysis problems. I would also like to thank the personnel of the Department of Mechatronics of Tallinn University of Technology for helping in the organization of work in the laboratories, for providing supervision on materials and equipment, for technical support.

Special thanks I express to my supervisors Michael Abramchuk (University ITMO) and Robert Hudjakov (Tallinn University of Technology) for providing their knowledge and experience throughout the work, for help in the theme understanding and choosing the direction of research.

Last, but not insignificant, I would like to thank my parents and friends for their support throughout the period of my study. Their attention and a special attitude helped me to cope with difficulties and reach the final of the period to obtain Master's degree.

ABSTRACT

In this paper, we describe the stages of the design of the positioning system of the tool or the cable-driven robot. The thesis includes the problem statement and definition of the main goals of the work, the description and definition of the features of the parallel mechanisms, identification of prospects for the use of the cable-driven robots, their classification and existing analogues. Enough attention is paid to mathematical analysis, including the kinematics analysis, dynamic analysis and cable tension analysis, due to this there was established the base for the design of other cable mechanisms. The final part of the thesis is devoted to the selection of equipment for prototyping, three-dimensional modeling and design of the cable-driven robot, as well as drawing conclusions and identification of future challenges.

TABLE OF CONTENTS

FOREWORD 2

ABSTRACT 3

1. INTRODUCTION 6

 1.1 Motivation for Research 6

 1.2 Goals and Objectives of the Paper 10

 1.3 Thesis Organization 11

2. LITERATURE REVIEW 12

 2.1 Parallel Mechanisms 12

 2.1.1 Features of Kinematics 13

 2.1.2 Features of Workspace 13

 2.1.3 Features of Motion 14

 2.2 Cable–Driven Robots 14

 2.2.1 Classification of the Cable–Driven Robots 16

 2.2.2 Application of the Cable–Driven Robots 19

 2.2.3 Features of Kinematics 21

 2.2.4 Tension Analysis 22

 2.2.5 Features of Design 22

 2.2.6 Dynamic analysis 22

 2.2.7 Control system 22

3. KINEMATIC MODELING 24

 3.1 Model Description 24

 3.2 Kinematics Analysis 25

 3.2.1 Displacement Analysis 25

 3.2.2 Velocity Analysis 28

 3.2.3 Acceleration Analysis 29

 3.2.4 Kinematic Equations for Cable–Driven Robot 29

| | |
|---|----|
| 4. TENSION ANALYSIS | 35 |
| 5. DYNAMIC MODELING | 38 |
| 5.1 Dynamic Model of the Platform | 38 |
| 5.2 Dynamic Model of the Motor | 39 |
| 5.3 Dynamic Model of the System | 41 |
| 5.4 Dynamic Equations for Cable–Driven Robot | 42 |
| 6. PROTOTYPING AND CONTROL | 45 |
| 6.1 Software | 45 |
| 6.2 Field of Application of the Designed Cable–Driven Robot | 47 |
| 6.3 Equipment and Components | 47 |
| 6.3.1 Electronic Components | 47 |
| 6.3.2 Non–Electronic Components of the Construction | 51 |
| 6.3.3 Equipment for Future Use | 54 |
| 6.3.4 The Result of Prototyping | 55 |
| 6.4 Automation of Calculations and Control | 57 |
| 7. CONCLUSION AND FUTURE WORK | 60 |
| CONCLUSION IN ESTONIAN LANGUAGE | 61 |
| REFERENCES | 62 |
| APPENDICES | 67 |
| Appendix A: Drawings | 67 |
| Appendix B: Program Codes | 68 |

1. INTRODUCTION

1.1 Motivation for Research

This thesis I would like to start with the presentation of several important terms to make it clear what will be discussed in this paper, what field of science and engineering it relates to.

Mechatronics is a field of science and engineering dealing with the synergistic integration of mechanics components with electronic, electrical and computer components with the aim of designing and manufacturing new modules, systems, machines and complexes of machines with intelligent control of their functional motions.[1]

Robotics is the branch of science and engineering in the field of mechanization and automation of manual operation, and of human intellectual activity.

Industrial robot is a reprogrammable, multipurpose manipulator designed to implement various predefined material, details, tools or special devices handlings for the purpose of carrying out different operations.[2] Thus, the practical purpose of creating robots is transferring to them the works, which for humans are time-consuming, heavy, monotonous, harmful, and dangerous for life; works in extreme conditions (deep under water, in the outer space, atomic plants, etc.).[3] The robots operate due to a pre-written program and receive data about the outward things with the help of the sensors.

If we consider robots in terms of installation methods, types of connections, potential displacements, it is possible to identify four main groups of robots: serial robot (or manipulators), parallel robots, hybrid robots, and mobile robots.

Serial robot is a multifunctional, equipped with a computer, robot that consists of multiple rigid segments, each of which is connected with the previous and (or) next ones with the help of rotational or translational joints. It has one kinematic chain between the base and the operating device. An example of the robot-manipulator is presented in the Figure 1.1.



Figure 1.1. Serial robot ABB [4]

Parallel robot is a robot whose base and operating device are connected by one or more closed kinematic chains. The robot is shown in the Figure 1.2. It is accepted to call the rigid connection between the base and the operating device leg or arm.



Figure 1.2. The parallel robot [5]

Hybrid robot is a device, which is a combination of a manipulator, mounted on a movable platform of a parallel robot. The example is shown in the Figure 1.3.



Figure 1.3. The hybrid robot [6]

Mobile robot is an automatic machine which has automatically controlled driving chassis. Such robots can be wheeled, tracked or walking, depending on the kind of the chassis. There also can be installed other types of devices listed above. The example of such robot is presented in the Figure 1.4.

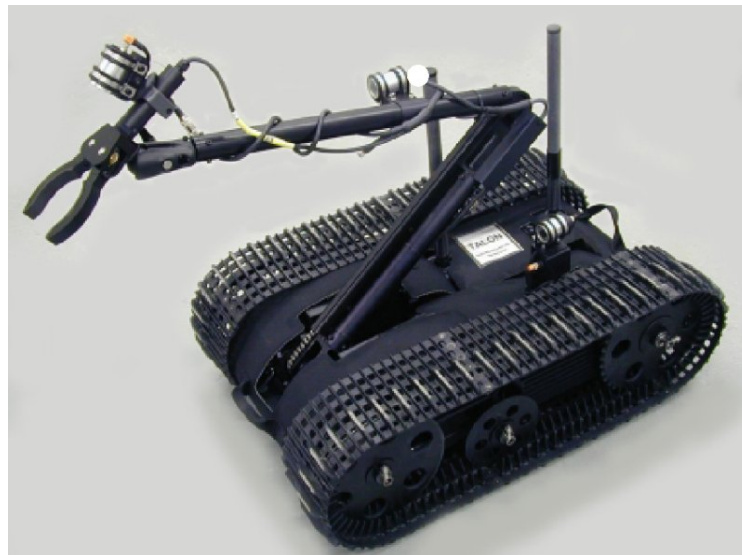

Figure 1.4. Mobile robot [7]

Parallel robots are characterized by a number of advantages over usual serial robots. For parallel mechanisms it is peculiar having several closed kinematic chains and driving by a group of joints. Because of this property, parallel manipulators have great stiffness, high displacement speed and excellent lifting capacity. But, unfortunately, they also have

disadvantages, one of which is a much smaller workspace comparing with simple serial machines. The dexterity can strongly depend on the parameters of the joints; this refers to the design of parallel robots.

Cable-driven robot, or wire-actuated manipulator, is shown in the Figure 1.5. The difference between this robot and the parallel robot is that all the rigid segments are replaced by cables. Thus, we can say that a cable-driven robot is a close-loop mechanism, whose operating device is connected to the base with a few cables. Such robots have relatively simple shape and construction, as well as different numbers of cables connected to the operating device (or the moving platform). Displacement of the moving platform is carried out with the help of the motors, the rotation of which can provide either shortening of the cable, or its elongation. The motors can be statically set on the basis or to be on the moving bases. There can be installed various equipments on the operating device (the moving platform), for example: camera, sensors for any purpose, robotic capture, electromagnets, and different hooks. The used tool depends on the application target of the cable-driven robot.

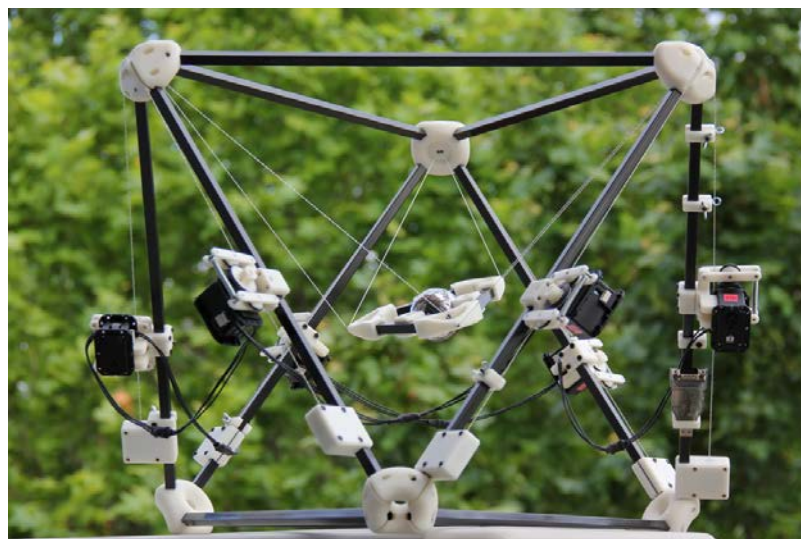

Figure 1.5. Cable-driven robot [8]

Cable-driven robot has some important characteristics:

- Heavy stationary components;
- Moving parts with short-term lag and high rate of acceleration;
- High lifting capacity;
- Potentially large workspace, limited by the length of the cable and its pull-up;

- Ability to rebuild by displacing the motors and updating the control system;
- Low-cost construction and maintenance.

Due to their advantages, cable-driven robots are becoming an alternative to the mechanisms with rigid segments in different areas of applications, for example: transferring, loading and unloading operations in spacious rooms; rescue operations; interaction with hazardous environments; cleaning the areas of natural disasters, etc.

However, it is known that cables have a one-way action (they can pull but cannot push), so the traditional methods and approaches for the mathematical analysis of robots with rigid segments cannot be simply applied for the analysis of the cable-driven robots.

Recent researches of the cable-driven robots include a great number of sections: optimization of the workspace, measuring and maintaining of the cables' tension, resistance to external actions, development of control algorithms, determination of the trajectory of the operating device and its calibration, etc.

1.2 Goals and Objectives of the Paper

As has been noted above, cable-driven robots have several advantages for use in different spheres of activities. Therefore it is very important to have basics for analyzing and designing of similar systems. Thus, this work is devoted to the kinematic analysis, dynamic analysis and demonstration of the operational principle of cable-driven robot in laboratory facility, collected with the use of available parts and equipment.

The paper consists of the following tasks:

- Kinematic analysis, including the finding of displacement equations, rate law and velocity, and acceleration for direct and inverse problems;
- Dynamic analysis of the cable-driven robot
- Analysis of the cable tension;
- Choice of equipment and designing of the cable-driven robot;
- Development of strategies to demonstrate the operational principle of cable-driven robots.

1.3 Thesis Organization

This thesis involves the kinematic modeling, tension analysis, dynamic analysis for cable-driven robots, as well as control strategy of the robots to demonstrate the operational principle of the prototype. In the chapter 2 there is presented a literature review of the selected field of research. The chapter 3 is devoted to the description of the cable-driven robot and its kinematic analysis. In the chapter 4 there is the tension analysis, and in the following chapter – chapter 5 – there is described the dynamic analysis of the cable-driven robot. The chapter 6 is dedicated to the description of the equipment and computer software required to create a prototype of the cable-driven robot. Chapter 7 presents the results of work and future tasks.

2. LITERATURE REVIEW

This part is devoted to the description of the technical sphere and its peculiarities, that is, for a comprehensive understanding of the research, the chapter includes the information about the parallel mechanisms and the environment of its application; about the cable-driven robots and the possible use in various fields.

2.1 Parallel Mechanisms

Parallel robots are mechanisms with a closed-loop system, whose moving platform is connected to the base with at least two series kinematic chains, which are called legs [9]. The example of the parallel robot is presented in the Figure 2.1.

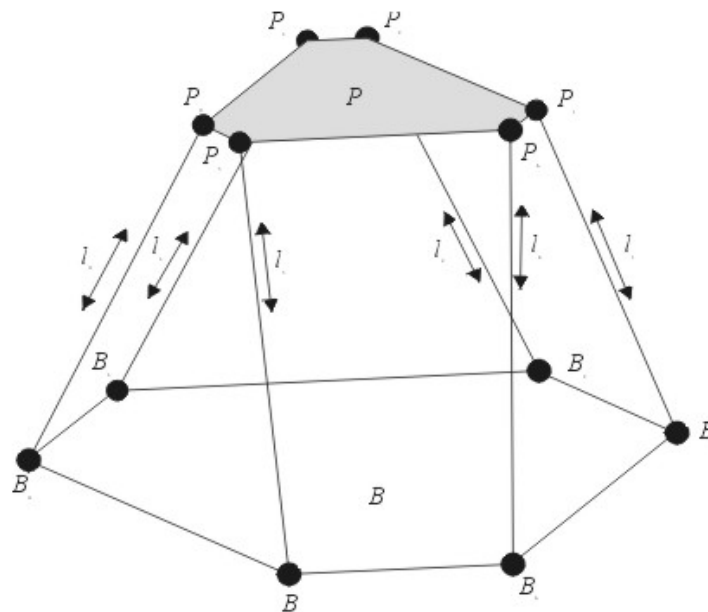

Figure 2.1. Parallel mechanism [10]

Beginning the development path with Stewart platform, which was developed for flight simulation by reproducing the basic motions in space [11], the parallel mechanisms have found the application in various fields, for example: for remote manual control of equipment [12], devices for high-velocity manufacturing [13], high-precision surgical instruments [14] and reconfigurable modular robots[15].

Parallel mechanisms possess high stiffness and stability, good split of operating load to their own weight, as well as extended positioning precision in comparison with the other mechanisms of the similar size [16]. It is possible due to the combination of the moving

platform with the base with the help of several serial chains having with parallel ignition. Furthermore, the parallel mechanisms are able to provide rather compound motions for the moving platform along a complex trajectory, as well as many degrees of freedom due to the combined use of different joints such as universal, spherical, revolute and prismatic joints.

On the back of the marked advantages of the parallel mechanisms using it is possible to identify some of their disadvantages. The use of closed kinematic chains leads to restriction of the moving platform's motions, and also defines different features of the workspace. We can say that these complex features and limitations of the workspace are the main two drawbacks of the parallel mechanisms. Paying attention to the great advantages of the parallel mechanism's using, many researchers in the world focus on the solving of optimization problems and maximization of the workspace, as well as the identification and description of the features. This gives a basis for future competent and successful designing of the construction and the control systems of various types of the parallel mechanisms [17].

2.1.1 Features of Kinematics

Due to the fact that the parallel mechanisms have some kind of completeness, their direct kinematics is complicated, as it comes down to strongly nonlinear equations with set of solutions [18]. On the other hand, the inverse kinematics of such mechanisms is quite simple and requires the simple substitution to obtain a unique solution for the predetermined position. The previous researches of the direct kinematics [19] were based on three main approaches: extra-sensor, polynomial, and numerical-iterative approach. The extra-sensor approach has a high realizable cost and requires sophisticated equipment, and the polynomial-based approach is characterized by the complex reducing process of the equation set in a high order polynomial. Therefore, the numerical-iterative approach has received the most widespread application. One of such methods is Newton-Raphson method, which is popular due to its property of quadratic convergence property. However, there may be some problems in this method with the reliability and precision, associated with the sensitivity to the initial value of the evaluation. Therefore, to minimize the sensitivity they use the previous point of the trajectory as the initial one [20].

2.1.2 Features of Workspace

One of the important design objectives of the parallel mechanisms is the maximization of the workspace. In order to ensure the maximum workspace gain of a parallel mechanism,

the qualitative and quantitative assessments of the workspace determining geometrical limitations for tasks execution are necessary. The general approach to quantitative assessment of the workspace is the numerical discretization of three-dimensional space on the grids, consisting of appropriately situated points, and determining the solutions of the inverse kinematic problem for each of the points to identify their belonging to the workspace [21]. It is important to understand that the developed mechanism design for ensuring the greater workspace may have undesirable effect such as the dexterity reducing. Therefore it is necessary to consider the quality of the workspace in the process of its maximizations.

2.1.3 Features of Motion

Identifying of motions' characteristics is also a very important objective in the designing of the parallel mechanisms. By such characteristics we mean the positions when the parallel robot has uncontrollable degrees of freedom. One should avoid such situations, as they can cause problems with the mechanism control. Thus, the knowledge of such motions' characteristics is necessary for the designing of operating system and the planning of motion path [22].

As a result, we can say that for the development of an optimal design of the parallel mechanism and the planning of its operating system it is very important to identify the correlation between the motions' characteristics, kinematics and workspace.

2.2 Cable-Driven Robots

The mechanisms, that have heavy rigid segments for the positioning of the moving platform which are replaced with lightweight flexible cables, are called cable-driven robots or cable driven mechanisms. The example is presented in the Figure 1.5. The displacement of the moving platform is carried out with the motors and the cables attached to them. Implementing rotations, the motors provide either lengthening or shortening of the cable's length.

For the first time the idea of the cable-driven robots has been presented in the early 80s of the last century, when National Institute of Standards and Technology (NIST) received sponsorship from the Defense Advances Research Project Agency (DARPA) on the project of a robotic crane, called ROBOCRANE, for use in the ports [23]. In the Figure 2.2 it is possible to notice that the crane is similar to the inverted Stewart platform with six degrees of freedom

and the cables instead of hydraulic cylinders. In this system, the cables are in the permanent tension due to gravity force.

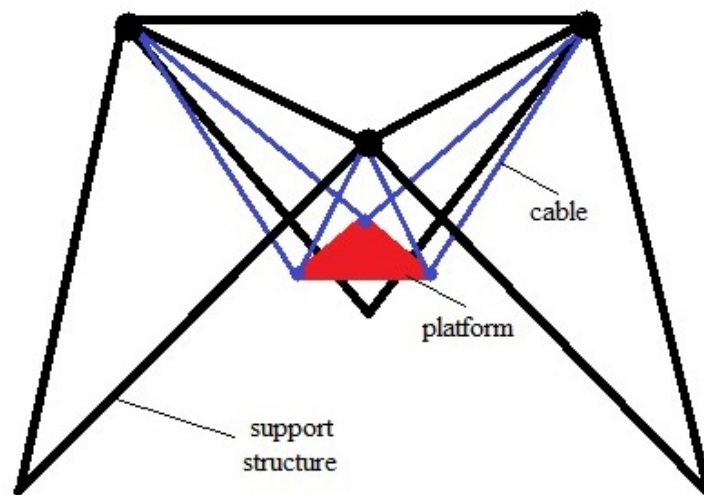

Figure 2.2. ROBOCRANE [24]

The basic idea of ROBOCRANE was to use the Stewart platform, but with some unique characteristics, i.e., rigid segments were replaced by cables, and the length of these cables was regulated with the help of winches. As long as the cables have tension, the load is kinematically constrained, and there is a known correlation between the cables' length and the position of the moving platform. ROBOCRANE was designed to allow the operator to set the position and orientation of the load without whipping and swaying. Moreover, this crane doesn't require balancing weight, and due to its geometric shape it suffers insignificant rotational and bending moments. As a result, ROBOCRANE can lift loads five times greater than its own weight. Others robots and cranes cannot do that.

Taking into account the mentioned above advantages and the possibility of various arrangement of the platform, ROBOCRANE is able to perform a variety of functions such as: loading and unloading works, objects' quality control, pipe laying, various manufacturing operations (welding or cutting) [25]. The Figure 2.3 shows some possible fields of application of ROBOCRANE.



(a) Oil Well Fighting RoboCrane

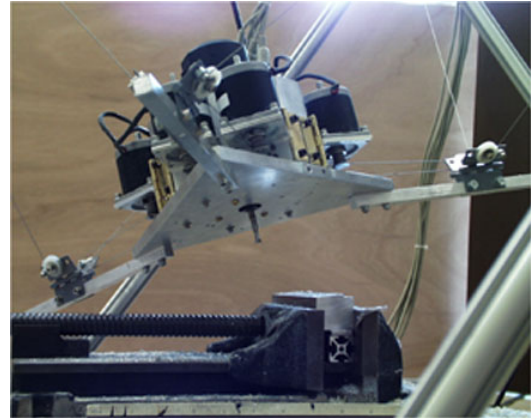

(b) RoboCrane Machine Tool



(c) Bridge Construction RoboCrane

Figure 2.3. Application of ROBOCRANE [26]

2.2.1 Classification of the Cable-Driven Robots

In 1994, scientists Ming and Higuchi [27,28] published the materials for basic understanding of the cable-driven robots. Their work provided necessary and sufficient conditions for the positioning by means of the cables; the rigid segments, equivalent to the cables under tension, were defined; and the main classification of the cable-driven robots was developed.

The position of the moving platform of the cable-driven robots is installed with the help of the cables' lengths. Therefore, the property of one-sidedness (cables cannot push the moving platform) implies that if the cables are not under tension, then the moving platform cannot be precisely controlled. It was mathematically proven that for the cable-driven

mechanisms with the number of degrees of freedom n it is necessary to have $n+ 1$ *active cable* to hold completely the moving platform. Following this, Ming and Higuchi suggested the rigid segment, which is a kinematic equivalent to the active cables. Such correlation includes spherical joints at the ends and one prismatic joint. It is shown in the Figure 2.4 [27].

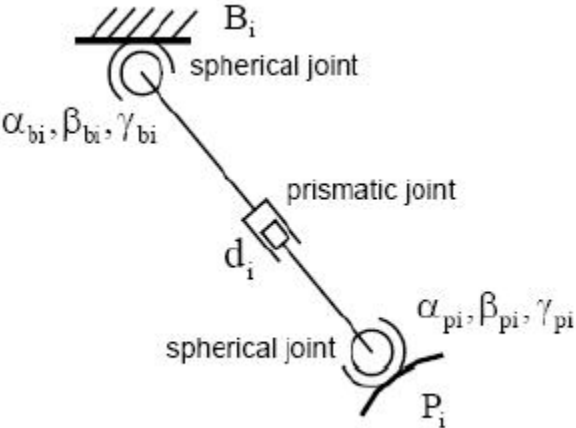
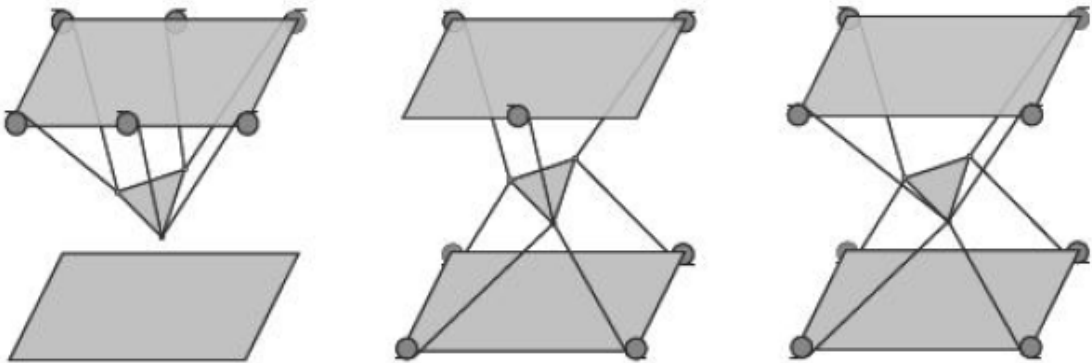

Figure 2.4. Equivalent to the cables [27]

In the following, Ming and Higuchi presented the classification of the cable-driven robots [28]. The separation was whether the robot had enough cables to hold completely the moving platform. Based on this criterion, we can distinguish two categories: incompletely restrained ($m < n+1$) and fully restrained ($m \geq n+1$), where m is the number of cables, and n is the number of degrees of freedom. Fully restrained can also be divided into two groups: completely restrained ($m = n+1$) and redundantly restrained ($m > n+1$). As a result, there is picture the complete classification of the cable-driven robots in the Figure 2.5.



(a) Incompletely restrained (b) Completely restrained (c) Redundantly restrained

Figure 2.5. Classification of the cable-driven robots [29]

Incompletely restrained cable-driven robots: This type of the cable-driven robots is presented in the Figure 2.5(a). For them only of some degrees of freedom to the mobile platform are characteristic, provided by features of the roping, and obtaining of additional constraints is provided by external forces such as gravity force. These robots have quite simple design for execution of tasks where the large workspace is required. However, it is necessary to develop special control strategies to avoid or minimize swaying of the moving platform when displacing.

An example of incompletely restrained cable-driven robots can be a special group of the cable-driven robots with point lumping (Figure 2.6). Usually, the moving platform of such robots is designed so that the mass lumping was at the point of cable fixing, and the displacement is also carried out by changing of the cable length. But in reality, the center of mass of the moving platform is not located exactly at the point of cables' fixing; however, the distance between them is very small comparing to the dimensions of the manipulator.

These robots are pretty good at handling tasks on transportation, like the crane they can also be useful for positioning of the cameras. One of the promising directions of use is a rapidly deployable manipulator for the elimination of consequences of natural disasters [30].

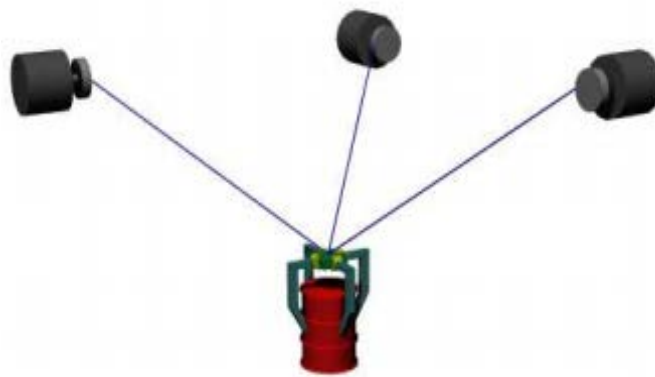

Figure 2.6. Point-mass cable-driven robot [30]

Fully restrained cable-driven robots: The characteristic for such robots is that all degrees of freedom can be defined using the kinematics of the mechanism. These robots have redundancy in the actuation, which expands the workspace, but requires background study of the dispensing of the cables' tension.

Fully restrained cable-driven robots are often designed to perform tasks requiring high system stiffness, high speed and acceleration when displacing. Stiffness is achieved due to the pre-tension of the cables before displacing and saving it in the future. But such robots have disadvantages: the risk of cables' entangling, the need for a large number of motors.

2.2.2 Application of the Cable-Driven Robots

The cable-driven robots can be used to perform completely different tasks. Directions of their application can be flexible manipulators [31], system for legs rehabilitation (Figure 2.7(a)) [32], and the virtual simulation of the tennis (Figure 2.7(b)) [33].

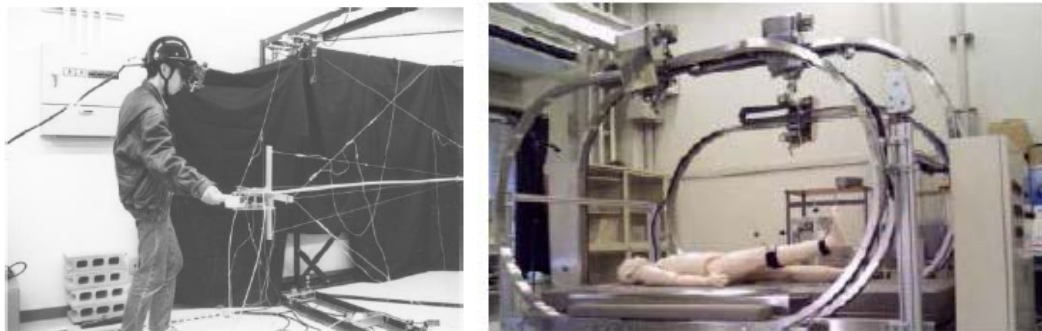

(a) Virtual tennis system [33]

(b) Rehabilitation system [32]

Figure 2.7. Examples of the application of the cable-driven robots

The cable-driven robots can also be used to transfer cargo to the ships and vice versa. An example of such system is the Automated All-Weather Cargo Transfer System (AACTS) [34]. It is shown in the Figure 2.8. The cable-driven robot with six degrees of freedom is mounted in a rigid frame and provides the loading and unloading of various cargoes.



Figure 2.8. Cable-driven robot AACTS [34]

Another example of a cable-driven robot for carrying cargo can be Cable Array [35] Robot. It was developed at the State University of Pennsylvania and is a four-cable mass-point cable-driven robot. The prototype of Cable Array Robot is presented in the Figure 2.9.



Figure 2.9. The prototype of Cable Array Robot [35]

Another example of a mass-point robot is SkyCam. This device is for the positioning of the camera in space, and record keeping and broadcasting of football matches in stadiums and arenas (Figure 2.10) [36].



Figure 2.10. SkyCam [36]

Another example of the application of the cable-driven robots for rehabilitation is the system of STRING-MAN [37]. It was developed in 2007 and designed to restore and exercise the human musculoskeletal system. This system is presented in the Figure 2.11. It has seven cables and a moving track in the base. The cables are attached to the human body and as a result it appears to be a moving operating element of the cable-driven robot.



Figure 2.11. STRING-MAN [37]

2.2.3 Features of Kinematics

All the cables of the cable-driven robot are under tension, so the kinematic analysis of the cable-driven robot is similar to the kinematic analysis of the parallel robot with rigid segments.

Similar to the manipulators with rigid segments, the direct kinematic problem for the cable-driven robots is also quite challenging because of their closed structure, while the inverse kinematic problem is easier and more convenient for analysis. One of the most difficult issues of the kinematic analysis is the direct analysis of displacement when it is necessary to determine the position of the moving platform according to the known cables' length. But due to the motions' characteristics of the robot we obtain the set of solutions of the direct problem. Therefore, the previous researches were focused on numerical algorithms based on the method of Newton-Raphson [38]. However, this method has two drawbacks. The first one is that it gives only one solution in each moment in time. The second solution

depends strongly on the initial approximation. Ming and Higuchi [27] used the results of the parallel mechanism with rigid segments for obtaining of the platform location with the number of degrees of freedom n . This was followed by the use of the inverse kinematics to obtain the lengths of the cable. The use of numerical–iterative approach is much better as it allows one to get quickly the result and can be applied for different cable–driven robots.

2.2.4 Tension Analysis

Since the cables have the ability only to pull but cannot push the moving platform, keeping them in constant tension is very important for the accurate and successful positioning of the platform. Currently, the null space approach is most widely used to tension's store. For full containment of the platform the homogeneous solution is split into a vector column where each element can be expressed in symbolic form [39].

2.2.5 Features of Design

It is important to understand that cable–driven robots can be very diverse. Therefore, before designing, one must decide what it is going to be used for. On this basis it is necessary to observe several conditions to select the optimum design. It is important to determine the required workspace for the moving platform, what stiffness is required, how fast the system must be, how many cables are needed to accomplish the tasks. Based on the purpose of the device it is clear what kind of load the robot will be able to take, whether it will be heavy loads or an easy tool will be used. All this will give the understanding for the accepting of certain design solutions, as well as in the choice of motors and equipment for the control system.

2.2.6 Dynamic analysis

Dynamic analysis is necessary for improving the robot control system when it is operating at high speeds and accelerations. Dynamic modeling connects the moving platform and moments required at the joint for the implementation of the displacement.

2.2.7 Control system

Control system is necessary for the implementation of the moving platform displacement to the predetermined position. It includes software for determining the values required to apply motors control for device. The device is controlled by motors. Feedback is

to account for the errors of the displacement and maintaining of the constant cable tension. All this forms a complex system that allows the robot to complete the task and meet its technical requirements.

Summary: In this chapter there was given a notion of the parallel mechanisms. There were presented the peculiarities of their structure, functionality, advantages and disadvantages, fields of application. Then there were shown the cable-driven robots. It was said where it all began, what papers were used, what objectives were set. There was given the notion of what is the difference between the cable-driven robots and parallel mechanisms, and what they have in common. After that, there was given the classification of the cable-driven robots, there were presented the examples of applications in different fields. There was said about the specifics of the design and key factors that should be considered during development. All this gives the greater vision and understanding about the directivity of this work.

3. KINEMATIC MODELING

This chapter describes in detail the kinematic modeling of the cable-driven robot. The main goal is to derive the equations describing displacement, velocity and acceleration of the cable-driven robot. The kinematics is based on C. B. Pham [29] and M. D. Banadaki [40] works.

3.1 Model Description

In this work the cable-driven robot includes a rigid moving platform that is hung parallel to the ground on the m cables (in this thesis $m=4$). Each of these cables is attached to one of the coils, which in turn are mounted on the motors. During the motor shaft rotation and coils, the cable can either lengthen or shorten. In the Figure 3.1 there are shown the points of attachment of the cables to the moving platform and to the coils. Q_i is the attachment point of the cable to the platform; the D_i is the attachment point of the cable to the coil. $\{0\}$ is a fixed coordinate system, and $\{Q\}$ is the coordinate system of the moving platform. The length of each of the cables is denoted as l_i .

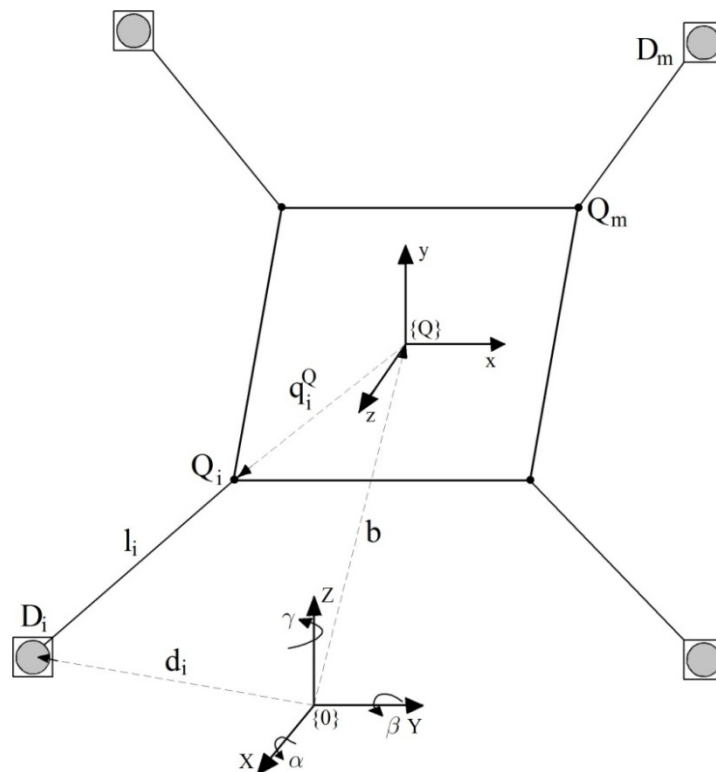

Figure 3.1. Kinematic diagram of cable-driven robot

$b = \overrightarrow{0Q} = \{x \ y \ z\}^T$ – position vector of platform in Cartesian space.

3.2 Kinematics Analysis

The goal of kinematic analysis is to determine the kinematic relations between the cables as the input, and the moving platform as the output. Since the cables are always under tension, it is possible to say that the cable-driven robot kinematics is similar to the kinematics of the parallel robots with rigid segments [16,22]. Similar to the parallel robots, the direct kinematics of a cable-driven robot is quite complicated, while the inverse kinematics is much simpler. The cable-driven robots have complex direct kinematics because of the closed structure, but at the same time, the inverse kinematics is much simpler. As a result, we have one complex task of kinematic analysis – this is a direct displacement analysis, which is finding of the location of the moving platform at the known length of the cable.

3.2.1 Displacement Analysis

The purpose of the displacement analysis is to determine the kinematic connection between the cables' displacement and the platform position. In the Figure 3.1 it is seen that the dependence of the coordinates system {Q} and the coordinate system {0} can be written with the use of the matrix T_Q^0 :

$$T_Q^0 = \begin{bmatrix} R & b \\ 0 & 1 \end{bmatrix} \quad (3.1)$$

Where,

$b = \{x \ y \ z\}^T$ is the position of the point Q relatively to the coordinate system {0}.

$$R = \begin{bmatrix} \cos\gamma\cos\beta & (-\sin\gamma\cos\alpha + \cos\gamma\sin\beta\sin\alpha) & (\sin\gamma\sin\alpha + \cos\gamma\sin\beta\cos\alpha) \\ \sin\gamma\cos\beta & (\cos\gamma\cos\alpha + \sin\gamma\sin\beta\sin\alpha) & (-\cos\gamma\sin\alpha + \sin\gamma\sin\beta\cos\alpha) \\ -\sin\beta & \cos\beta\sin\alpha & \cos\beta\cos\alpha \end{bmatrix}$$

R is an orthonormal rotation matrix that defines the orientation of the coordinate system {Q} relatively to the coordinate system {0}. α , β and γ define the rotation around the axes X, Y and Z respectively in the fixed coordinate system {0} [41].

The position of the point Q_i in the coordinate system {Q} is defined as $q_i^Q = \{q_{i,x}^Q \ q_{i,y}^Q \ q_{i,z}^Q\}^T$ and the position of the point D_i in the coordinate system {0} is written as $d_i = \{d_{i,x} \ d_{i,y} \ d_{i,z}\}^T$. For each cable it is possible to write an expression of closed-loop vector path:

$$\overrightarrow{0D_i} + \overrightarrow{D_iQ_i} = \overrightarrow{0Q} + \overrightarrow{QQ_i} \quad (i = 1, \dots, m) \quad (3.2)$$

As a result we can write that the length of the cable is connected with the position of the platform through the length of the vector l_i .

$$l = \|\overrightarrow{D_iQ_i}\| = \|\overrightarrow{0Q} + \overrightarrow{QQ_i} - \overrightarrow{0D_i}\| = \|b + Rq_i^Q - d_i\| \quad (3.3)$$

Direct displacement analysis

Direct displacement analysis can be used to determine the position of the platform when know the lengths of all cables are known. Both sides of equation (3.3) can be squared and written m times, one for each cable, in which each will have six unacquainted $Z=(x,y,z,\alpha,\beta,\gamma)$.

$$W_i(Z) = (b + Rq_i^Q - d_i)^T (b + Rq_i^Q - d_i) - l_i^2 = 0 \quad (i = 1, \dots, m) \quad (3.4)$$

By setting the length l_i of the cables, it is possible to calculate the position of the platform. But finding the solution of this problem is not simple, since it is necessary to solve a set of highly nonlinear equations, which will have many results while calculating [42].

In the past, the analytical solution of the task had been presented. However, this method involves complicated symbolic expressions, and the end result requires finding the roots of high order polynomial, which must be carried out numerically. The practical approach for the solution of the direct problem consists in the numerical determination of displacement using the method of Newton–Raphson.

Newton–Raphson method: For numerical methods the initial estimation Z_0 is chosen at random. It is not a root of equation (3.4). However, there is some ΔZ , to which one can add Z and will get a root of the equation.

This can be written as follows:

$$\begin{aligned} W_i(Z + \Delta Z) &= W_i(x + \delta x, y + \delta y, z + \delta z, \alpha + \delta \alpha, \beta + \delta \beta, \gamma + \delta \gamma) \\ &= 0 \quad (i = 1, \dots, m) \end{aligned} \quad (3.5)$$

It is necessary to determine ΔZ . To do this, let's distribute the right side in Taylor expansion and get the linear approximation of the function:

$$\begin{aligned}
W_i(Z + \Delta Z) = W_i(Z) + \left(\frac{\partial W_i(Z)}{\partial x}\right) \delta x + \left(\frac{\partial W_i(Z)}{\partial y}\right) \delta y + \left(\frac{\partial W_i(Z)}{\partial z}\right) \delta z \\
+ \left(\frac{\partial W_i(Z)}{\partial \alpha}\right) \delta \alpha + \left(\frac{\partial W_i(Z)}{\partial \beta}\right) \delta \beta + \left(\frac{\partial W_i(Z)}{\partial \gamma}\right) \delta \gamma = 0
\end{aligned} \tag{3.6}$$

The equation (3.6) is a linear system, so we can write the Jacobian matrix J_{NR} or Newton–Raphson method. It looks like this:

$$J_{NR} = \begin{bmatrix} \frac{\partial W_1(Z)}{\partial x} & \dots & \frac{\partial W_1(Z)}{\partial \gamma} \\ \vdots & & \vdots \\ \frac{\partial W_m(Z)}{\partial x} & \dots & \frac{\partial W_m(Z)}{\partial \gamma} \end{bmatrix} \tag{3.7}$$

Beginning with the designated position Z_0 , the process for the step $k+1$ can be written as:

1. Solve $J_{NR} \Delta Z_k = -W(Z_k)$ for ΔZ_k :
$$\Delta Z_k = -J_{NR}^+ W(Z_k) \tag{3.8}$$
2. Then let $Z_{k+1} = Z_k + \Delta Z_k$
3. Iterate until: $\|\delta Z_k\| < \varepsilon$

Where $J_{NR}^+ = (J_{NR}^T J_{NR})^{-1} J_{NR}^T$ is a pseudo inverse of the matrix of Jacobi, $\delta(Z) = \{\delta x, \delta y, \delta z, \delta \alpha, \delta \beta, \delta \gamma\}$, ε is the user–set deviation.

The rate of convergence depends on the initial approximation Z_0 . In the subsequent movement of the platform, use of the previous solution as initial approximation often brings the solution to the proper one.

Inverse displacement analysis

Backward displacement analysis is to determine the length l_i of each of the cables and the known position of the moving platform. Compared to direct analysis, backward displacement analysis is simpler and easier. We can find a unique solution for each cable, if we know the position of the moving platform. From the equation (3.4) the length of each cable can be calculated with acquainted $(x, y, z, \alpha, \beta, \gamma)$:

$$l_i^2 = (b + Rq_i^0 - d_i)^T (b + Rq_i^0 - d_i) \quad (i = 1, \dots, m) \tag{3.9}$$

3.2.2 Velocity Analysis

The main task of the velocity analysis is to determine the correspondence between the velocity of the moving platform and the velocity of change of the cables length. The expression for the instantaneous kinematic connection between the velocity of the cable and the velocity of the platform is written as follows:

$$\dot{L} = J_{\chi} \dot{\chi} \quad (3.10)$$

Where,

$\dot{L} = \{\dot{l}_1, \dots, \dot{l}_m\}^T$: the vector of the velocity of change of the cable length,

J_{χ} : the Jacobian matrix, dependent on the coordinate system $\{0\}$,

$\dot{\chi} = \{v, \omega\}^T = \{\dot{x}, \dot{y}, \dot{z}, \omega_x, \omega_y, \omega_z\}^T$, v is the velocity vector of the platform, ω is the vector of angular velocity around the axes of the platform.

The transition from the angular velocity $\{\omega_x, \omega_y, \omega_z\}^T$ to the instantaneous values of the angles $\{\dot{\alpha}, \dot{\beta}, \dot{\gamma}\}$ can be written as follows:

$$\omega = \begin{Bmatrix} \omega_x \\ \omega_y \\ \omega_z \end{Bmatrix} = \begin{bmatrix} \cos\gamma\cos\beta & -\sin\gamma & 0 \\ \sin\gamma\cos\beta & \cos\gamma & 0 \\ -\sin\beta & 0 & 1 \end{bmatrix} \begin{Bmatrix} \dot{\alpha} \\ \dot{\beta} \\ \dot{\gamma} \end{Bmatrix} \quad (3.11)$$

Let's differentiate the equation (3.3) with respect to time and obtain:

$$\begin{aligned} \dot{l}_i &= \frac{d}{dt} \|l_i\| = \frac{1}{\|l_i\|} \frac{d}{dt} \left[\frac{1}{2} (l_i)^2 \right] = \frac{1}{2\|l_i\|} \frac{d}{dt} [(b + Rq_i^Q - d_i)^2] \\ &= \frac{1}{2\|l_i\|} \frac{d}{dt} [(b)^2 + (Rq_i^Q)^2 + (d_i)^2 + 2b^T Rq_i^Q - 2b^T d_i \\ &\quad - 2d_i^T Rq_i^Q] = \frac{1}{\|l_i\|} [(b + Rq_i^Q - d_i) \cdot v + (b - d_i)^T \dot{R}q_i^Q] \\ &= \frac{1}{\|l_i\|} [l_i \cdot v + (b - d_i) \cdot \dot{R}q_i^Q] \end{aligned} \quad (3.12)$$

Then we use the expression $\dot{R}q_i^Q = \omega \times Rq_i^Q$ and obtain:

$$\begin{aligned} (b - d_i) \cdot \dot{R}q_i^Q &= (b - d_i) \cdot [\omega \times Rq_i^Q] = \omega \cdot [Rq_i^Q \times (b - d_i)] \\ &= \omega \cdot [Rq_i^Q \times (b - d_i + Rq_i^Q)] = \omega \cdot [Rq_i^Q \times l_i] = \omega \cdot (-l_i \times Rq_i^Q) \end{aligned} \quad (3.13)$$

Where we use the next rules: $a \cdot (b \times c) = b \cdot (c \times a)$ and $(a \times b) = a \times (b + a)$.
Now the ratio between the rate of the cable and Cartesian rates are:

$$\dot{l}_i = \frac{1}{\|l_i\|} [l_i \cdot v + \omega \cdot (-l_i \times Rq_i^Q)] = [\hat{l}_i^T - (l_i \times Rq_i^Q)^T] \begin{Bmatrix} v \\ \omega \end{Bmatrix} \quad (3.14)$$

Where $\hat{l}_i^T = \frac{l_i}{\|l_i\|}$ is a unitary vector. Using the obtained expression it is possible to write the Jacobian matrix:

$$J_\chi = \begin{bmatrix} \hat{l}_1^T & -(l_1 \times Rq_1^Q)^T \\ \vdots & \vdots \\ \hat{l}_m^T & -(l_m \times Rq_m^Q)^T \end{bmatrix} = \begin{bmatrix} \hat{l}_1^T & -(l_1 \times q_1)^T \\ \vdots & \vdots \\ \hat{l}_m^T & -(l_m \times q_m)^T \end{bmatrix} \quad (3.15)$$

3.2.3 Acceleration Analysis

Acceleration analysis is connected with the definition of the ration of the translational acceleration of the cabled and the acceleration of the moving platform. Applying this analysis, we can determine the kinematic change of the cables length while the platform's moving along the predetermined trajectory. Linear acceleration of the cables can be obtained by differentiating in time the expression (3.10).

$$\ddot{L} = J_\chi \ddot{\chi} + \frac{d}{dt}(J_\chi) \dot{\chi} \quad (3.16)$$

Where,

$\ddot{L} = \{\ddot{l}_1, \dots, \ddot{l}_m\}$ is a vector of the cables accelerations.

$\ddot{\chi} = \{a \dot{\omega}\}^T = \{\ddot{x}, \ddot{y}, \ddot{z}, \dot{\omega}_x, \dot{\omega}_y, \dot{\omega}_z\}$ – a is an acceleration vector, and ω is the vector of the angular accelerations around the axis of the platform. Thus, the basic equation of acceleration is:

$$\ddot{L} = J_\chi \begin{Bmatrix} \ddot{x} \\ \vdots \\ \dot{\omega}_z \end{Bmatrix} + \left(\frac{\partial J_\chi}{\partial x} \dot{x} + \dots + \frac{\partial J_\chi}{\partial \gamma} \dot{\gamma} \right) \begin{Bmatrix} \dot{x} \\ \vdots \\ \omega_z \end{Bmatrix} \quad (3.17)$$

3.2.4 Kinematic Equations for Cable–Driven Robot

In the Figure 3.2 there is presented a cable–driven robot, whose mobile platform is attached to the body via four active cables, that is, D_1Q_1, D_2Q_2, D_3Q_3 and D_4Q_4 . The position of the platform is specified in the following manner – (x, y, φ) , where x and y are the coordinates, and φ is the angle of rotation of the coordinate system $\{Q\}$ around the Z axis.

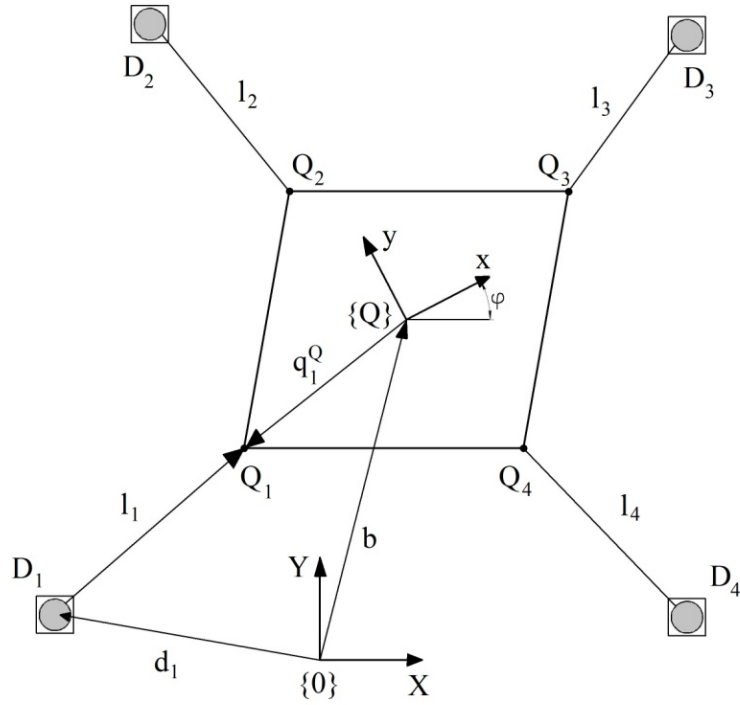

Figure 3.2. Kinematic chart of the cable-driven robot

Let's write down the equation of the closed-loop vector and get:

$$l_i = b + Rq_i^Q - d_i \quad (3.18)$$

$$l_i = \|l_i\| = \|b + Rq_i^Q - d_i\|$$

Where $b = (x, y)^T$ is the positioning vector of the point Q relatively to the coordinate system $\{0\}$, and $R = \begin{bmatrix} \cos\varphi & -\sin\varphi \\ \sin\varphi & \cos\varphi \end{bmatrix}$ describes the platform orientation relatively to the coordinate system $\{0\}$ in the plane.

Inverse kinematic for cable-driven robot.

By expanding the equation (3.18) the length l_i of each of the cables can be calculated from the equation (3.19):

$$\begin{aligned} l_i^2 = & x^2 + y^2 + q_{i,x}^{Q2} + d_{i,y}^2 + 2x(q_{i,x}^Q \cos\varphi - q_{i,y}^Q \sin\varphi - d_{i,x}) \\ & + 2y(q_{i,x}^Q \sin\varphi - q_{i,y}^Q \cos\varphi - d_{i,y}) - 2(q_{i,x}^Q d_{i,x} + q_{i,y}^Q d_{i,y})\cos\varphi \\ & + 2(q_{i,x}^Q d_{i,x} - q_{i,y}^Q d_{i,y})\sin\varphi \end{aligned} \quad (3.19)$$

Velocity analysis for cable-driven robot.

For the cable-driven robot velocity analysis can be written as follows:

$$l_i = b + Rq_i^Q - d_i$$

$$\begin{Bmatrix} l_{i,x} \\ l_{i,y} \end{Bmatrix} = \begin{Bmatrix} x \\ y \end{Bmatrix} + \begin{bmatrix} \cos\varphi & -\sin\varphi \\ \sin\varphi & \cos\varphi \end{bmatrix} \begin{Bmatrix} q_{i,x}^Q \\ q_{i,y}^Q \end{Bmatrix} - \begin{Bmatrix} d_{i,x} \\ d_{i,y} \end{Bmatrix} \quad (3.20)$$

Differentiating the equation (3.20) in time, we get:

$$\dot{l}_{i,x} = \dot{x} - (q_{i,x}^Q \sin\varphi + q_{i,y}^Q \cos\varphi)\dot{\varphi}$$

$$\dot{l}_{i,y} = \dot{y} + (q_{i,x}^Q \cos\varphi - q_{i,y}^Q \sin\varphi)\dot{\varphi} \quad (3.21)$$

It is known that $l_i^2 = l_{i,x}^2 + l_{i,y}^2$. Let's differentiate both sides of this equation in time:

$$\dot{l}_i^2 = \dot{l}_{i,x}^2 + \dot{l}_{i,y}^2$$

$$2l_i * \dot{l}_i = 2l_{i,x} * \dot{l}_{i,x} + 2l_{i,y} * \dot{l}_{i,y} \quad (3.22)$$

Let's divide both sides of the equation (3.22) on $2l_i$ and get the following:

$$\dot{l}_i = \frac{l_{i,x}}{l_i} * \dot{l}_{i,x} + \frac{l_{i,y}}{l_i} * \dot{l}_{i,y} \quad (3.23)$$

Substitute in the equation (3.23) the obtained equations (3.21) and get the following equation:

$$\dot{l}_i = \frac{l_{i,x}}{l_i} * (\dot{x} - (q_{i,x}^Q \sin\varphi + q_{i,y}^Q \cos\varphi)\dot{\varphi}) + \frac{l_{i,y}}{l_i} * (\dot{y} + (q_{i,x}^Q \cos\varphi - q_{i,y}^Q \sin\varphi)\dot{\varphi})$$

Disclose the brackets and get:

$$\begin{aligned} \dot{l}_i &= \frac{l_{i,x}}{l_i} * \dot{x} - \frac{l_{i,x}}{l_i} * (q_{i,x}^Q \sin\varphi + q_{i,y}^Q \cos\varphi)\dot{\varphi} + \frac{l_{i,y}}{l_i} * \dot{y} + \frac{l_{i,y}}{l_i} * (q_{i,x}^Q \cos\varphi - q_{i,y}^Q \sin\varphi)\dot{\varphi} \\ \dot{l}_i &= \frac{l_{i,x}}{l_i} * \dot{x} + \frac{l_{i,y}}{l_i} * \dot{y} + \dot{\varphi} \\ &\quad * \left(\frac{l_{i,y}}{l_i} * (q_{i,x}^Q \cos\varphi - q_{i,y}^Q \sin\varphi) - \frac{l_{i,x}}{l_i} * (q_{i,x}^Q \sin\varphi + q_{i,y}^Q \cos\varphi) \right) \end{aligned} \quad (3.24)$$

The obtained expression (3.24) can be rewritten as follows:

$$\dot{l}_i = J_{i,x}\dot{x} + J_{i,y}\dot{y} + J_{i,\varphi}\dot{\varphi} \quad (3.25)$$

Let's write the equation (3.25) in the matrix form:

$$\begin{pmatrix} \dot{l}_1 \\ \dot{l}_2 \\ \dot{l}_3 \\ \dot{l}_4 \end{pmatrix} = \begin{bmatrix} J_{1,x} & J_{1,y} & J_{1,\varphi} \\ J_{2,x} & J_{2,y} & J_{2,\varphi} \\ J_{3,x} & J_{3,y} & J_{3,\varphi} \\ J_{4,x} & J_{4,y} & J_{4,\varphi} \end{bmatrix} \begin{pmatrix} \dot{x} \\ \dot{y} \\ \dot{\varphi} \end{pmatrix} = J_\chi \begin{pmatrix} \dot{x} \\ \dot{y} \\ \dot{\varphi} \end{pmatrix} \quad (3.26)$$

J_χ is the Jacobian matrix.

The velocities coefficients $J_{i,x}, J_{i,y}, J_{i,\varphi}$ have the form:

$$J_{i,x} = \frac{l_{i,x}}{l_i} \quad (3.27)$$

$$J_{i,y} = \frac{l_{i,y}}{l_i} \quad (3.28)$$

$$J_{i,\varphi} = \frac{l_{i,y}}{l_i} * (q_{i,x}^Q \cos\varphi - q_{i,y}^Q \sin\varphi) - \frac{l_{i,x}}{l_i} * (q_{i,x}^Q \sin\varphi + q_{i,y}^Q \cos\varphi) \quad (3.29)$$

Acceleration analysis for cable-driven robot.

Using the equations (3.18), (3.19) and (3.27)–(3.29), we can write the equations of accelerations:

$$\dot{L} = \begin{pmatrix} \dot{l}_1 \\ \dot{l}_2 \\ \dot{l}_3 \\ \dot{l}_4 \end{pmatrix} = J_\chi \begin{pmatrix} \dot{x} \\ \dot{y} \\ \dot{\varphi} \end{pmatrix} \quad (3.30)$$

$$\ddot{L} = \begin{pmatrix} \ddot{l}_1 \\ \ddot{l}_2 \\ \ddot{l}_3 \\ \ddot{l}_4 \end{pmatrix} = J_\chi \begin{pmatrix} \ddot{x} \\ \ddot{y} \\ \ddot{\varphi} \end{pmatrix} + \left(\frac{\partial J_\chi}{\partial x} \dot{x} + \frac{\partial J_\chi}{\partial y} \dot{y} + \frac{\partial J_\chi}{\partial \varphi} \dot{\varphi} \right) \begin{pmatrix} \dot{x} \\ \dot{y} \\ \dot{\varphi} \end{pmatrix} \quad (3.31)$$

$$\frac{\partial J_\chi}{\partial x} = \begin{bmatrix} \frac{\partial J_{1,x}}{\partial x} & \frac{\partial J_{1,y}}{\partial x} & \frac{\partial J_{1,\varphi}}{\partial x} \\ \frac{\partial J_{2,x}}{\partial x} & \frac{\partial J_{2,y}}{\partial x} & \frac{\partial J_{2,\varphi}}{\partial x} \\ \frac{\partial J_{3,x}}{\partial x} & \frac{\partial J_{3,y}}{\partial x} & \frac{\partial J_{3,\varphi}}{\partial x} \\ \frac{\partial J_{4,x}}{\partial x} & \frac{\partial J_{4,y}}{\partial x} & \frac{\partial J_{4,\varphi}}{\partial x} \end{bmatrix} \quad (3.32)$$

$$\frac{\partial J_x}{\partial y} = \begin{bmatrix} \frac{\partial J_{1,x}}{\partial y} & \frac{\partial J_{1,y}}{\partial y} & \frac{\partial J_{1,\varphi}}{\partial y} \\ \frac{\partial J_{2,x}}{\partial y} & \frac{\partial J_{2,y}}{\partial y} & \frac{\partial J_{2,\varphi}}{\partial y} \\ \frac{\partial J_{3,x}}{\partial y} & \frac{\partial J_{3,y}}{\partial y} & \frac{\partial J_{3,\varphi}}{\partial y} \\ \frac{\partial J_{4,x}}{\partial y} & \frac{\partial J_{4,y}}{\partial y} & \frac{\partial J_{4,\varphi}}{\partial y} \end{bmatrix} \quad (3.33)$$

$$\frac{\partial J_x}{\partial \varphi} = \begin{bmatrix} \frac{\partial J_{1,x}}{\partial \varphi} & \frac{\partial J_{1,y}}{\partial \varphi} & \frac{\partial J_{1,\varphi}}{\partial \varphi} \\ \frac{\partial J_{2,x}}{\partial \varphi} & \frac{\partial J_{2,y}}{\partial \varphi} & \frac{\partial J_{2,\varphi}}{\partial \varphi} \\ \frac{\partial J_{3,x}}{\partial \varphi} & \frac{\partial J_{3,y}}{\partial \varphi} & \frac{\partial J_{3,\varphi}}{\partial \varphi} \\ \frac{\partial J_{4,x}}{\partial \varphi} & \frac{\partial J_{4,y}}{\partial \varphi} & \frac{\partial J_{4,\varphi}}{\partial \varphi} \end{bmatrix} \quad (3.34)$$

Where,

$$\frac{\partial J_{i,x}}{\partial x} = + \frac{l_{i,y}^2}{l_i^3}$$

$$\frac{\partial J_{i,y}}{\partial y} = - \frac{l_{i,x} l_{i,y}}{l_i^3}$$

$$\frac{\partial J_{i,\varphi}}{\partial y} = - \frac{l_{i,y} (q_{i,x} l_{i,x} + q_{i,y} l_{i,y})}{l_i^3}$$

$$\frac{\partial J_{i,x}}{\partial y} = - \frac{l_{i,x} l_{i,y}}{l_i^3}$$

$$\frac{\partial J_{i,y}}{\partial y} = + \frac{l_{i,y}^2}{l_i^3}$$

$$\frac{\partial J_{i,\varphi}}{\partial y} = + \frac{l_{i,x} (q_{i,x} l_{i,x} + q_{i,y} l_{i,y})}{l_i^3}$$

$$\frac{\partial J_{i,x}}{\partial \varphi} = - \frac{l_{i,y} (q_{i,x} l_{i,x} + q_{i,y} l_{i,y})}{l_i^3}$$

$$\frac{\partial J_{i,y}}{\partial \varphi} = + \frac{l_{i,x} (q_{i,x} l_{i,x} + q_{i,y} l_{i,y})}{l_i^3}$$

$$\frac{\partial J_{i,\varphi}}{\partial \varphi} = -\frac{(q_{i,x}l_{i,x} + q_{i,y}l_{i,y})^2}{l_i^3} + \frac{q_i^2}{l_i} - \left(\frac{q_{i,x}l_{i,x}}{l_i} + \frac{q_{i,y}l_{i,y}}{l_i} \right)$$

Summary: in this chapter there was presented the kinematic analysis of the cable-driven robot. There was given the concept of the direct displacement analysis, explained Newton-Raphson method and stated its purpose. As well in this chapter there was presented the inverse displacement analysis with the following derivation of the equations to determine velocities and accelerations. At the end of the Chapter there was presented the derivation of the formula for the cable-driven robot; this thesis is devoted to the design of this robot. The derived formulas can be used in the future for the design and study of cable-driven robots with various numbers of cables.

4. TENSION ANALYSIS

This Chapter describes the tension analysis. Under static conditions the cables tension is a very important issue for the terms of kinetostatical analysis of the cable-driven robot.

This section is devoted to the cable tension analysis of the cable-driven robot under static conditions. For static balance it is necessary that the sum of the external forces and moments operating on the platform via the cables was equal to the resultant external wrench exerted on the environment. In the Figure 4.1 there is shown the chart of the moving platform of the cable-driven robot.

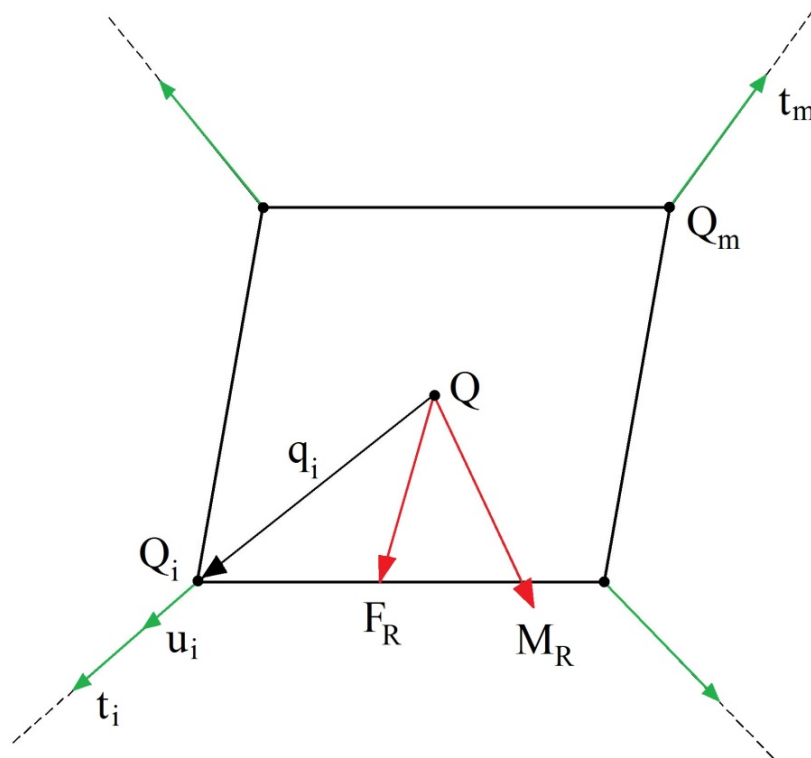

Figure 4.1. The chart of the free body of the platform

The state of static balance is written as:

$$\sum_{i=1}^m t_i + F_R = 0 \quad (4.1)$$

$$\sum_{i=1}^m q_i \times t_i + M_R = \sum_{i=1}^m (Rq_i^Q) \times t_i + M_R = 0 \quad (4.2)$$

In the equations (4.1) and (4.2) t_i is the tension of each cable. To simplify:

$$u_i = -\hat{l}_i = -\frac{l_i}{\|l_i\|} \Rightarrow t_i = t_i u_i = -t_i \frac{l_i}{\|l_i\|} \quad (4.3)$$

R is the rotation matrix that defines the position of the point Q relatively to 0; F_R and M_R are the resultant vectors of force and moment respectively (together they form a wrench) operating on the platform. Let's substitute the equation (4.3) in the equations (4.1) and (4.2) and get:

$$ST = W_R \quad (4.4)$$

Where,

$S = \begin{bmatrix} u_1 & \cdots & u_m \\ q_1 \times u_1 & \cdots & q_m \times u_m \end{bmatrix}$ is the structure matrix

$T = \{t_1, \dots, t_m\}^T$ is the vector of the cables tension

$W_R = -\begin{Bmatrix} F_R \\ M_R \end{Bmatrix}$ is the external wrench

It is worth noting that $S = J_\chi^T$ (where J_χ is the Jacobian matrix described in the equation (3.15)).

For the cable-driven robots with extraexcitation the system is under restriction, which means that there is an infinite solution for the cable tension vector T to provide the necessary wrench W_R .

In the case $m > n$ the solution to the tension can be written using the pseudo-inverse matrix; as a result we get the known homogeneous solution to the cables tension:

$$T = S^+ W_R + (I - S^+ S)G \quad (4.5)$$

Where,

$S^+ = S^T (SS^T)^{-1}$ is a pseudo-inversion of the structure matrix S

I is the identity matrix

$G = \{g_1, \dots, g_m\}^T$ is an arbitrary column vector

In the equation (4.5) the first expression $S^+ W_R$ is a specific solution to obtain the desired wrench W_R .

For the cable–driven robot with one degree of redundancy (as in our case), the method of positive cable tension [43] can be applied to determine the static workspace. Let’s write a formula equivalent to (4.5) for this case:

$$T = S^+W_R + \mu N \quad (4.7)$$

Where the homogeneous solution is presented in the form of the main vector of the structure matrix ($N = \{n_1, \dots, n_m\}^T$), multiplied by an arbitrary value of μ .

The expression (4.7) in the matrix form is:

$$T = \begin{Bmatrix} t_1 \\ t_2 \\ t_3 \\ t_4 \end{Bmatrix} = \begin{Bmatrix} t_{Q1} \\ t_{Q2} \\ t_{Q3} \\ t_{Q4} \end{Bmatrix} + \mu \begin{Bmatrix} n_1 \\ n_2 \\ n_3 \\ n_4 \end{Bmatrix} \quad (4.8)$$

To provide the positive t_i tension on all the cables using this method, it is necessary and sufficient for all the components n_i of the main vector to have the same sign. This means that for a certain point, which is in a static workspace, each $n_i > 0$ or each $n_i < 0$. If one of these conditions is satisfied, independently of a particular solution, the value μ can be found from the equation (4.7). This ensures that all the cables tensions are positive when adding (or subtracting) another homogeneous solution. It is worth to note that there is required the strict inequality. If one or more $n_i = 0$, then there is no belonging to the static workspace. This method is quite simple, but effective, as there is no need to consider specific wrenches (this works for all possible wrenches). It should be noted that this method is used for planar and spatial cable–driven robots with one degree of excitation.

Summary: In this chapter there is presented the cables tension analysis in a static condition. But when the robot operates, there are still additional forces; therefore, next there will be presented the dynamic analysis for cable–driven robot.

5. DYNAMIC MODELING

This chapter describes the dynamic modeling for the cable-driven robot. Dynamic modeling is necessary to ensure more precise control during the robot's motion with high velocity and accelerations.

Dynamic analysis for the moving platform, motor and the system overall is presented in this chapter. For the cables it is assumed that they are weightless.

5.1 Dynamic Model of the Platform

This section describes the equations of dynamics using Newton's second law. The chart of the moving platform to simulate the dynamics is presented in the Figure 5.1.

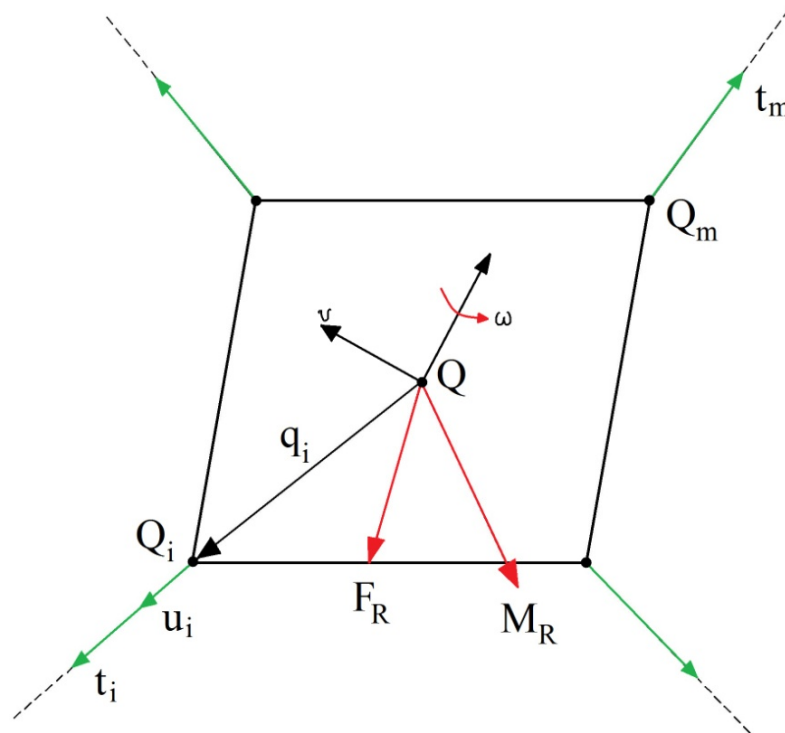

Figure 5.1. Chart of the moving platform

$$\sum t_i + m_l g + F_R = m_l \dot{v} \quad (5.1)$$

$$\sum q_i \times t_i + M_R = I_l \dot{\omega} + \omega \times (I_l \omega) \quad (5.2)$$

Where,

m_l is the mass of the platform

I_l is inertia tensor of the platform

g is gravitational acceleration

v, ω are velocity and angular acceleration

Let's combine the equations (5.1) and (5.2) in the matrix and get the dynamic equation for the platform:

$$ST = W \quad (5.3)$$

Where,

$S = \begin{bmatrix} u_1 & \cdots & u_m \\ q_1 \times u_1 & \cdots & q_m \times u_m \end{bmatrix}$ is the structure matrix

$T = \{t_1, \dots, t_m\}^T$ is the vector of the cables tensions

$W = \left\{ \begin{array}{l} m_l \dot{v} - m_l g - F_R \\ I_l \dot{\omega} + \omega \times (I_l \omega) - M_R \end{array} \right\}$ is dynamic wrench acting on the platform

The equation (5.3) is similar to the equation of the cable-driven robot statics (4.4), with the only difference that the W_R is replaced by W . This is the reason why the method described in the part 4, can be used to obtain the dynamics of the cables tension, provided that the dynamic terms are included in the dynamic wrench.

5.2 Dynamic Model of the Motor

This section is devoted to the dynamics of the motor shaft/coil for the cable. In the Figure 5.2 you can see the chart for the motor shaft/coil.

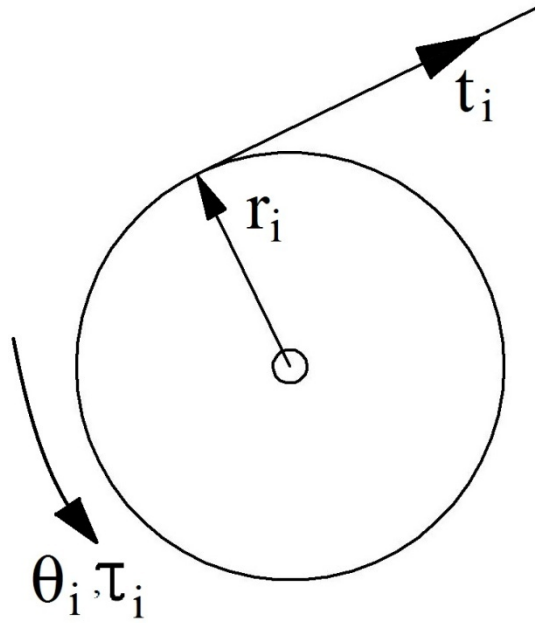

Figure 5.2. Chart of the motor/coils

The combined dynamic equation for the motor/coil can be written as follows [44]:

$$\tau_i - r_i t_i = J_i \ddot{\theta}_i + C_i \dot{\theta}_i \quad (5.4)$$

Where,

(J_i, C_i) are the combined rotational inertia and damping coefficient

r_i is the radius of the winding part of the coil

τ_i is the motor torque

Provided that the rotational torque of each motor is large enough to keep the cables taut, the equation (5.4) can be rewritten in the matrix form, expressing the cables tension as a function of the motors moments:

$$T = \frac{1}{r} (\tau - J\ddot{\theta} - C\dot{\theta}) \quad (5.5)$$

Where,

$$J = \text{diag}(J_1, \dots, J_m)$$

$$C = \text{diag}(C_1, \dots, C_m)$$

$$r = \text{diag}(r_1, \dots, r_m)$$

$$T = [t_1, \dots, t_m]^T$$

$$\tau = [\tau_1, \dots, \tau_m]^T$$

$\theta = [\theta_1, \dots, \theta_m]^T$ is the vector of the angular position of the motor

5.3 Dynamic Model of the System

Dynamic model of the system is a combination of the dynamic motion equations of the platform and motor. To obtain the expression connecting the rotation angles of the motor θ_i and the position of the platform Z , we define all the θ_i as zero when the center of the platform is at the beginning of the coordinate system $\{0\}$ with zero rotation. In this situation, after the beginning of the movement, the angle change θ_i at some of the motors will cause a negative change Δl_i of the cables length, at the others – positive [40].

$$r_i \theta_i = -\Delta l_i \quad (5.6)$$

The change of the cable length $\Delta l_i = l_i - l_{i0}$, where l_i is the current cable length and l_{i0} is the initial cable length.

$$l_i = \|b + Rq_i^Q - d_i\| \quad (5.7)$$

$$l_{i0} = \|q_i - d_i\| \quad (5.8)$$

$$\theta = \begin{Bmatrix} \theta_1(Z) \\ \vdots \\ \theta_m(Z) \end{Bmatrix} = \frac{1}{r} \begin{Bmatrix} \|q_1 - d_1\| - \|b + Rq_1^Q - d_1\| \\ \vdots \\ \|q_m - d_m\| - \|b + Rq_m^Q - d_m\| \end{Bmatrix} \quad (5.9)$$

The derived functions of the equation (5.9) look in the following way:

$$\dot{\theta} = \frac{\partial \theta}{\partial Z} \dot{Z} \quad (5.10)$$

$$\ddot{\theta} = \frac{d}{dt} \left(\frac{\partial \theta}{\partial Z} \right) \dot{Z} + \left(\frac{\partial \theta}{\partial Z} \right) \ddot{Z} \quad (5.11)$$

Where $\left(\frac{\partial \theta}{\partial Z} \right)$ can be easily found from the equation (5.9). Let's substitute the equations (5.10) and (5.11) into the equation (5.5):

$$T = \frac{1}{r} \left(\tau - J \left(\frac{d}{dt} \left(\frac{\partial \theta}{\partial Z} \right) \dot{Z} + \left(\frac{\partial \theta}{\partial Z} \right) \ddot{Z} \right) - C \left(\frac{\partial \theta}{\partial Z} \dot{Z} \right) \right) \quad (5.12)$$

Combining the equations (5.3) and (5.12), we obtain the general equation of the dynamic motion:

$$M_{eq}\ddot{Z} + N(Z, \dot{Z}) = S\tau \quad (5.13)$$

Where M_e is the equivalent inertia matrix $N(Z, \dot{Z})$ of the nonlinear expression:

$$M_{eq} = SJ \left(\frac{\partial \theta}{\partial Z} \right) + r \begin{bmatrix} m_l I_{3 \times 3} & 0 \\ 0 & I_l \end{bmatrix} \quad (5.14)$$

$$N(Z, \dot{Z}) = S \left(J \frac{d}{dt} \left(\frac{\partial \theta}{\partial Z} \right) + C \left(\frac{\partial \theta}{\partial Z} \right) \right) \dot{Z} + r \left\{ \begin{array}{l} -m_l g - F_R \\ \omega \times (I_l \omega) - M_R \end{array} \right\} \quad (5.15)$$

5.4 Dynamic Equations for Cable-Driven Robot

Dynamic of the platform of CDR:

$$l_i = \sqrt{(x + q_{i,x}^Q \cos \varphi - q_{i,y}^Q \sin \varphi - d_{i,x})^2 + (y + q_{i,x}^Q \sin \varphi + q_{i,y}^Q \cos \varphi - d_{i,y})^2}$$

$$l_{i,x} = (x + q_{i,x}^Q \cos \varphi - q_{i,y}^Q \sin \varphi - d_{i,x})$$

$$l_{i,y} = (y + q_{i,x}^Q \sin \varphi + q_{i,y}^Q \cos \varphi - d_{i,y})$$

$$l_{i,0} = \sqrt{(q_{i,x}^Q - d_{i,x})^2 + (q_{i,y}^Q - d_{i,y})^2}$$

$$Z = \{x \ y \ \varphi\}^T$$

$$\theta = \begin{Bmatrix} \theta_1 \\ \theta_2 \\ \theta_3 \\ \theta_4 \end{Bmatrix} = \frac{1}{r} \begin{Bmatrix} l_{1,0} - l_1 \\ l_{2,0} - l_2 \\ l_{3,0} - l_3 \\ l_{4,0} - l_4 \end{Bmatrix}$$

$$\dot{\theta} = \begin{Bmatrix} \dot{\theta}_1 \\ \dot{\theta}_2 \\ \dot{\theta}_3 \\ \dot{\theta}_4 \end{Bmatrix} = \begin{bmatrix} \frac{\partial \theta_1}{\partial x} & \frac{\partial \theta_1}{\partial y} & \frac{\partial \theta_1}{\partial \varphi} \\ \vdots & \vdots & \vdots \\ \frac{\partial \theta_4}{\partial x} & \frac{\partial \theta_4}{\partial y} & \frac{\partial \theta_4}{\partial \varphi} \end{bmatrix} \begin{Bmatrix} \dot{x} \\ \dot{y} \\ \dot{\varphi} \end{Bmatrix}$$

$$\frac{\partial \theta_i}{\partial x} = \frac{-1}{r_i l_i} (l_{i,x})$$

$$\frac{\partial \theta_i}{\partial y} = \frac{-1}{r_i l_i} (l_{i,y})$$

$$\frac{\partial \theta_i}{\partial \varphi} = \frac{-1}{r_i l_i} [(-q_{i,x}^Q \sin \varphi - q_{i,y}^Q \cos \varphi)(l_{i,x}) + (q_{i,x}^Q \cos \varphi - q_{i,y}^Q \sin \varphi)(l_{i,y})]$$

$$\ddot{\theta} = \begin{Bmatrix} \ddot{\theta}_1 \\ \ddot{\theta}_2 \\ \ddot{\theta}_3 \\ \ddot{\theta}_4 \end{Bmatrix} = [S_x(\dot{x}) + S_y(\dot{y}) + S_\varphi(\dot{\varphi})] \begin{Bmatrix} \dot{x} \\ \dot{y} \\ \dot{\varphi} \end{Bmatrix} + \begin{bmatrix} \frac{\partial \theta_1}{\partial x} & \frac{\partial \theta_1}{\partial y} & \frac{\partial \theta_1}{\partial \varphi} \\ \vdots & \vdots & \vdots \\ \frac{\partial \theta_4}{\partial x} & \frac{\partial \theta_4}{\partial y} & \frac{\partial \theta_4}{\partial \varphi} \end{bmatrix} \begin{Bmatrix} \ddot{x} \\ \ddot{y} \\ \ddot{\varphi} \end{Bmatrix}$$

$$S_x = \begin{bmatrix} \frac{\partial}{\partial x} \left(\frac{\partial \theta_1}{\partial x} \right) & \frac{\partial}{\partial x} \left(\frac{\partial \theta_1}{\partial y} \right) & \frac{\partial}{\partial x} \left(\frac{\partial \theta_1}{\partial \varphi} \right) \\ \vdots & \vdots & \vdots \\ \frac{\partial}{\partial x} \left(\frac{\partial \theta_4}{\partial x} \right) & \frac{\partial}{\partial x} \left(\frac{\partial \theta_4}{\partial y} \right) & \frac{\partial}{\partial x} \left(\frac{\partial \theta_4}{\partial \varphi} \right) \end{bmatrix}$$

$$\frac{\partial}{\partial x} \left(\frac{\partial \theta_i}{\partial x} \right) = \frac{1}{r_i l_i} \left[\frac{1}{l_i^2} (l_{i,x})^2 - 1 \right]$$

$$\frac{\partial}{\partial x} \left(\frac{\partial \theta_i}{\partial y} \right) = \frac{1}{r_i l_i} \left[\frac{1}{l_i^2} (l_{i,x})(l_{i,y}) \right]$$

$$\frac{\partial}{\partial x} \left(\frac{\partial \theta_i}{\partial \varphi} \right) = \frac{1}{r_i l_i} \left\{ \frac{l_{i,x}}{l_i^2} [(-q_{i,x}^Q \sin \varphi - q_{i,y}^Q \cos \varphi)(l_{i,x}) + (q_{i,x}^Q \cos \varphi - q_{i,y}^Q \sin \varphi)(l_{i,y})] \right. \\ \left. + (q_{i,x}^Q \sin \varphi + q_{i,y}^Q \cos \varphi) \right\}$$

$$S_y = \begin{bmatrix} \frac{\partial}{\partial y} \left(\frac{\partial \theta_1}{\partial x} \right) & \frac{\partial}{\partial y} \left(\frac{\partial \theta_1}{\partial y} \right) & \frac{\partial}{\partial y} \left(\frac{\partial \theta_1}{\partial \varphi} \right) \\ \vdots & \vdots & \vdots \\ \frac{\partial}{\partial y} \left(\frac{\partial \theta_4}{\partial x} \right) & \frac{\partial}{\partial y} \left(\frac{\partial \theta_4}{\partial y} \right) & \frac{\partial}{\partial y} \left(\frac{\partial \theta_4}{\partial \varphi} \right) \end{bmatrix}$$

$$\frac{\partial}{\partial y} \left(\frac{\partial \theta_i}{\partial x} \right) = \frac{1}{r_i l_i} \left[\frac{1}{l_i^2} (l_{i,x})(l_{i,y}) \right]$$

$$\frac{\partial}{\partial y} \left(\frac{\partial \theta_i}{\partial y} \right) = \frac{1}{r_i l_i} \left[\frac{1}{l_i^2} (l_{i,y})^2 - 1 \right]$$

$$\frac{\partial}{\partial y} \left(\frac{\partial \theta_i}{\partial \varphi} \right) = \frac{1}{r_i l_i} \left\{ \frac{l_{i,y}}{l_i^2} [(-q_{i,x}^Q \sin \varphi - q_{i,y}^Q \cos \varphi)(l_{i,x}) + (q_{i,x}^Q \cos \varphi - q_{i,y}^Q \sin \varphi)(l_{i,y})] \right. \\ \left. - (q_{i,x}^Q \cos \varphi - q_{i,y}^Q \sin \varphi) \right\}$$

$$S_\varphi = \begin{bmatrix} \frac{\partial}{\partial \varphi} \left(\frac{\partial \theta_1}{\partial x} \right) & \frac{\partial}{\partial \varphi} \left(\frac{\partial \theta_1}{\partial y} \right) & \frac{\partial}{\partial \varphi} \left(\frac{\partial \theta_1}{\partial \varphi} \right) \\ \vdots & \vdots & \vdots \\ \frac{\partial}{\partial \varphi} \left(\frac{\partial \theta_4}{\partial x} \right) & \frac{\partial}{\partial \varphi} \left(\frac{\partial \theta_4}{\partial y} \right) & \frac{\partial}{\partial \varphi} \left(\frac{\partial \theta_4}{\partial \varphi} \right) \end{bmatrix}$$

$$\frac{\partial}{\partial \varphi} \left(\frac{\partial \theta_i}{\partial x} \right) = \frac{1}{r_i l_i} \left\{ \frac{1}{l_i^2} [(-q_{i,x}^Q \sin \varphi - q_{i,y}^Q \cos \varphi)(l_{i,x})^2 + (q_{i,x}^Q \cos \varphi - q_{i,y}^Q \sin \varphi)(l_{i,y})^2] \right. \\ \left. + (q_{i,x}^Q \sin \varphi + q_{i,y}^Q \cos \varphi) \right\}$$

$$\frac{\partial}{\partial \varphi} \left(\frac{\partial \theta_i}{\partial y} \right) = \frac{1}{r_i l_i} \left\{ \frac{l_{i,y}}{l_i^2} [(-q_{i,x}^Q \sin \varphi - q_{i,y}^Q \cos \varphi)(l_{i,x}) + (q_{i,x}^Q \cos \varphi - q_{i,y}^Q \sin \varphi)(l_{i,y})] \right. \\ \left. - (q_{i,x}^Q \cos \varphi - q_{i,y}^Q \sin \varphi) \right\}$$

$$\frac{\partial}{\partial \varphi} \left(\frac{\partial \theta_i}{\partial \varphi} \right) = \frac{1}{r_i l_i} \left\{ \frac{l_{i,x}}{l_i^2} [(-q_{i,x}^Q \sin \varphi - q_{i,y}^Q \cos \varphi)(l_{i,x}) + (q_{i,x}^Q \cos \varphi - q_{i,y}^Q \sin \varphi)(l_{i,y})] \right. \\ \left. - q_{i,y}^Q \sin \varphi \right\} + (-q_{i,x}^Q \sin \varphi - q_{i,y}^Q \cos \varphi) + (q_{i,x}^Q \cos \varphi - q_{i,y}^Q \sin \varphi)(l_{i,y})$$

Dynamics of the motor:

$$\begin{bmatrix} J_1 & & 0 \\ & \ddots & \\ 0 & & J_4 \end{bmatrix} \begin{Bmatrix} \ddot{\theta}_1 \\ \ddot{\theta}_2 \\ \ddot{\theta}_3 \\ \ddot{\theta}_4 \end{Bmatrix} + \begin{bmatrix} C_1 & & 0 \\ & \ddots & \\ 0 & & C_4 \end{bmatrix} \begin{Bmatrix} \dot{\theta}_1 \\ \dot{\theta}_2 \\ \dot{\theta}_3 \\ \dot{\theta}_4 \end{Bmatrix} = \begin{Bmatrix} \tau_1 \\ \tau_2 \\ \tau_3 \\ \tau_4 \end{Bmatrix} - \begin{bmatrix} r_1 & & 0 \\ & \ddots & \\ 0 & & r_4 \end{bmatrix} \begin{Bmatrix} t_1 \\ t_2 \\ t_3 \\ t_4 \end{Bmatrix}$$

Summary: This chapter presents a dynamic analysis separately for the moving platform, for the motor and for the system overall. There is also presented the dynamics of the cable-driven robot, which the thesis is devoted to. The obtained expressions can be used for designing other similar systems.

6. PROTOTYPING AND CONTROL

This chapter is devoted to a description of the programs used for the prototype design, calculations and writing of the control system to demonstrate the principles of the moving platform motions. There are also described the equipment and materials involved in building a real model installation.

6.1 Software

To implement three-dimensional modeling, making complex mathematical calculations and programming of electronic components in this work there was used the modern equipment of high level.

For three-dimensional design there was selected the software SolidWorks, which is available for use in the computer labs of the Department of Mechatronics. SolidWorks is a program that combines the whole complex of abilities needed in the engineering and other fields. It allows implementing the design of three-dimensional models and assemblies from any number of parts. These parts and assemblies can be used in the future for the quick creation of drawings. In addition, the capabilities of the program allow one to record animations of assemblies, to produce the strength analysis, etc. The benefit of using SolidWorks is also the fact that it has a simple and clear interface that facilitates rapid mastering.

Another advantage of this program can be considered the ability to work with different data formats, which allows one to access ready-made products from other design systems or vice versa to save data so that one can open them in other programs. SolidWorks is one of the best tools for engineering design, which is why we selected this program [45].

The following software, which was selected for the implementation of complex mathematical operations, is MATLAB.

MATLAB is a high-level language and interactive environment for programming, numerical calculations and visualization of results [46]. With its help it is possible to analyze various data, to develop algorithms, to create models and applications. Built-in math functions, tools, language – all these allow one to explore different approaches and obtain the solution faster than using electronic work sheets or other traditional programming languages.

A huge number of engineers and scientists in the world use MATLAB as an environment for technical computing.

MATLAB has the following key features:

- High-level programming language, independent of the platform and oriented to matrix computations and the development of algorithms;
- Convenient environment for code development, files and data control;
- Availability of linear algebra functions, statistics, the possible Fourier analysis, solution of differential equations, etc.;
- Opportunities of imaging, two – and three-dimensional graphics;
- Built-in tools for user interface development and creating complete applications for MATLAB;
- Tools of integration with C/C++, code inheritance, ActiveX technologies.

Due to the availability of great opportunities in mathematics and high computing speed, MATLAB was chosen as the environment for writing the software for mathematical calculations. It is also worth noting the possible combination of MATLAB work with the controllers of the control systems, which is an advantage when combining the computation environment and control environment.

Another software package that has been involved in the work is the programming environment of Arduino controllers.

The programming environment of cards with the microcontrollers Arduino is a very handy tool [47]. It is possible to identify such benefits as clear and simple programming language, the availability of libraries with a large set of functions, which greatly simplify writing codes for different operations, depending on the connected equipment to the card. It is worth noting that the card with the Arduino microcontrollers are one of the most common, so there are many video tutorials, articles and examples which significantly simplify the introduction and study of this product. Due to the advantages mentioned above as well as full availability of this product, it was decided to use the cards with the Arduino microcontrollers.

6.2 Field of Application of the Designed Cable–Driven Robot

The basic idea of the future application of the designed cable–driven robot is a mobile observing system. Due to the low mass of the moving platform and the possible use of surveillance cameras, the implementation of motion will require motors of small size, which means a low level of noise, and the flexibility of the design of the cable–driven robots allow one to install such a system in the areas of different shapes, while the changes in the control system and calculations will not be very great.

6.3 Equipment and Components

This section describes the electronic components used to implement movement and control, materials and components to build a complete design of a cable–driven robot, as well as the equipment for possible future use.

6.3.1 Electronic Components

Card with the microcontroller: the first important element for the implementation of the control system is the card with the microcontroller. We selected an analogue of Arduino Leonardo and it is called Itearduino Leonardo. It is almost indistinguishable from the original and was chosen because it has special inputs/outputs for connection of servo motors. The card is shown in the Figure 6.1.

Arduino is an open hardware programmable platform for work with various physical objects and is a simple card with a microcontroller and a special development environment for writing software of the microcontroller. It can be used to develop interactive systems with different sensors and switches, systems for controlling indicator lights, motors, and other devices [47].

Itearduino Leonardo is a card with a microcontroller based on the ATmega32u4 [48]. It has 20 digital inputs/outputs, crystal oscillator 16 MHz, micro USB connector, power connector, ICSP connector and a reset button. To work with this card one need to connect it to the computer via the USB port using the cable, or the use of alternative power sources, such as battery or power supply via special power supply units.

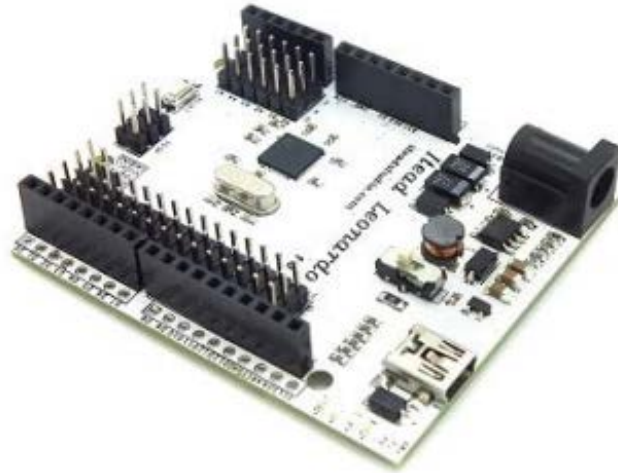

Figure 6.1. Card Iteduino Leonardo [48]

Table 6.1. Specifications

| | |
|---------------------------|---------------------------|
| Microprocessor | ATmega32U4 |
| PCB size | 68.58mm X 58.42mm X 1.6mm |
| Indicators | Power, TX, RX, L |
| Power supply(recommended) | 7–23V DC |
| Power supply(limits) | 23 VDC (max) |
| Communication Protocol | UART, SPI, IIC |
| Clock Speed | 16MHZ |

Table 6.2. Electrical Characteristics

| Specification | Min | Type | Max | Unit |
|------------------------|-----|-------|-----|------|
| Input Voltage | 7 | – | 23 | VDC |
| Operating Voltage | – | 3,3/5 | – | VDC |
| DC Current per I/O Pin | – | 40 | – | mA |

The card Iteduino Leonardo has the characteristics, which are necessary for prototyping in this work. Its operating speed and capabilities are enough to control four motors simultaneous. Used programming environment is convenient and clear, what is also a

benefit of using. It is also important that this platform is available at price. That is why this card with a microcontroller was chosen to create a layout that demonstrates the principles of the cable-driven robot motions. To provide additional external power supply, there was chosen power supply, operating from the mains. It is presented in the Figure 6.2. This power supply has 6 positions of the applied voltage from 3 to 12 VDC.



Figure 6.2. Power supply [49]

Servo motors: Other important components of the cable-driven robot are the motors, due to them, the moving platform can move. In this work for prototyping there were selected servo motors of constant rotation. They were selected, because at the same power they had relatively low prices compared to other types of motors, what is important since the budget for the prototype was limited. Moreover, they are easily controlled, have good rate at speed and weight-carrying capacity. They include a built-in regulator that allows one to control the speed rate and eliminates the use of additional equipment for these purposes.

Despite the many advantages of servo drill, there was pinpointed a number of shortcomings for this model. We didn't manage to express the coefficient for the speed accurately to precisely position the platform, so it is possible only to show the principle of the platform motion. In the future, this problem can be solved by using another model of servo drills, or using other types of motors, as well as with the improvement of the control system.

The Figure 6.3 depicts the used servo motor.



Figure 6.3. Servo motor of continuous rotation [50]

Table 6.3. Technical characteristics of servo motor

| Type | DG S04NFSTD |
|--------------|----------------|
| Voltage | 4,8 – 6 V |
| Angular rate | 60 deg/ 0,15 s |
| Moment | 3,5 kg–cm |

As one can see from the table, the motor moment is equal to 3,5 kg–cm, or approximately 0,34 Nm. The angular speed can be translated in the linear one:

$$v = \omega * r = \frac{60 * \pi}{180 * 0,15} * 0,025 = 0,175 \left(\frac{m}{s}\right) \quad (6.1)$$

Where,

v is a linear velocity

ω is an angular rate

r is a radius of the coil, which is equal to 0,025 (m)

It turns out that the maximum speed is 0,175 meter for 1 second.

The formula for the distance can be written as follows:

$$S = \frac{1}{2} * at^2 \quad (6.2)$$

Where S is the distance, a is acceleration and t is time.

As a result of the formula (6.2) we can obtain the acceleration:

$$a = \frac{2 * S}{t^2} = \frac{2 * 0,175}{1^2} = 0,35 \left(\frac{m}{s^2}\right) \quad (6.3)$$

To raise the mass $m=0.5$ kg, it is necessary to apply the force $F=ma$:

$$F = ma = 0,5 * 0,35 = 0,175(N) \quad (6.4)$$

It is also necessary to overcome the gravity force $mg=5(N)$.

As it has already been mentioned, the coil radius is $r=0,025(m)$, here we obtain the moment essential to work with the load of $m=0,5$ kg, which is equal to:

$$T = Fr = (0,175 + 5) * 0,025 = 0,13(N * m) \quad (6.5)$$

From the equation (6.5) it can be seen that the torque requirement is much less than the motor torque, therefore we can use the selected servo motors.

6.3.2 Non–Electronic Components of the Construction

This section is devoted to the used non–electronic components to build the prototype.

As bobbin elements there were chosen finished aluminum extrusions. They are very convenient to use, since they are easily mounted in different forms of construction. The very bobbin is not too heavy, but enough by weight to ensure the structural reliability. Another advantage is the shape of the extrusions, which can be easily mounted on other parts and devices. The extrusions connection was carried out using angular brackets and t–bolts. The Figure 6.4 depicts the extrusions and fixturing elements.

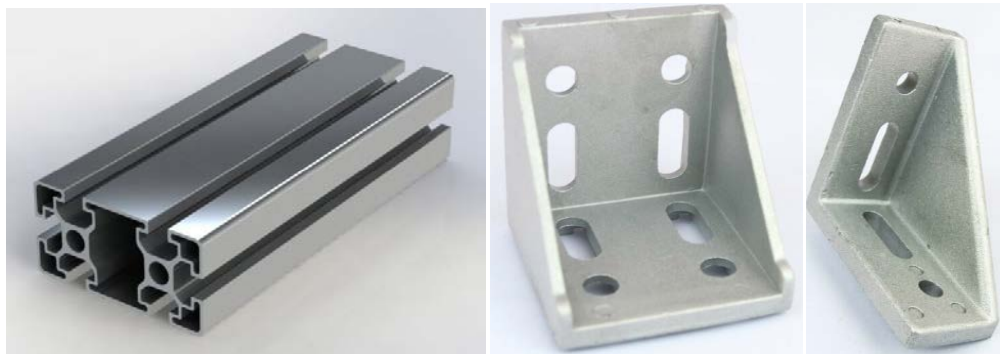

(a) Aluminum profile

(b) Angular brackets



(c) T-bolt

Figure 6.4. The components of the cable-driven robot body [51]

In capacity of the coils for cable there were taken the coils for fishing line and modified by making fixation holes in them. In the Figure 6.5 there is shown the coil for cables.

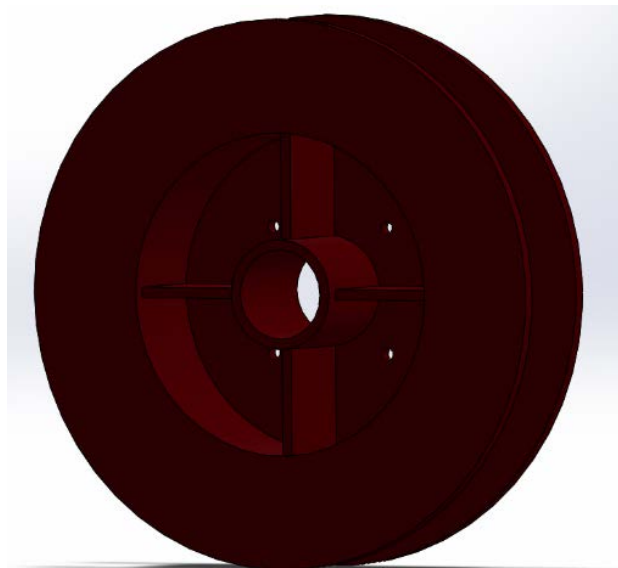

Figure 6.5. The coil for cables

The joining of the coil to the motor was carried out using the fixations coming fitted with the motor.

The fixing of the motors to the body was carried out through personally made fixations. The material was plastic. The Figure 6.6 depicts this fixation. It is fixed to the body (extrusion) with the help of the t-bolts.

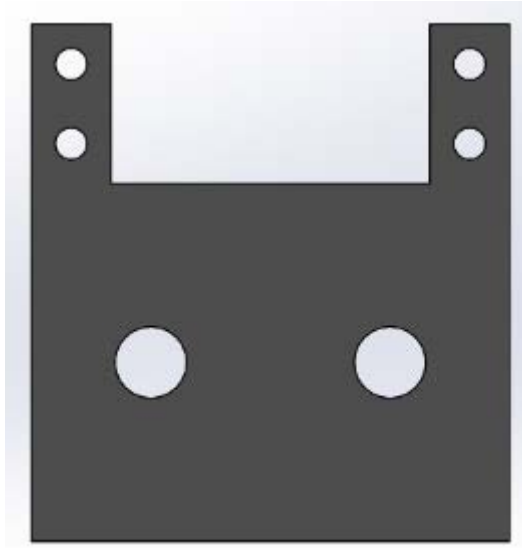

Figure 6.6. The fixation for the motor

The moving platform has also been made of plastic; it has a mass of approximately 300 grams and the dimensions of 150mm X 150mm X 6mm. The view of the platform is shown in the Figure 6.7.

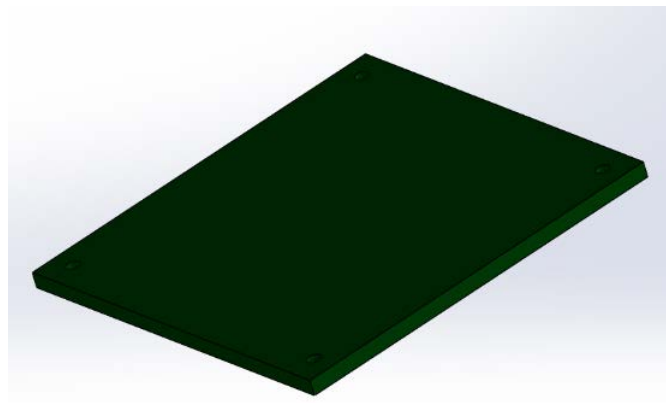

Figure 6.7. The moving platform

In capacity of the cables there was initially selected 1mm metal cable, but later, because of the assumptions made when moving (this will be discussed below), the metal cable was replaced on the string (thread) of the same thickness. Its advantages can be considered the best flexibility and low elasticity, so the thread is easily to spool and it doesn't reel out by itself. The strength properties of the used thread are more than enough for the experiments. The Figure 6.8 depicts the used cables.



(a) Steel cable

(b) String

Figure 6.8. The cables [52]

For connecting the moving platform and the cables, there were loops on each of them, and the screws were passed through them. After this, the screws were fixed to the platform using two nut screws.

6.3.3 Equipment for Future Use

Upon condition of the future possible use of the motors of another type there can be required the angle sensor (dual encoder). Dual encoder is a device that converts the rotation angle of the rotating object (the shaft) into an electrical signal, allowing determining this angle [53]. Need for such sensor is obvious, since the precise control of the rotation angle is important for more successful positioning of the moving platform. An example of the rotation sensor is presented in the Figure 6.9.



Figure 6.9. Angle Sensor [54]

Another important sensor is the cable tension sensor. It is necessary to check whether the existing tension of the cable corresponds to desired parameters. An example of such a sensor is shown in the Figure 6.10.



Figure 6.10. Cable tension sensor [55]

Another element, which is planned to use, is the CCTV camera. The example is shown in the Figure 6.11.



Figure 6.11. Observing camera [56]

The advantage of using such cameras is that they can transmit not only through the cable, but also the wireless communication, making them easy to use. They also have a large scope of view, high-quality video and, most importantly, low weight. The camera can transmit an image of good quality both at day and night. Given all these benefits, small surveillance cameras are an ideal candidate for use as a tool.

6.3.4 The Result of Prototyping

After selecting the electronic components and the collection of all the required elements, there was constructed a prototype of the cable-driven robot, which consists of a body, four motors with coils and a moving platform from which to each of the motors there

moves one cable. The Figure 6.12(a) depicts a three-dimensional model of the cable-driven robot and 6.12(b) depicts the real prototype.

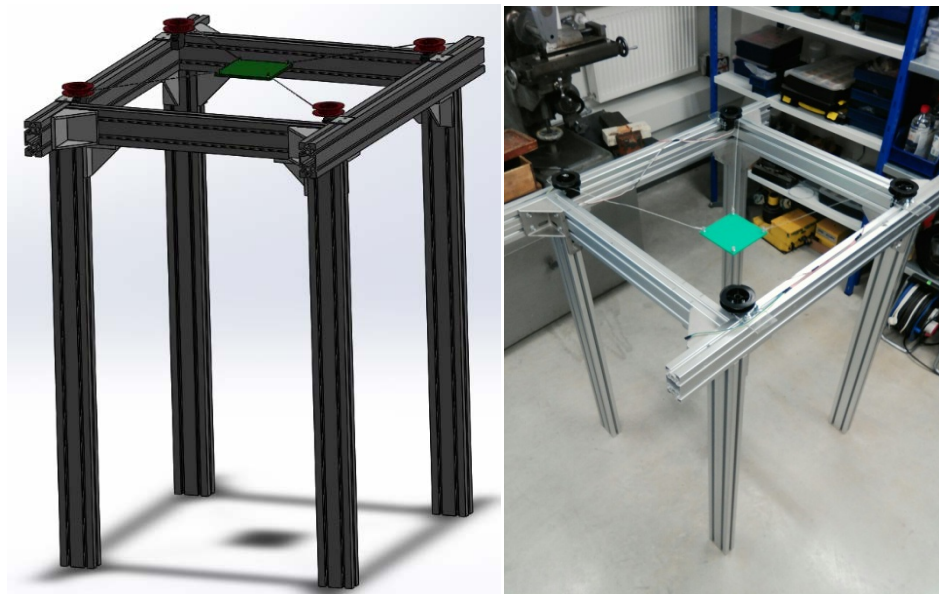

(a) Three-dimensional model of the robot (b) The prototype of the robot

Figure 6.9. The designed cable-driven robot

The Figure 6.13 depicts the workspace for the moving platform. The calculation is made on the assumption that the stationary coordinate system is located in the centre of the workspace. Then the limits on the x -axis for the edge of the platform are from -290mm to 290 mm and from -215mm to 215mm for the center of the platform, along the y -axis to the edge of the platform from -315mm to 315mm and from 240mm to 240mm for the center of the platform. These values can vary depending on the choice of the extrusions length and the desired workspace. The change takes place simply both structurally and from the point of view of the control system.

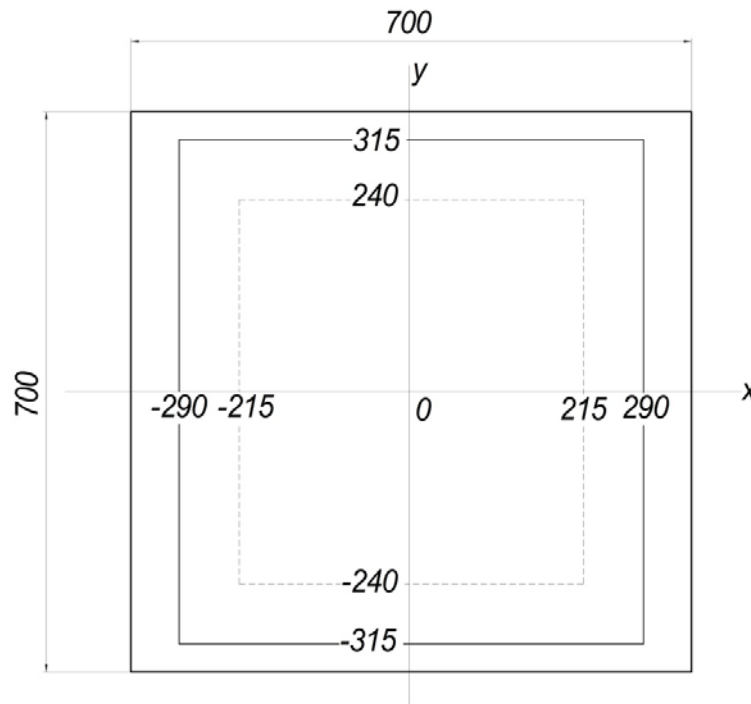

Figure 6.13. The workspace for the moving platform

The drawings of the manufactured parts are presented in the Appendix A.

6.4 Automation of Calculations and Control

For automation of calculations in the MATLAB program there was written the program that calculates the necessary rotation angles to achieve the specified coordinates, the achieved cables length and the speed that must be adhered at the motors. The text of the program is presented in the Appendix B.

As an example of the displacement work from the initial position to the position $x=0.2$ and $y=0.2$ we represent the following data:

The initial length of the cables: $l_{10}=0,3889$, $l_{20}=0,3889$, $l_{30}=0,3889$, $l_{40}=0,3889$

The finite length of the cables: $l_1=0,6718$, $l_2=0,4809$, $l_3=0,1061$, $l_4=0,4809$

The necessary rotation angles: $\theta_1=-11,3137$, $\theta_2=-3,6790$, $\theta_3=11,3137$, $\theta_4=-3,6790$.

This program is versatile and can be used for calculations for the cable-driven robots with other design parameters, making it useful for future research.

Using the programming environment of the cards with microcontrollers Arduino, there was written the program, with the help of which one can simulate the movement of the

platform. For writing there was used a special library to control the servo motors “Servo.h”. The text of the program is presented in the Appendix B. The Figure 6.14 depicts the control scheme, which was made for the layout of the cable–driven robot.

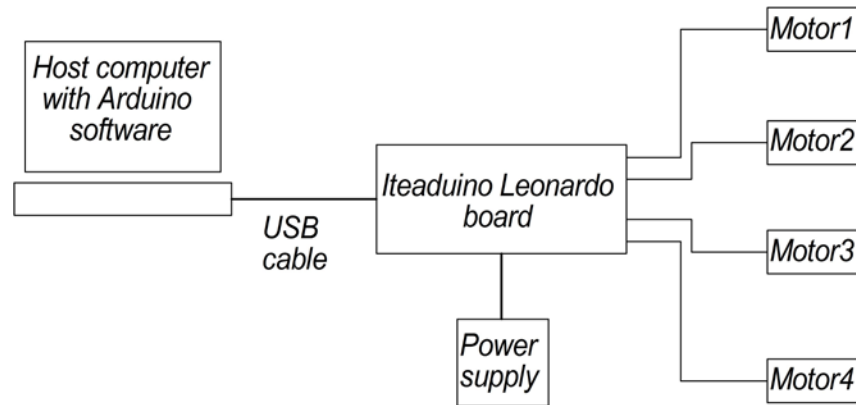

Figure 6.14. Control scheme of the cable–driven robot

The experiment and the results: After the complete structural assembly and writing the control program there was conducted the experiment to demonstrate the motions of the moving platform. It was conducted with certain assumptions: on the platform there were not installed the sensors that determine its position, the cables were not equipped with the sensors, tension strings, that is, there was a complete lack of feedback, but the purpose of the experiment in this work was to show only the motions of the platform that it can be implemented with this design. Instead of the metallic cable there was used the string. On the platform there was not installed the tool.

The obtained motions of the moving platform cannot be considered perfect, since there was no feedback and to control the accurate position of the platform was not possible. But as a demonstration of the motion principles, the principles of the cable–driven robot operating, the experiment can be considered successful, since during the performing of the experiment there were revealed some features of the motion; it became clear, on what points one should pay more attention. One such moment is to control tension of the cables. It is very important that the cables were always in tension, thus the condition of stiffness maintain between the platform and the frame, this means that received equations of kinematics and dynamics can be apply. To provide this tension, you need generate a torque on the motors and to periodically remove readings about tension of cables, that proves the need for feedback. I would also like to add that if other types of motors are using, it is necessary to establish sensors of angle rotation and improve the control system of angle control device. Such modernization will

provide more precise positioning of the moving platform. Again we see the need for feedback. It is also possible to make changes of some elements of construction, for example coils. They can be upgraded to provide better winding of the cable and prevent it slipping. From the foregoing, it is possible to define tasks for future work, the implementation of which will allow to do a full cable-driven robot.

Summary: In this chapter there was presented a set of materials to create the prototype of the cable-driven robot. There were described the software packages used for modeling, mathematical calculations and control systems, was submitted their application. Conclusions were drawn according to the results of the experiment.

7. CONCLUSION AND FUTURE WORK

Initial in-depth study of the subject helped to lay the foundation for awareness and understanding, what exactly are the cable-driven robots, what are their peculiarities of structure, in what fields they can be used, what one should pay attention to when designing. There were found the analogues, based on which there was conducted its own design of the cable-driven mechanism.

The next phase of mathematical analysis, which includes kinematic and dynamic analysis, and analysis of cable tension, allows not only to mathematically describe the projected cable-driven robot, but to make the derived by math basis for future developments of the cable-driven mechanisms, which was one of the goals of this research – to lay the foundations for other research.

The design phase of the layout of the cable-driven robot and its implementation can be considered successful, since in addition to three-dimensional computer model there was assembled a real prototype what can be used to demonstrate the principles of the moving platform motion. I would also like to note that the layout is quite simple to assemble, what makes it easy to disassemble and displace, or make a larger scale model, by replacing some parts.

An important outcome can be considered a statement of future objectives, what one should pay attention to ensure the assembly of the operating model of the cable-driven robot. Such objectives are:

- Providing feedback to control the cable tension and accurate positioning of the platform;
- Improvement of the control system, a combination of the settlement system and the command controller is possible;
- Selection and installation the tool on the platform and carrying out tests.

Based on the mentioned above facts, we can say that the work was done successfully; the main goal and subtasks were accomplished.

CONCLUSION IN ESTONIAN LANGUAGE

Esimene uuring andis teada mis kujutab ennast kaabelrobot. Oli ülevaadatud konstruktsiooni omapärad, kasutamise suunad ja projekteerimise põhipunktid. Olid leidnud analoogid, mille baasil oli määratud projekteerimine.

Järgmine etapp oli matemaatiline analüüs, mis sisaldab kinemaatikast, dünaamikast, trossi pinge analüüsist. Matemaatiline analüüs annab võimalust kirjeldada kaablirooboti ja annab baasi samasuguste seadmete projekteerimiseks.

Makeedi projekteerimine ja täitmine oli edukas. Oli tehtud nii arvutimudel kui ka reaalne mudel. Reaalne mudel võib olla kasutatud reaalseks liikumiseks demonstreerimiseks.

Tulevikuks tööks oli määratud ülesanded:

- Projekteerida tagasiside.
- Paraneda juhtimissüsteemi.
- Valida tööriste, paigutada platformile, kontrollida süsteemi.

Kokkuvõttes, töö on tehtud edukalt, kõik eesmärgid ja ülesanded on täidetud.

REFERENCES

- [1] Подураев, Ю.В. Основы мехатроники: Учебное пособие. Москва: МГТУ "СТАНКИН", 2000.
- [2] Фу, К., Гонсалес, Р., Ли, К. Робототехника: Пер. с англ. Москва: "Мир", 1989.
- [3] Попов, Е.П., Верещагин, А.Ф., Зенкевич, С.Л. Манипуляционные роботы: динамика и алгоритмы. Москва: "Наука", 1978.
- [4] Website of ABB Group <http://new.abb.com> (2.04.2016).
- [5] Website of ECHORD [WWW] <http://www.echord.info/wikis/website/home> (2.04.2016).
- [6] Vysin, M., Knoflicek, R. The hybrid mobile robot, IEEE International Conference on Industrial Technology, Maribor, Slovenia, vol. 1, pp. 263–264, 2003.
- [7] Website of GlobalSecurity.org [WWW] <http://www.globalsecurity.org/> (2.04.2016).
- [8] Website of Kinematics and Robot Design Group (IRI) [WWW] <http://www.iri.upc.edu/> (2.04.2016).
- [9] Merlet, J.P. Singularity Configurations of Parallel Manipulators and Grassmann Geometry, The International Journal of Robotics Research, vol. 8, pp. 45–56, 1989.
- [10] Website of Universidade Do Porto <http://paginas.fe.up.pt/> (2.04.2016).
- [11] Bonev, I.A., Zlatanov, D., Gosselin, C.M. Singularity analysis of 3–DOF planar parallel mechanisms via screw theory, Transactions of the ASME Journal of Mechanical Design, vol. 125, No. 3, pp. 573–81, 2003.
- [12] Collins, C.L., Long, G.L. The singularity analysis of an In–Parallel Hand Controller for Force–Reflected Teleoperation, IEEE Transaction on Robotics and Automation, vol. 11, No. 5, pp. 661–669, 1995.
- [13] Majou, F., Wenger, P., Chablat, D. Design of a 3 Axis Parallel Machine Tool for High Speed Machining: The Orthoglide, 4th International Conference on Integrated Design and Manufacturing in Mechanical Engineering (IDMME), Clermont–Ferrand, France, 2002.

- [14] Sugar, T.G., Fussell, P. Mouth–Operated Neurosurgical Robot, Proceeding of the ASME Design Engineering Technical Conference, Pittsburg, PA, USA, vol. 2, pp. 1113–1118, 2001.
- [15] Yang, G., Chen, W., Chen, I.M., Yeo, S.H., Chen, G. Design and Kinematic Analysis of Modular Reconfigurable Parallel Robots, Proceedings of the IEEE International Conference on Robotics and Automation, Detroit, MI, USA, vol. 4, pp. 2501–2506, 1999.
- [16] Tsai, L.W. Robot Analysis; The Mechanics of Serial and Parallel Manipulators, USA: John–Wiley and Sons, Inc.,1999.
- [17] Song, S.K., Know, D.S. Geometric Formulation Approach for Determining The Actual Solution of he Forward Kinematics of 6–DOF Parallel Manipulators, IEEE/RSJ International Conference on Intelligent Robots and Systems, Suwon, South Korea, vol. 2, pp. 1930–1935, 2002.
- [18] Wei, L., Griffis, M., Duffy, J. Forward Displacement Analyses of the 4–4 Stewart Platforms, ASME journal of mechanical design, vol. 114, No. 4, pp. 444–450, 1992.
- [19] Ku, D.M. Forward Kinematics Analysis of a 6–3 type Stewart Platform Mechanism, Proceedings of the Institution of Mechanical Engineers, Part K: Journal of Multi–body Dynamics, vol. 214, No. 4, pp. 233–241, 2000.
- [20] Williams II, R.L. Cable suspended haptic interface, International journal of virtual reality, vol. 3, No. 3, pp. 13–21, 1998.
- [21] Merlet, J.P. Parallel Robots, vol. 74, Netherlands: Kluwer Academic Publishers, 2000.
- [22] Gosselin, C., Angeles, J. Singularity Analysis of Closed–Loop Kinematic Chains, IEEE Transaction on Robotics and Automation, vol. 6, No. 3, pp. 281–290, 1990.
- [23] Chadwick, E.K.J., Nicol, A.C. Elbow and Wrist Joint Contact Forces During Occupational Pick and Place Activities, Journal of Biomechanics, vol. 33, No. 5, pp. 591–600, 2000.
- [24] Albus, J., Bostelman, R., Dagalakis, N. The NIST robocrane, Journal of Robotic System, vol. 10, No. 5, pp. 709–724, 1993.

[25] Bostelman, R., Albus, J., Dagalakis, N., Jacoff, A., Gross, J. Application of the NIST ROBOCRANE, Proceedings of the 5th International Symposium on Robotics and Manufacturing, Maui, HI, vol. 5, pp. 403–407, 1994.

[26] Website of National Institute of Standards and Technology (NIST) [WWW] <http://www.nist.gov/> (6.04.2016).

[27] Ming, A., Higuchi, T. Study of Multiple Degree-Of-Freedom Positioning Mech Using Wires (Part 1) – Concept, Design and Control, International Journal of Japan Society Precision Engineering, vol. 28, No. 2, pp. 131–138, 1994.

[28] Ming, A., Higuchi, T. Study of Multiple Degree-Of-Freedom Positioning Mech Using Wires (Part 2) – Development Of Planar Completely Restrained Positioned Mechanism, International Journal of Japan Society Precision Engineering, vol. 28, No. 2, pp. 235–242, 1994.

[29] Pham, C.B. Analysis and design of cable-driven parallel kinematic mechanism, PhD dissertation, Nanyang Technological University, Singapore, 2005.

[30] Bosscher, P., Ebert-Uphoff, I. A stability measure for underconstrained cable-driven robots, In Proceedings of IEEE Conference on Robotics and Automation, New Orleans, LA, USA, vol. 5, pp. 4943–4949, 2004.

[31] Slagowski, S., Potter, A. Using ADAMS to Model Cable-Driven Hyper-Redundant Flexible Manipulators, presented at International ADAMS User Conference, 2000.

[32] Homma, K., Fukuda, O., Yoshihiko, Y. Study of a wire-driven leg rehabilitation system, Proceedings of the IEEE International Conference on Intelligent Robots and Systems, Lausanne, Switzerland, vol. 2, pp. 1451–1456, 2002.

[33] Kawamura, S., Ida, M., Wada, T., Wu, J.L. Development of Virtual Sports Machine Using a Wire Drive System – A Trial of Virtual Tennis, Proceeding of IEEE/RSJ International Conference on Intelligent Robots and Systems, Washington, DC, USA, vol. 1, pp. 111–116, 1995.

[34] Dougherty, E.J., Lee, D.E., Shively, P.D. Automated All-weather Cargo Transfer System (AACTS), Society of Naval Architects and Marine Engineers, STAR Symposium, pp. S2-3-1, S2-3-6, 1989.

[35] Gorman, J.J., Jablokow, K.W., Cannon, D.J. The cable array robot: Theory and experiment, in Proceeding of the IEEE International Conference on Robotics and Automation, Seoul, Korea, vol. 3, pp. 2804–2810, 2001.

[36] Website of SKYCAM <http://skycam.tv.s28625.gridserver.com/> (10.02.2016).

[37] Tavolieri, C. Design of a Cable–Based Parallel Manipulator for Rehabilitation Applications, PhD dissertation, University of Cassino, Italy, 2008.

[38] Голованов, Н.Н. Геометрическое моделирование, Москва: Издательство Физико–математической литературы, 2002.

[39] Oh, S.R., Agrawal, S.K. Cable–Suspended Planar Parallel Robots with Redundant Cables: Controllers with Positive Cable Tension, Proceedings of the IEEE International Conference on Robotics and Automation, Taipei, Taiwan, vol. 3, pp. 3023–3028, 2003.

[40] Banadaki, S.M.D. Modeling and Control of Cable–Driven Robots, Master Thesis, Nanyang Technological University, Singapore, 2007.

[41] Craig, J.J. Introduction to Robotics – Mechanics and Control, Addison–Wesley Publishing Company, 1986.

[42] Nanua, Y., Waldron, K.J., Murphy, V. Direct kinematic solution of a Stewart platform, in IEEE Transaction on Robotics and Automation, vol. 6, No. 4, pp. 438–444, 1990.

[43] Shen, Y., Osumi, H., Arai, T. Manipulability measures for multi–wire driven parallel mechanism, in Proceedings of the IEEE International Conference on Industrial Technology, Guangzhou, China, vol. 1, pp. 550–554, 1994.

[44] Vadia, J. Planar Cable Direct Driven Robot: Hardware Implementation, Master Thesis, Russ College of Engineering and Technology of Ohio University, USA, 2003.

[45] Website of 2D–3D [WWW] <http://www.2d-3d.ru/> (10.05/2016).

[46] Website of MathWorks <http://matlab.ru/> (10.05/2016).

[47] Website of Arduino [WWW] <https://www.arduino.cc/> (10.05/2016).

[48] Website of CRCibernetica [WWW] <http://www.crcibernetica.com/> (10.05/2016).

[49] Website of YEInternational <http://yeint.ee/> (10.05/2016).

- [50] Website of ITT GROUP [WWW] <http://www.ittgroup.ee/et/> (2.05.2016).
- [51] Website of Крепёжные системы <http://profil-t.ru/> (4.05.2016).
- [52] Website of K-Rauta [WWW] <https://www.k-rauta.ru/> (6.05.2016).
- [53] Website of Wikipedia <https://en.wikipedia.org/> (4.05.2016).
- [54] Website of RoboCraft <http://robocraft.ru/> (4.05.2016).
- [55] Website of Magtrol [WWW] <http://www.magtrol.ru/> (7.05.2016).
- [56] Website of Наблюдаю.py <http://nabludau.ru/> (7.05.2016).

APPENDICES

Appendix A: Drawings

List of drawings:

1. Frame
2. Mount for motor
3. Coil
4. Platform

Appendix B: Program Codes

MATLAB program code:

```
% clear; clc;
r=0.025;% Coil radius
Z=[0.2 0.2 0];% Input parameters x, y and angle fi
% Calculation parameters of movement on intervals
for i=1:3000
    zz(:,i)=i*Z/(18*1000);
    z(:,i)=zz(:,i)*i/2000;
end

for i=3001:6000
    zz(:,i)=Z/6;
    z(:,i)=z(:,3000)+zz(:,i)*(i-3000)/1000;
end

for i=6001:9000
    zz(:,i)=Z/6-(i-6000)*Z/(18*1000);
    z(:,i)=Z/4+z(:,6000)-zz(:,i)*(i-6000)/2000;
end

for g=1:9000
    x=z(1,g);
    y=z(2,g);
    fi=z(3,g);

qx=[-0.075 -0.075 0.075 0.075];% qx=(qx1 qx2 qx3 qx4)
qy=[-0.075 0.075 0.075 -0.075];% qy=(qy1 qy2 qy3 qy4)

dx=[-0.35 -0.35 0.35 0.35];% dx=(dx1 dx2 dx3 dx4)
dy=[-0.35 0.35 0.35 -0.35];% dy=(dy1 dy2 dy3 dy4)

% Initial parameters
x0=0;
y0=0;
fi0=0;

for i=1:4
    l0(i)=sqrt((x0+qx(i)*cos(fi0)-qy(i)*sin(fi0)-dx(i))^2+(y0+qx(i)*sin(fi0)+qy(i)*cos(fi0)-dy(i))^2);% Initial length each of cables
    l(i)=sqrt((x+qx(i)*cos(fi)-qy(i)*sin(fi)-dx(i))^2+(y+qx(i)*sin(fi)+qy(i)*cos(fi)-dy(i))^2);% Length of the cable in the specified position
    lx(i)=(x+qx(i)*cos(fi)-qy(i)*sin(fi)-dx(i));% Projection of the length of cable on x
    ly(i)=(y+qx(i)*sin(fi)+qy(i)*cos(fi)-dy(i));% Projection of the length of cable on y
    Q(i)=(l0(i)-l(i))/r;% Required angle of rotation
    qq(i,:)=[-lx(i)/(r*l(i)) -ly(i)/(r*l(i)) -((-qx(i)*sin(fi)-qy(i)*cos(fi))+(qx(i)*cos(fi)-qy(i)*sin(fi))*ly(i))/(r*l(i))];% Rotation speed
end
% Acceleration calculation
```



```
QQ(:,g)=qq*zz(:,g);  
end
```

```
for i=1:4  
    x0=x;  
    y0=y;  
    fi0=fi;  
end
```

Arduino program code:

```
#include <Servo.h> // Open the library for controlling servo motors  
// Assign names to each of motors  
Servo servo1;  
Servo servo2;  
Servo servo3;  
Servo servo4;  
int Q1,t,v1,v11,Q2,v2,v22,Q3,v3,v33,Q4,v4,v44; // Denote variables  
void setup()  
{  
    // Assign to each of motors input/output on the board  
    servo1.attach(0);  
    servo2.attach(2);  
    servo3.attach(4);  
    servo4.attach(6);  
}  
void loop()  
{  
    Q1=500;Q2=500;Q3=-500;Q4=-500; // Задаём углы  
    t=5; // Time of moving  
    // Velocity calculation and choice of direction of rotation  
    v1=Q1/t;v2=Q2/t;v3=Q3/t;v4=Q4/t;  
    if (Q1<0) v11=100-v1;  
    else if (Q1>0) v11=93-v1;  
    else if (Q1==0) v11=97;  
    if (Q2<0) v22=93+v2;  
    else if (Q2>0) v22=102+v2;  
    else if (Q2==0) v22=98;
```

```
if (Q3<0) v33=99-v3;
else if (Q3>0) v33=91-v3;
else if (Q3==0) v33=96;
if (Q4<0) v44=93+v4;
else if (Q4>0) v44=101+v4;
else if (Q4==0) v44=98;
// Run motors for a time 5 seconds
servo1.write(v11);
servo2.write(v22);
servo3.write(v33);
servo4.write(v44);
delay(5000);
// Stop the motors
servo1.write(98);
servo2.write(98);
servo3.write(96);
servo4.write(98);
delay(1000000);
}
```

4

3

2

1

F

F

E

E

D

D

C

C

B

B

A

A

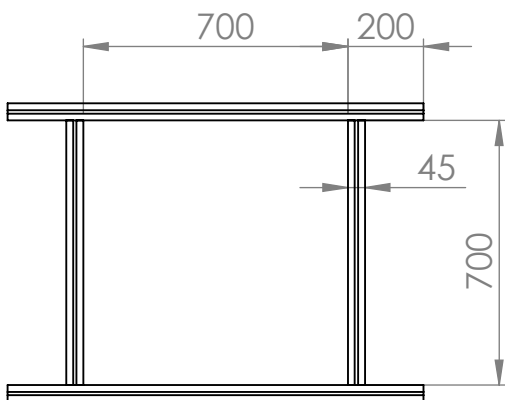
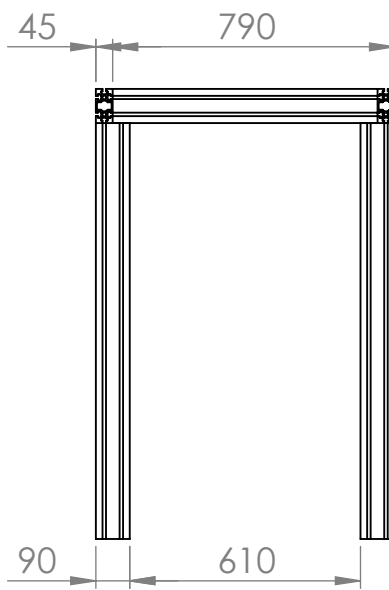
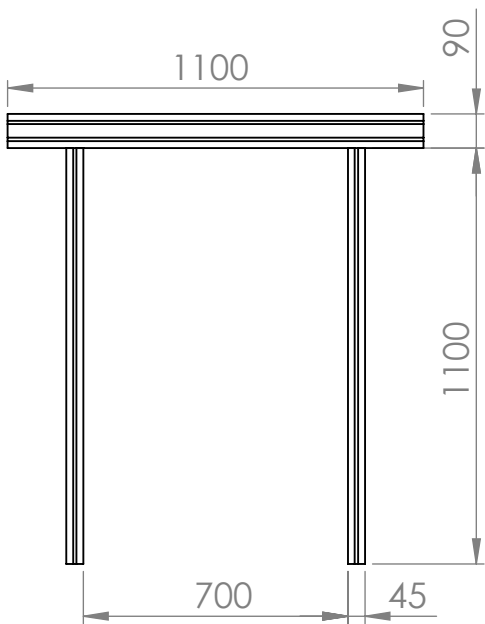

UNLESS OTHERWISE SPECIFIED:
 DIMENSIONS ARE IN MILLIMETERS
 SURFACE FINISH:
 TOLERANCES:
 LINEAR:
 ANGULAR:

FINISH:

DEBURR AND
 BREAK SHARP
 EDGES

DO NOT SCALE DRAWING

REVISION

TALLINN UNIVERSITY OF TECHNOLOGY

| | NAME | SIGNATURE | DATE |
|--------|-----------|-----------|------|
| DRAWN | DANIIL M. | | |
| CHK'D | ROBERT H. | | |
| APPV'D | | | |
| MFG | | | |
| Q.A | | | |

TITLE:

Frame

MATERIAL:

Aluminium

DWG NO.

1

A4

WEIGHT:

SCALE:1:20

SHEET 1 OF 1

4

3

2

1

4

3

2

1

F

F

E

E

D

D

C

C

B

B

A

A

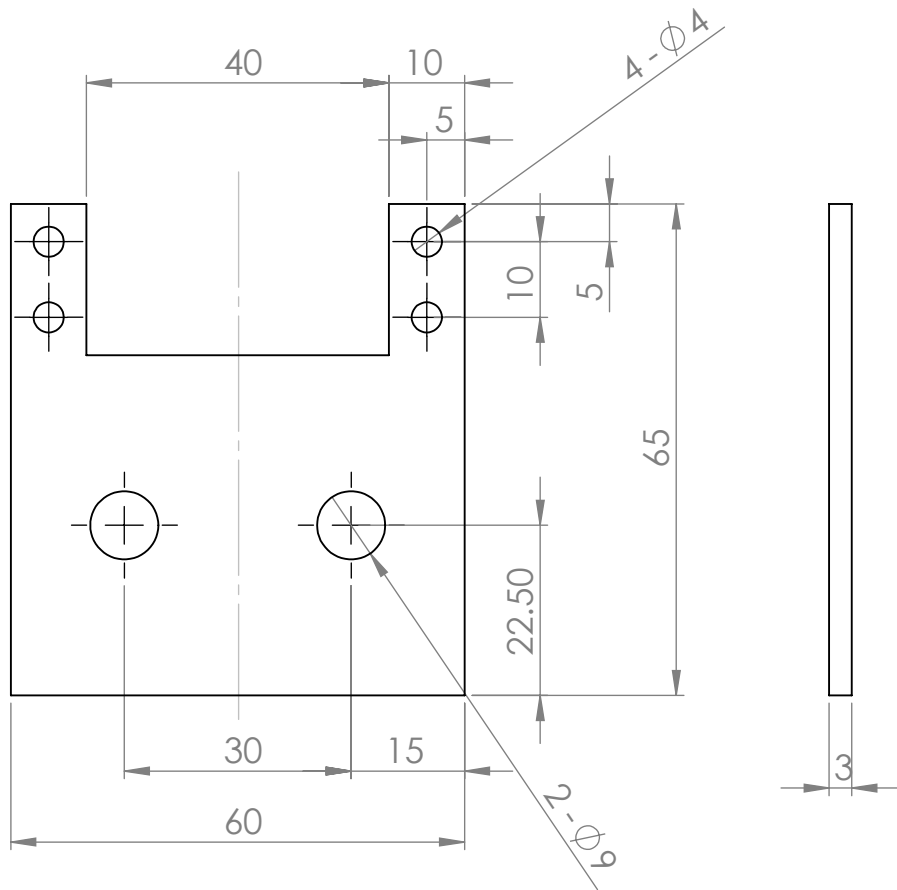

UNLESS OTHERWISE SPECIFIED:
 DIMENSIONS ARE IN MILLIMETERS
 SURFACE FINISH:
 TOLERANCES:
 LINEAR:
 ANGULAR:

FINISH:

DEBURR AND
 BREAK SHARP
 EDGES

DO NOT SCALE DRAWING

REVISION

TALLINN UNIVERSITY OF TECHNOLOGY

| | NAME | SIGNATURE | DATE |
|--------|-----------|-----------|------|
| DRAWN | DANIIL M. | | |
| CHK'D | ROBERT H. | | |
| APPV'D | | | |
| MFG | | | |
| Q.A | | | |
| | | | |
| | | | |
| | | | |
| | | | |

TITLE:

Mount for motor

MATERIAL:

Plastic

DWG NO.

2

A4

WEIGHT:

SCALE:1:1

SHEET 1 OF 1

4

3

2

1

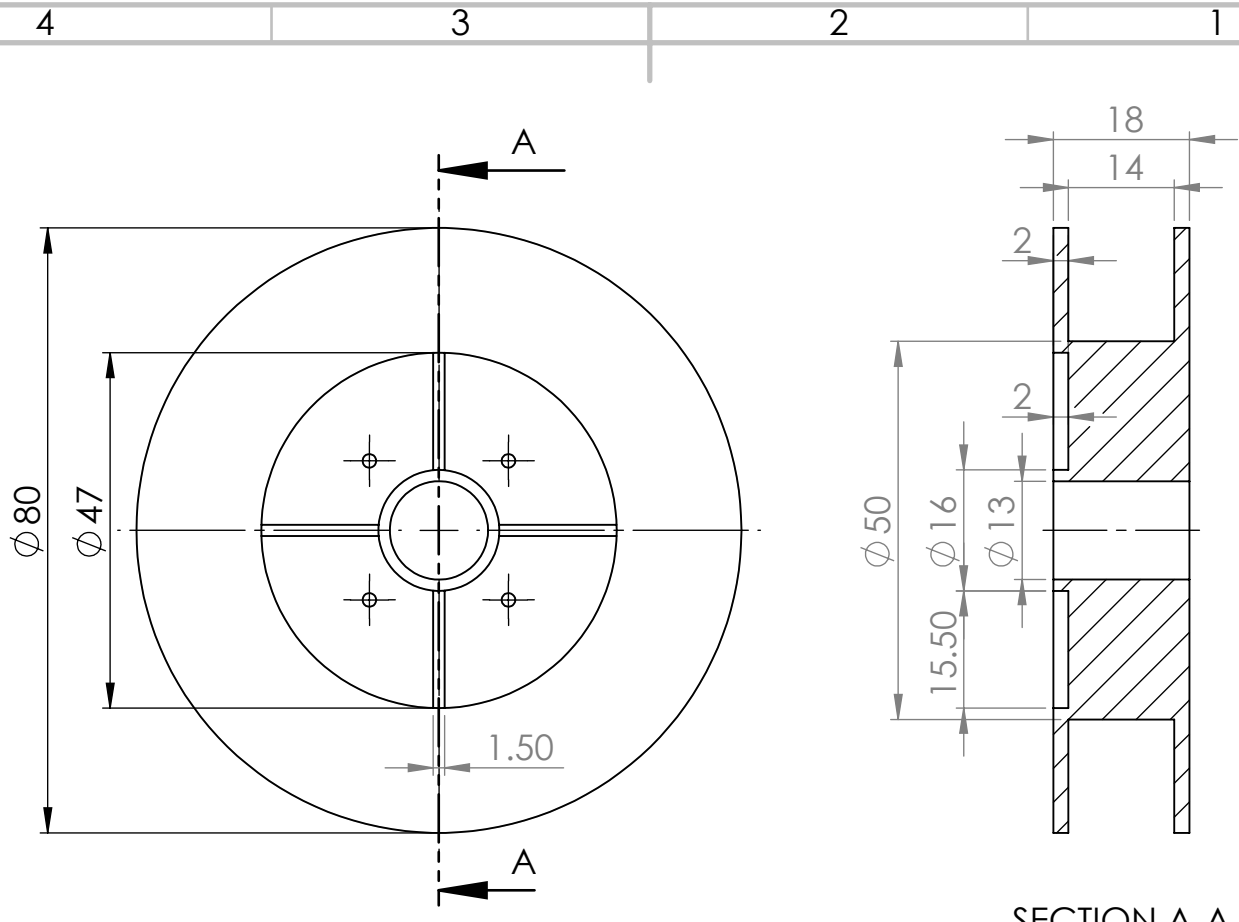

SECTION A-A

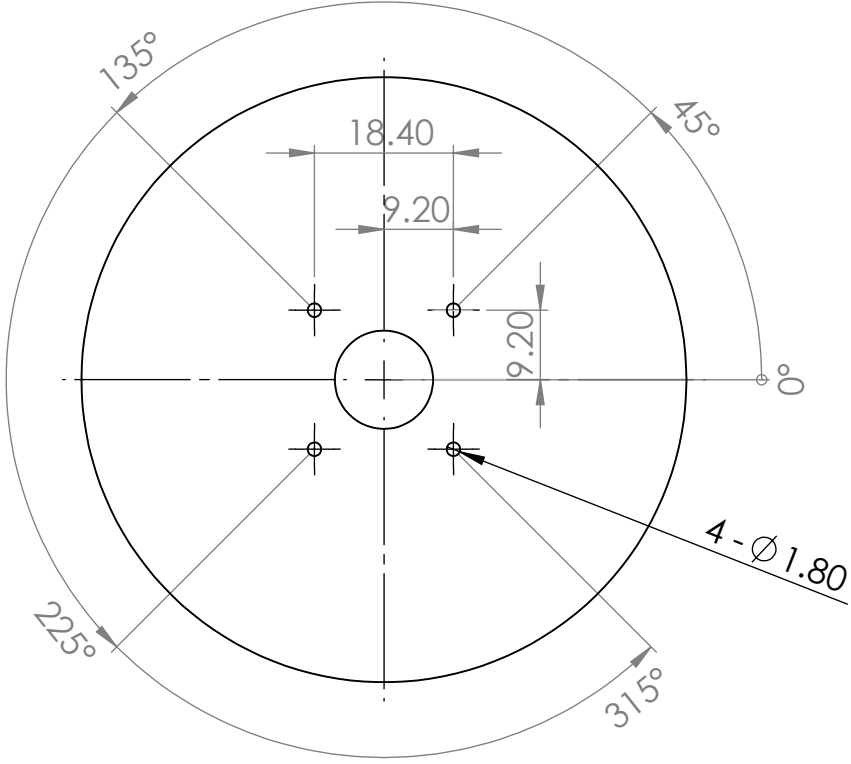

| | | | | | | |
|---|-----------------------------|------|-----------------------|------------------------------------|----------------------------------|----------|
| UNLESS OTHERWISE SPECIFIED: DIMENSIONS ARE IN MILLIMETERS SURFACE FINISH: TOLERANCES: LINEAR: ANGULAR: | | | FINISH: | DEBURR AND BREAK SHARP EDGES | DO NOT SCALE DRAWING | REVISION |
| | | | | | TALLINN UNIVERSITY OF TECHNOLOGY | |
| NAME | SIGNATURE | DATE | TITLE: Coil | | | |
| DRAWN DANIIL M. | | | | | | |
| CHK'D ROBERT H. | | | | | | |
| APPV'D | | | | | | |
| MFG | | | | | | |
| Q.A | MATERIAL: Plastic | | | DWG NO. 3 | | A4 |
| WEIGHT: | | | SCALE:1:1 | | SHEET 1 OF 1 | |

4

3

2

1

F

F

E

E

D

D

C

C

B

B

A

A

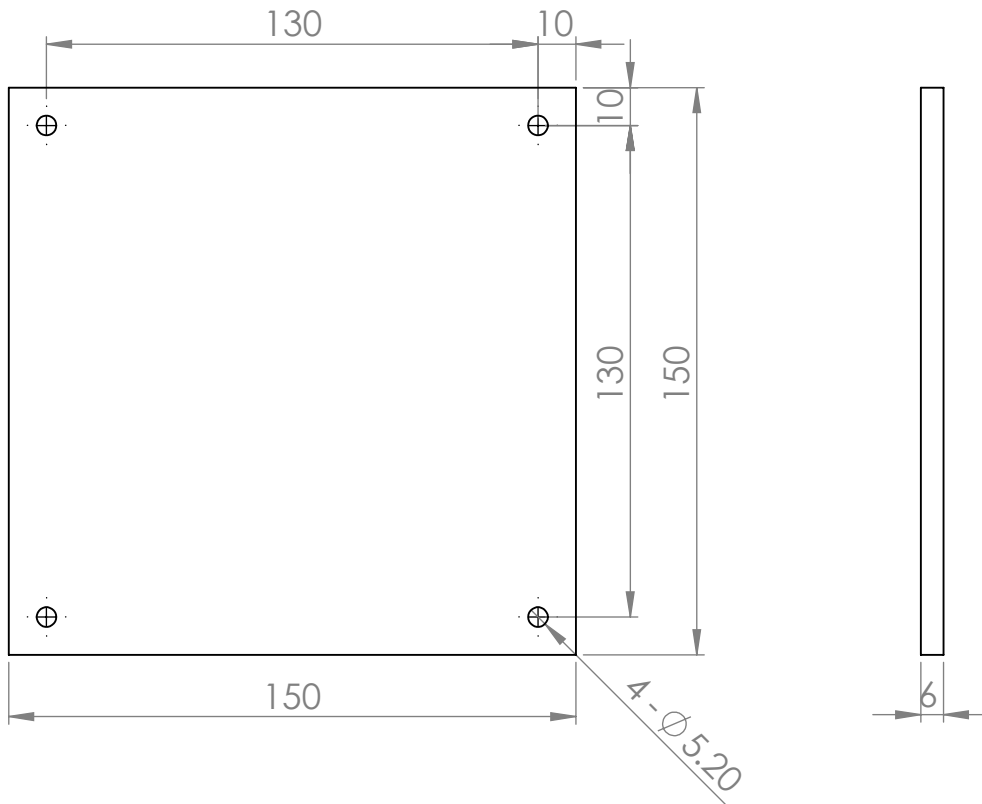

UNLESS OTHERWISE SPECIFIED:
 DIMENSIONS ARE IN MILLIMETERS
 SURFACE FINISH:
 TOLERANCES:
 LINEAR:
 ANGULAR:

FINISH:

DEBURR AND
 BREAK SHARP
 EDGES

DO NOT SCALE DRAWING

REVISION

TALLINN UNIVERSITY OF TECHNOLOGY

| | NAME | SIGNATURE | DATE | | |
|--------|-----------|-----------|------|--|--|
| DRAWN | DANIIL M. | | | | |
| CHK'D | ROBERT H. | | | | |
| APPV'D | | | | | |
| MFG | | | | | |
| Q.A | | | | | |
| | | | | | |
| | | | | | |
| | | | | | |
| | | | | | |
| | | | | | |
| | | | | | |

TITLE:

Platform

MATERIAL:

Plastic

DWG NO.

4

A4

WEIGHT:

SCALE:1:2

SHEET 1 OF 1

4

3

2

1