



TALLINN UNIVERSITY OF TECHNOLOGY

SCHOOL OF ENGINEERING

Department of Mechanical and Industrial Engineering

Analysis of Customer Specific Signal Cable Assembly Development for an International ICT Company Providing Hardware Solutions for Cellular Networks

Kliendi spetsiifiliste signaalkaablite arendamise analüüs mobiilsidevõrgu riistvara lahendusi pakkuvale rahvusvahelisele info- ja kommunikatsioonitehnoloogia ettevõttele

MASTER'S THESIS

Student: Oliver Parv
Student code: 178162MARM
Supervisor: Kristo Karjust, PhD

Tallinn 2020

AUTHOR'S DECLARATION

Hereby I declare, that I have written this thesis independently.
No academic degree has been applied for based on this material. All works, major viewpoints and data of the other authors used in this thesis have been referenced.

"....." 202....

Author:
/signature /

Thesis is in accordance with terms and requirements

"....." 202....

Supervisor:
/signature/

Accepted for defence

"....."..... 202....

1) Chairman of theses defence commission:
/name and signature/

Non-exclusive Licence for Publication and Reproduction of Graduation thesis¹

I, Oliver Parv (09/04/1992) hereby

1. grant Tallinn University of Technology (TalTech) a non-exclusive license for my thesis

Analysis of customer Specific Signal Cable Assembly Development for an International ICT Company Providing Hardware Solutions for Cellular Networks,

supervised by Kristo Karjust,

1.1 reproduced for the purposes of preservation and electronic publication, incl. to be entered in the digital collection of TalTech library until expiry of the term of copyright;

1.2 published via the web of TalTech, incl. to be entered in the digital collection of TalTech library until expiry of the term of copyright.

1.3 I am aware that the author also retains the rights specified in clause 1 of this license.

2. I confirm that granting the non-exclusive license does not infringe third persons' intellectual property rights, the rights arising from the Personal Data Protection Act or rights arising from other legislation.

¹ Non-exclusive Licence for Publication and Reproduction of Graduation Thesis is not valid during the validity period of restriction on access, except the university`s right to reproduce the thesis only for preservation purposes.

_____ (signature)

_____ (date)

Department of Mechanical and Industrial Engineering

THESIS TASK

Student: Oliver Parv, 178162MARM

Study programme, MARM06/15, Industrial Engineering and Management

Supervisor: Professor, Kristo Karjust, +372 620 3260

Thesis topic:

(in English) Analysis of Customer Specific Signal Cable Assembly Development for an International ICT Company Providing Hardware Solutions for Cellular Networks

(in Estonian) Kliendi spetsiifilise signaalikaabli arendamise analüüs mobiilsidevõrgu riistvara lahendusi pakkuvale rahvusvahelisele info- ja kommunikatsioonitehnoloogia ettevõttele

Thesis main objectives:

- 1.Product development process improvements of cable manufacturing company
- 2.Development of profit expectations model for new products

Thesis tasks and time schedule:

No	Task description	Deadline
1.	Collecting data about the company, the customer, market	25/05/2020
2.	Analysis of current product development process within the cable manufacturing company	25/05/2020
3.	Conducting financial analysis of the project based on model	25/05/2020

Language: EN Deadline for submission of thesis: "25" May 2020

Student: "....." 2020
/signature/

Supervisor: "....." 2020
/signature/

Head of study programme: "....." 2020
/signature/

TABLE OF CONTENTS

INTRODUCTION	7
1 BACKGROUND	8
1.1 Mobile Access Network.....	8
1.2 International ICT company	10
1.2.1 Operations, products and services	10
1.2.2 ICT Market overview	12
1.3 Cable manufacturing company	15
1.3.1 Operations, products and services	15
1.3.2 Cable assembly market overview	16
1.4 New product development theory	17
1.5 Conclusions	20
2 METHODOLOGY	21
2.1 Research strategy description	21
2.2 Overview of data sources and questionnaire analysis	22
2.2.1 Development process overview of new cable assemblies	25
2.2.2 Overview of developing new RJ45-RJ45 signal cables to the ICT company ...	29
2.3 Economic calculations	32
Analysis period.....	32
Profit and loss statement	32
Project profitability model and financial metrics	33
Sensitivity analysis	35
2.4 Conclusions	35
3 SYNTHESIS AND ANALYSIS	36
3.1 Product development process analysis	36
3.2 Project profitability calculations	36
3.3 Sensitivity analysis	39
3.4 Conclusions and suggestions.....	40
SUMMARY	41
LIST OF REFERENCES	42
APPENDICES	48

ABSTRACT

The topic of this master's thesis is "Analysis of Customer Specific Signal Cable Assembly Development for an International ICT Company Providing Hardware Solutions for Cellular Networks".

The writing was prompted by the challenges of developing new cable assemblies to an ICT company. As an example, a case study describing new product development of two RJ45-RJ45 signal cables was used. The main objective of the thesis was the analysis of current product development process within an anonymous cable manufacturing company. In order to meet customer expectations, identification of problematic areas in that process and generate ideas of improvement.

To achieve the objective, the author first investigated the role of cable assemblies within mobile networks, provided an overview of the two companies under study, their markets and presented the theoretical approach for new product development. This was followed by the description of new product development processes within the cable manufacturing company, the description and analysis of the case study. Additionally, a profit expectations model was constructed followed by profitability calculations and sensitivity analysis based on the case study for further input.

The author came to the conclusion that while the cable manufacturing company has wide-spread standardized processes in place, it needs to optimize its fixed costs to be more price competitive and assess its current supplier base alongside with manufacturing footprint to increase agility.

Key words: cellular network, cell site, ICT, new product development, cable assembly, cable manufacturing, profitability, master's thesis

INTRODUCTION

The main challenge of cable assembly development process is that the product must meet the technical requirements and deadlines with the addition of customer expectations on pricing and lead times. At the same time, the product must be profitable for the company that manufactures the cable assemblies. This is a hurdle that the cable manufacturers face and must overcome in their daily operations in order to be competitive and financially sustainable. In case the development process takes too long or the offered product does not meet the requirements and has uncompetitive pricing, then the business opportunity will be lost.

In this master's thesis, the author is describing and analysing a case study where, on the request of an ICT company, an anonymous cable manufacturing company developed two RJ45-RJ45 signal cable assemblies. The main objective of the dissertation is the analysis of the current product development process within the cable company, identification of the problematic areas within that process and propositions of improvement in order to meet customer requirements and expectations.

The entire volume of the master's thesis together with the title page is 60 pages. The work consists of an abstract, an introduction, three body chapters, a summary, a list of cited sources and three appendices. In the first chapter, the function of cable assemblies within mobile networks is explained, followed by an overview of the two studied companies and the markets they compete in. The chapter is finished by describing the theoretical approach towards new product development.

The second chapter contains a description of the research strategy, provides an overview of the data sources, new product development processes within the cable manufacturing company. The chapter also contains the description of the case study followed development theory of the profit expectations model and the methodology of calculations performed in the course of the work. The third chapter contains the analysis of the product development process and calculation results and improvement proposals.

The content of this master's thesis could be practical for the signal cable manufacturing company it's based on and also to other manufacturers who are also continuously developing new cable assemblies to customers with similar background facing the same challenges.

1 BACKGROUND

1.1 Mobile Access Network

Mobile access network is a wireless communication system where mobile users, also known as terminals move around in the service area and will from time to time require communication services in the form of a wireless connection or packet transmission to and from a fixed (aka core) network (Miao *et al.*, 2016). The primary of the goal of the wireless network is to provide the services of a fixed network such as voice calls or internet access to a large number of mobile or stationary users spread over a geographical area (*Ibid.*).

To provide the services of the network, for instance to connect mobile users to fixed or other mobile users in the network or servers, the wireless network (cellular network) is stretched out by hundreds or thousands of radio base stations, located in cell sites, each supporting several radio channels. The advantages of using several hundreds or thousands of cell sites is an increase of the number of radio connections available to users in comparison to using a single cell site with the same geographical coverage, also known as (radio) cell (Hoy, 2016).

The network uses several frequencies and the rule of thumb is that the higher the frequency of the radio signal transmitted from the cell site, the smaller the cell as seen in Figure 1.1. (*Ibid.*).

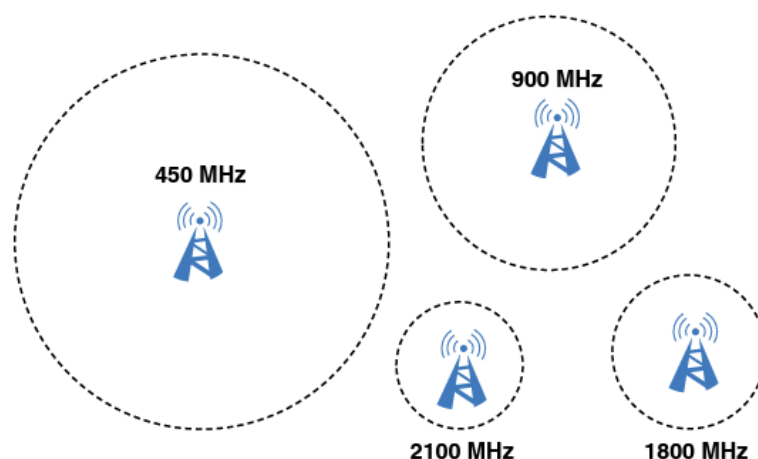

Figure 1.1 Cell size and frequency (Hoy, 2016).

Most radio base stations support frequency-division duplex (FDD) air interface service, in which each cell supplies separate uplink (transmit path from mobile to base station) and downlink (receive path from base station to mobile) radio channels operating on a certain radio frequency to serve network users. To simplify network radio planning, uplink and downlink channels are usually implemented as a pair of radio channels, meaning whichever uplink channel a phone is allocated in a cell, it will always use the specific corresponding downlink channel (visualised in Figure 1.2) (*Ibid.*). At the same time, the core network makes connections between different base stations possible which in turn provide the wireless connections to the mobiles (Miao *et al.*, 2016)

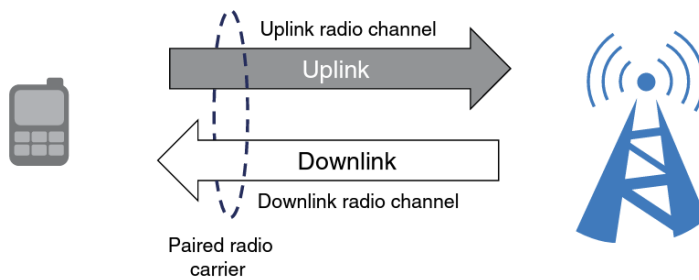

Figure 1.2 Channels and carriers (Hoy, 2016)

Cellular networks are usually divided into three areas (Hoy, 2016):

- 1) mobile devices – mobile phones, tablets and other devices that use cellular services;
- 2) radio access network (RAN) – cells, radio base stations and other radio and access control elements;
- 3) core network or fixed network (Miao *et al.*, 2016) – network's central administrative and interconnection services.

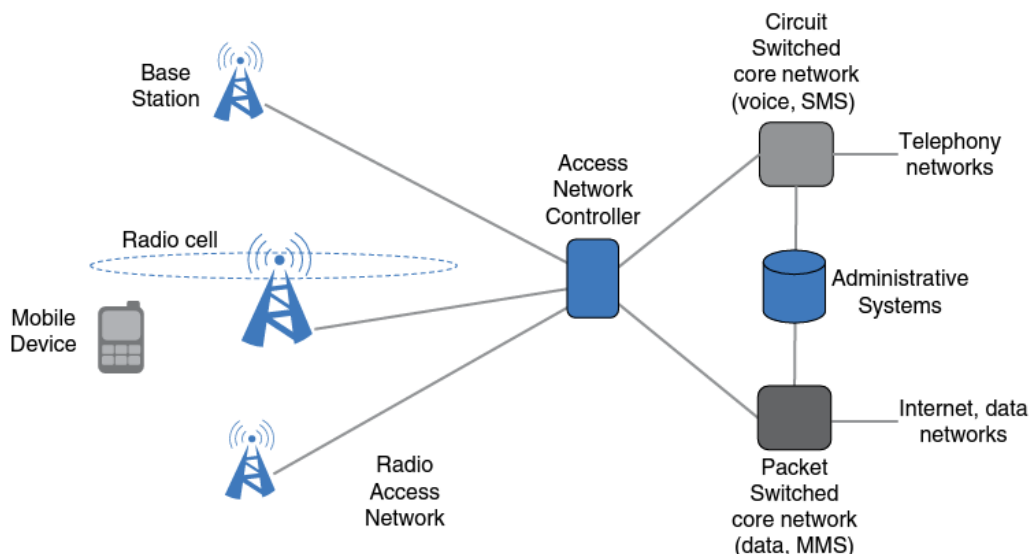

Figure 1.3 General cellular network architecture (Hoy, 2016)

Due to the nature of the case study, the rest of the subchapter will be focusing on the radio access network as the cables described under Chapter 2 are used there.

A radio base station located in the cell site is from where radio frequencies (cells) are transmitted. The hardware elements deployed at a cell site include at least one baseband unit (BBU), remote radio unit (RRU) and antenna (transmitter) (Al-Falahy, Alani, 2017). Also included in the radio station is the infrastructure required to support the site such as power and transmission equipment such as a rectifier (Ericsson, 2016) and potentially also a tower (Littlefuse). As illustrated under Figure 1.4, hardware used in a radio base station is connected to each other with different cable assemblies. For example, with RF cable assemblies between the RRUs and the antenna units, fiber cable assemblies between RRUs and BBUs (Al-Falahy, Alani, 2017) and power cable assemblies between RRUs and rectifiers.

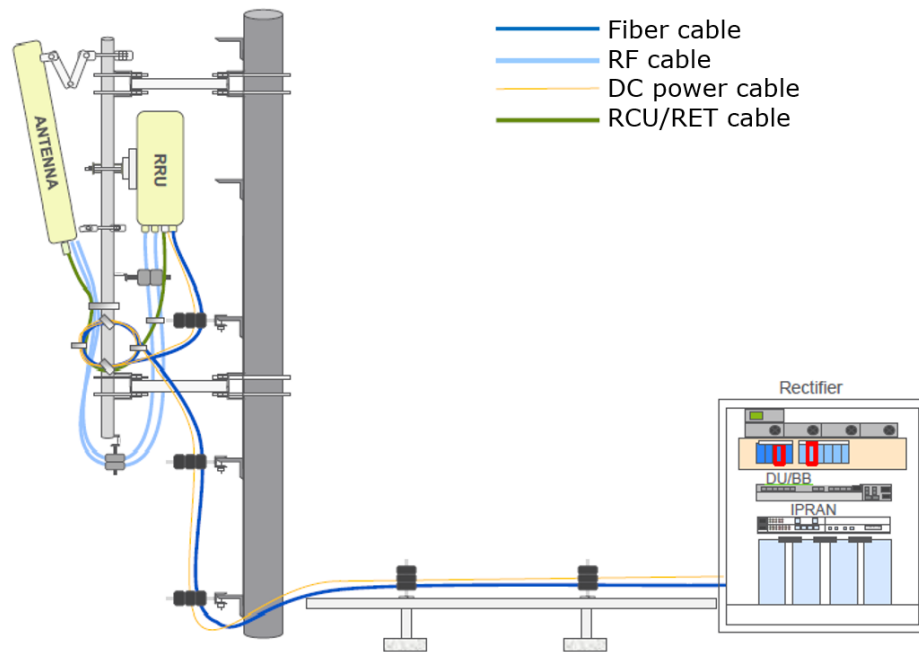

Figure 1.4 Example of a single sector (cell) site (Ericsson, 2016)

1.2 ICT company

1.2.1 Operations, products and services

The described company is one of the world leading providers of information and communication technology to the service providers operating in the same area. The company is specialized on developing, delivering and managing mobile telecommunications, also known as cellular networks including different hardware,

software and services, with the main customers being the operators of mobile voice and multimedia services through mobile telecommunications networks such as AT&T, Verizon, China Mobile, T-Mobile (Telecommunication ..., 2018). The company is an employer for 100 thousand people worldwide and the annual revenue of the company is over 20 billion USD. The company is structured as follows:

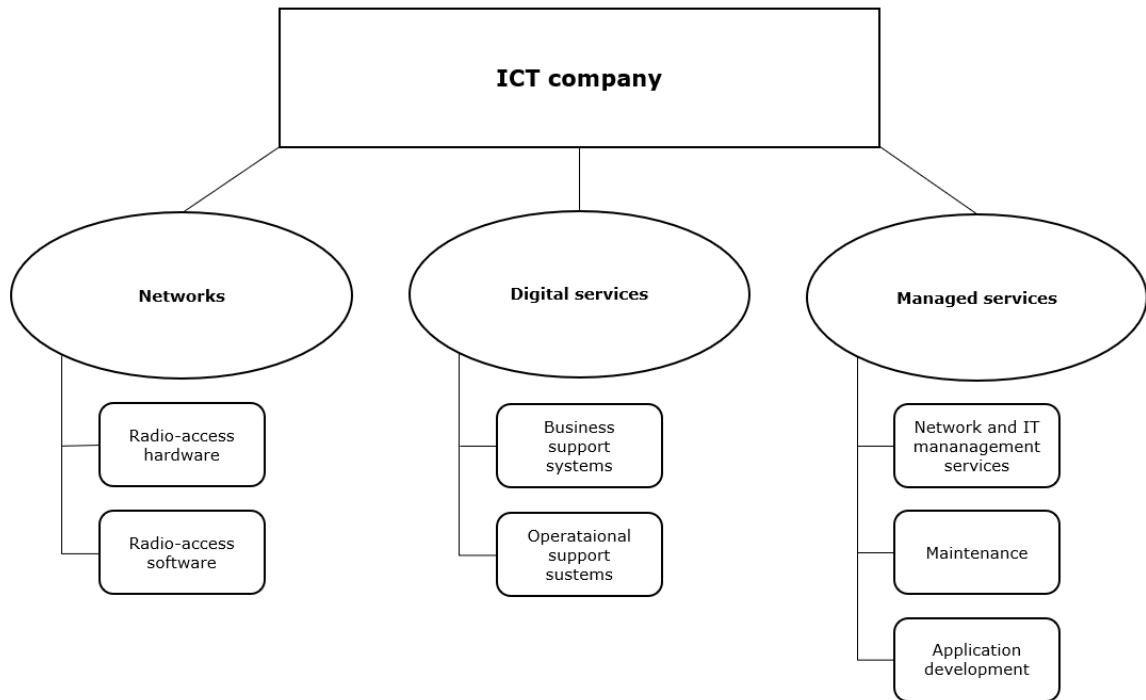

Figure 1.5 Business units of the ICT company and their main activities

As seen from Figure 1.5, the company has three separate business units (BUs), each responsible for its own products and services. As cable assemblies are used in radio-access hardware, then this thesis is related to the activities of the Networks business unit.



Figure 1.6 Examples of radio-access hardware: Nokia Flexi Multiradio 40W RRU and a Nokia Flexi Multiradio 10 radio base station (Nokia)

The BU has their own research and development (R&D) facilities in Europe and Asia focusing on development of RRUs, BBUs, antennas and other hardware units (as shown under Figure 1.6). Software development is mostly outsourced. The manufacturing facilities are distributed globally with sites located in China, India, Europe, North- and South America. Like common in the electronics industry, the model of outsourced manufacturing for products that have reached maturity stage is followed by using contract manufacturing (CM) and electronics manufacturing services (EMS) (Boy, 2002) which helps keeping the fixed costs down (Davis, 2018). The companies active in providing this kind of services are Foxconn, Jabil, Flex, Sanmina (EPSNews, 2020). The ICT company has its own hardware supplier base who, each in their own area of expertise, are constantly competing to be included in new and already developed hardware solutions.

1.2.2 Mobile Networks Market Overview

The mobile networks market is consolidated and shared between three vendors globally which are Huawei, Ericsson and Nokia (Nokia, 2020). Additionally, there are some regional vendors such as ZTE, Samsung, Fujitsu and NEC (*Ibid.*). The estimated market value in 2019 was \$80 billion, forecasted to increase to \$100 billion by 2026 (Wadhvani, Kasnale, 2020). According to Statista, in 2018 the biggest market share belonged to Huawei with 31% followed by Ericsson (27%), Nokia (22%), ZTE (11%), Samsung (5%) and Others (4%).

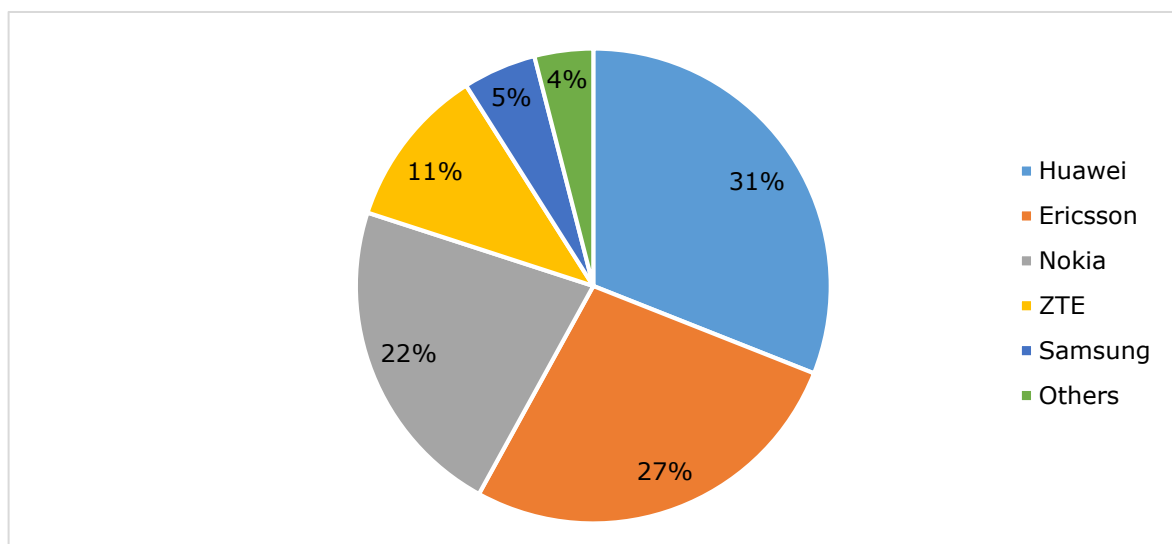

Figure 1.7 Market share of telecom mobile infrastructure companies worldwide in 2018, in percentage (Statista, 2018)

Over the years, the Chinese companies Huawei and ZTE have managed to increase their market share by underbidding competition by 30 to 40% which has been made possible thanks to the subsidiaries of the Chinese government (McCarthy, 2012). For example, during a bidding for 5G wireless network for an operator in the Netherlands, Huawei's offer was 60% lower in price than its competition Ericsson.

The mobile networks market is growing which is driven by the customers of mobile network operators. For example, the total number of mobile subscriptions was around 8 billion in Q3 2019, with a 61 million subscription increase during the quarter and a 3% YoY increase in comparison (Ericsson, 2019). At the same time, the number of mobile broadband subscriptions grew 10 percent YoY, increasing by 120 million in Q3 2019 (*Ibid.*). The total amount of mobile broadband subscriptions is now 6.2 billion or 77% the number of mobile subscriptions. The number of 4G (LTE) subscriptions increased by 190 million during the quarter to reach a total of 4.2 billion, or 52 percent of all mobile subscriptions (*Ibid.*). Subscriptions associated with smartphones account for more than 70 percent of all mobile phone subscriptions (*Ibid.*). As seen from Figure 1.8, in 2025, 90 percent of subscriptions are projected to be for mobile broadband. It is estimated that there will be 8.9 billion mobile subscriptions by the end of 2025, out of which around 90 percent will be for mobile broadband (*Ibid.*).

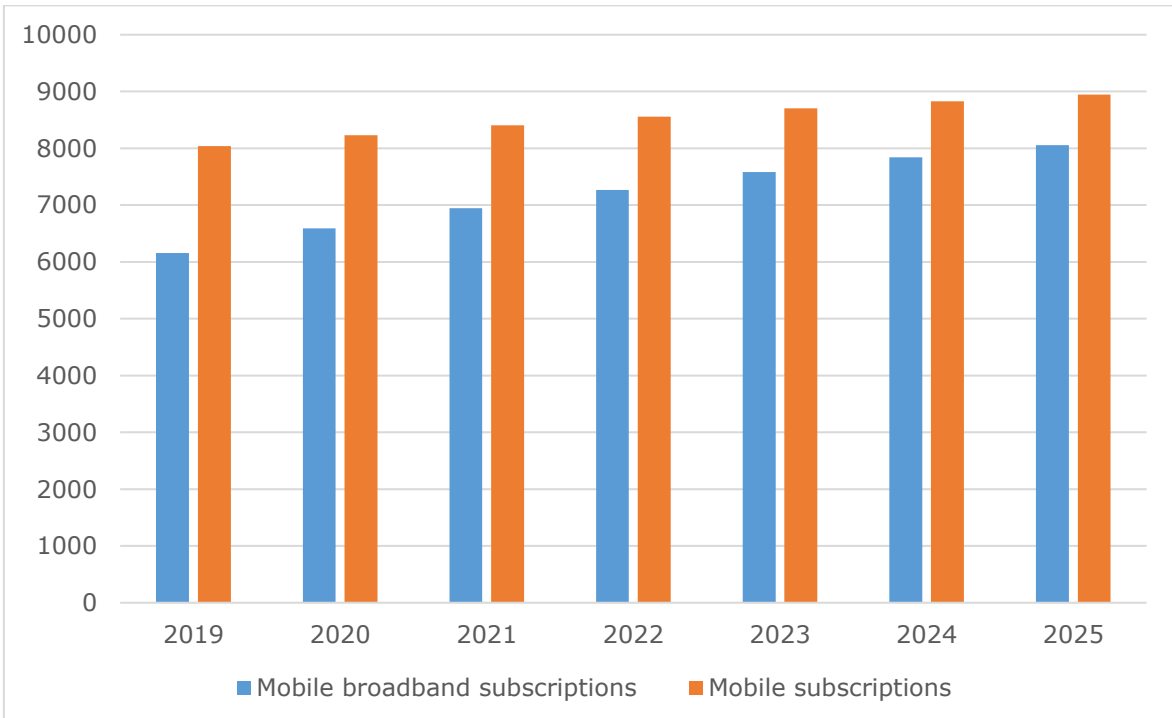

Figure 1.8 Forecasted number of mobile broadband subscriptions and mobile subscriptions between 2020 and 2012, in millions (Ericsson 2019)

Because the smartphone users that are increasingly substituting the mobile Internet with fixed Internet, the demand for mobile data traffic is increasing rapidly. Once having experienced the benefits of mobile data access on their smartphones, the users want to use it in their mobile devices. This includes all kind of media, anytime, anywhere. Although it is concluded that consumers only adopt mobile Internet services that strongly resemble the services they already use on the fixed Internet, substitution effects between mobile and fixed Internet are already in place (Feijóo *et al.*, 2016). For instance, mobile data traffic grew 68 percent between Q3 2018 and Q3 2019, from approximately 22 exabytes to 37 exabytes and is expected to continue to grow 27% annually between 2019 and 2025 (Ericsson, 2019). By category, the growth in mobile data is driven by audio/video, social networking, web browsing (Feijóo *et al.*, 2016).

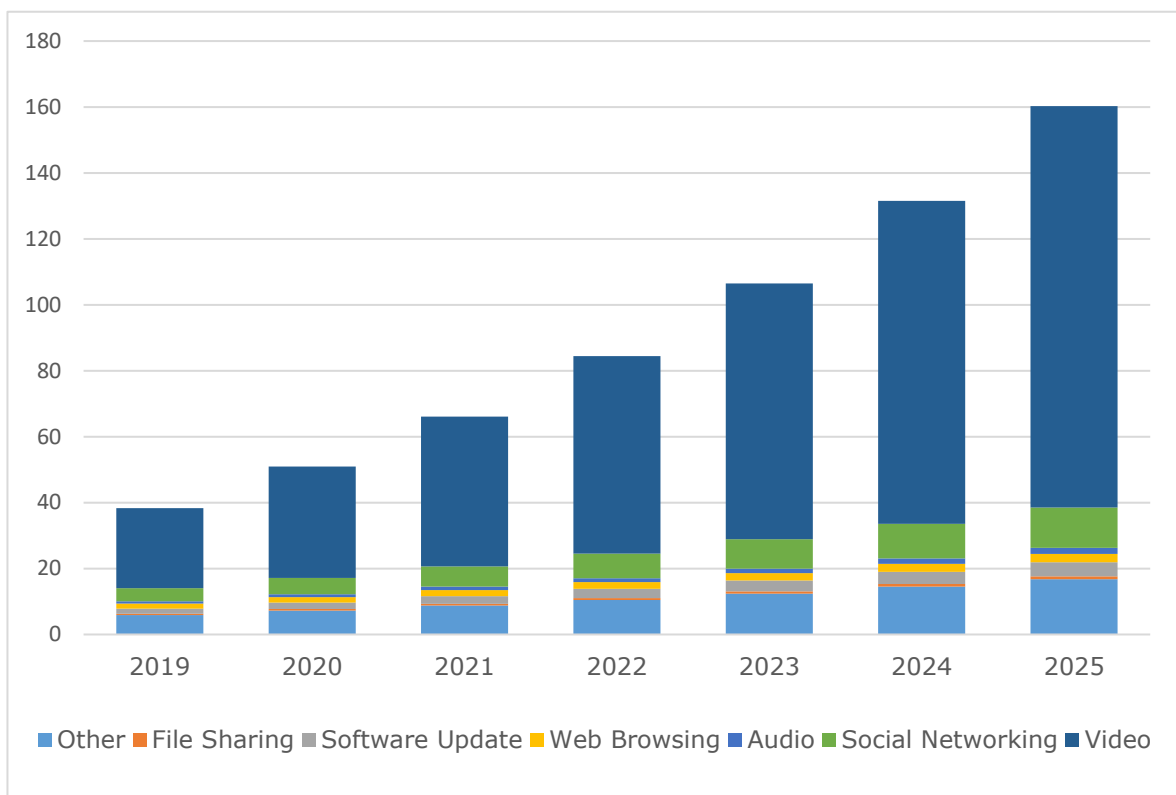

Figure 1.9 Forecasted mobile data traffic usage by application category between 2019 and 2025, in exabytes (Ericsson, 2019)

In order to keep up with the increasing customer demand, the operators have no other choice than to invest into their networks (Feijóo *et al.*, 2016). This, however, is complicated as the margins of the operators have been constantly decreasing due to intense competition (Fonseca, Gorter *et al.*, 2019) making the operators to look for cheaper, cost efficient solutions.

1.3 Cable manufacturing company

1.3.1 Operations, products and services

The described manufacturing company is a world leading company in designing and manufacturing connectivity and sensor products for harsh environments in a variety of industries, such as automotive, industrial equipment, data communication systems, aerospace, defence, medical, oil and gas, consumer electronics and energy. The company described has an annual revenue of about 15 billion USD and is divided into three main business segments:

- 1) industrial solutions;
- 2) communication solutions;
- 3) transportation solutions.

The Industrial Solutions segment provides products that connect and distribute power, data and signals. The Communications Solutions segment supplies electronic components for home appliances, data centres, wireless networks, different electronic devices. The Transportation segment is supplying products that are used by the automotive industry for body and chassis systems, driver information, convenience applications, infotainment, engine and powertrain applications, safety and security systems.

The studied signal cable assemblies are provided by the Communication solutions segment. the main products of this segment being the following:

- radio frequency (RF) connectivity solutions;
- input/output (I/O) connectivity solutions;
- fiber optic connectivity solutions;
- board-to-board (BtB) connectivity solutions;
- power solutions;
- modular connectivity solutions;
- antennas.

The segment has R&D centres in North America and China. Manufacturing is mainly done in China but there are also factories in India, Europe and North America. In cases where the product is not falling under a core competence of the company a PBL (Performance-Based Logistic) contract is being used to lower production related costs (Sanders, Ellman, 2018). For the cable assemblies, the lead engineering site is located China. This where most of the raw material suppliers are located, also engineering teams, production workers. The biggest customers of the communications segment

include Ericsson, Nokia, Cisco, Google, IBM, HP, Facebook, ZTE, Huawei, Dell. The company has been a supplier to the described ICT company for at least 40 years.

1.3.2 Cable assembly market overview

The global cable assembly market is divided between several manufacturers. As there are several types of products with specific usage or functions available, the market is segmented based on product. It includes sub-segments such as application-specific, rectangular, RF (radio frequency), circular and others. The product outlook overview is the following: automotive, consumer electronics, telecom and datacom, industrial, others (Infiniti, 2020).

The overall market size was estimated to be 146.6 billion USD in 2017 and is predicted to grow to 198.5 billion USD by 2022. (Bishop, 2017). At the same time, telecom and datacom portion of the business was 25.8 billion USD and is expected to reach 37.2 billion USD, respectively. Both values are visible in Figure 1.11 which shows that the growth pace of telecom market area is slower than total market. Availability of counterfeit and grey market products, mainly from the Chinese manufacturers, is one main key restraints to the market growth (Infiniti, 2020) as they are cheaper and, as a result, slowing the market growth. Some of the key players in the cable assembly market are Amphenol, TE Connectivity, Luxshare, Koch Industries (Molex), Gore, Samtec.

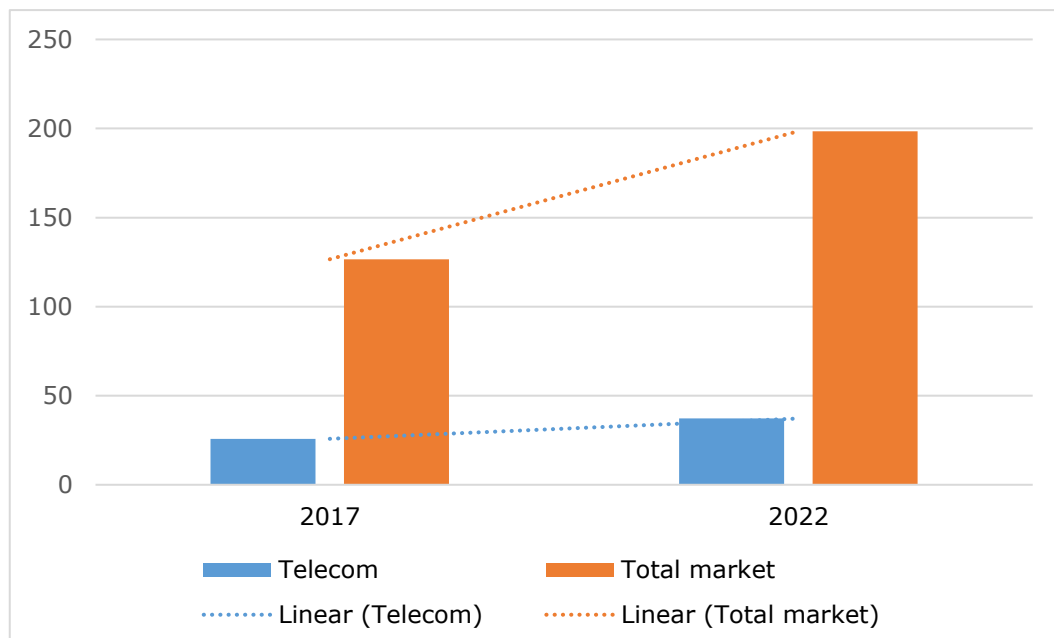

Figure 1.11 Cable assembly market size by area in 2017 and 2022, in billions USD (Bishop, 2017)

1.4 New product development theory

New product development (NPD) covers the complete process of bringing a new product to market (Collins dictionary). It can be understood as the transformation process of a market opportunity into a product being manufactured, delivered and available for sale (Ulrich, Eppinger, 2012). The product itself can be tangible (something physical that can be touched) or intangible, like a service or an experience (Kahn, 2005). NPD requires an understanding of customer requirements, the competitive environment, and the nature of the market (*Ibid.*). The main variables driving the customer needs are product cost, development time and product quality (Ulrich, Eppinger, 2012).

As technology is continuously advancing and market needs are constantly changing, companies need to develop continuous practices and strategies to better satisfy customer requirements and to increase their own market share by a regular development of new products (Kahn 2005). There are also a lot of uncertainties and challenges which companies must face throughout the process. The company can overcome them by using best practices and eliminating communication barriers by using an effective strategy that includes the following ingredients (*Ibid.*):

1. **The role of NPD in achieving the overall businesses goals** - goals of NPD business goals should be linked to the overall business goals, so that the role of NPD in achieving business goals is clear;
2. **Clearly defined NPD goals** — the best practice suggests that a business should clearly define its longer-term goals for new products—for example, what percentage of the business's sales or profits or growth is expected to come from new products over the couple of years;
3. **Definition of strategic arenas** — areas of strategic focus on which to concentrate NPD efforts on;
4. **Strategic buckets** — studies of portfolio management point to earmarking resources targeted at different project types or different strategic arenas to ensure strategic alignment of NPD with business goals;
5. **Product roadmap in place** — a product roadmap is an effective way to map out a series of initiatives in an attack plan and making sure that the resources are in place when needed;

6. **Long-term commitment** — answering questions like “Does the business have a long-term view of its NPD efforts?” and “Is product development largely a short-term effort, with an absence of longer-time-horizon projects?”;
7. **More innovative projects** — best-performing businesses undertake a higher proportion of innovative NPD projects.

Product development is an interdisciplinary activity that requires contributions from almost all the functions of the company, almost always including the following the following functions: marketing, manufacturing and design as seen from the Exhibit 1 below (Ulrich, Eppinger, 2012). Other functions include sales, legal, finance.

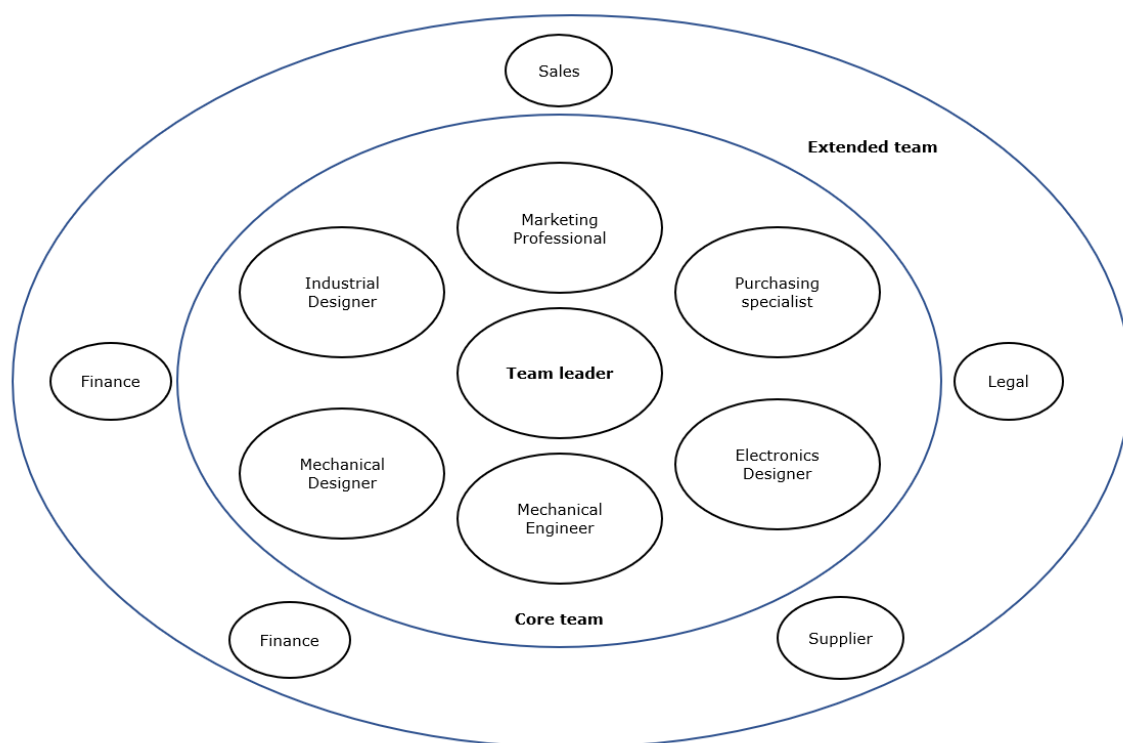

Figure 1.12 Product Development Team (Ulrich, Eppinger, 2012)

Assigning a project manager, also known as team leader to be accountable for each phase is useful for the organization as it creates preconditions that the project is constantly followed up. This individual must recognize the skills needed to successfully complete the tasks and must involve the effective personnel to each phase. The project manager, working together with the marketing and sales team, develops the design objectives, generates a multi-year sales forecast, and sets price levels. The design objectives must be clearly defined, and an assessment must be made of the sales capabilities to fully understand and promote the new product. Different team members may be necessary during each development phase (Garver, 2014).

The product development process usually consists of the following development stages are (*Ibid.*):

1. **Fuzzy front-end (FFE)** is the messy “getting started” period of product development, when the product concept is still unclear. Preceding the more formal product development process, it generally consists of three tasks: strategic planning, concept generation, and especially, pre-technical evaluation. These activities are often chaotic, unpredictable, and unstructured (Kahn, 2005);
2. **Product design** or engineering phase is about product development with the goal to meet the requirements. ICT companies usually require customized products which are slight variations of already existing products (Ulrich, Eppinger, 2012). The design typically has the most overlap with the engineering design process but can also include industrial design. On the marketing and planning side, this phase ends at pre-commercialization analysis stage. It is of great importance that the involvement of all engineering disciplines, including design, product, manufacturing, materials management, and marketing personnel, communicate with each other during this activity (Garver, 2014);
3. **Product implementation** or manufacturing phase often refers to later stages of detailed engineering design, as well as test process that may be used to validate whether the prototype meets all design specifications and performance requirements that were established. The product design is well documented, and the detailed drawings are completed both for the product and tooling. All manufacturing tooling should be completed, and vendors established. (Garver, 2014);
4. **Commercialization** or release phase represent the action steps where the production and market launch occur. Direct sales or distribution personnel need to be fully armed with the appropriate samples, literature, test data, documentation, and training to effectively communicate the product features and advantages to the prospective customers (*Ibid.*).

Some months after the finalizing the commercialization product phase, the post launch review occurs: the performance of the project versus expectations is assessed along with reasons why events occurred and what lessons were learned. The project team is then disbanded and the project is terminated (Kahn, 2005).

1.5 Conclusions

The growth of mobile networks market is driven by the users of mobile network operators as more and more mobile data is being used. To keep up with the increasing customer demand, the operators have no other choice than to invest into their networks (Feijóo *et al.*, 2016). Making heavy investments is increasingly complicated as the margins of the operators have been constantly decreasing due to intense competition (Fonseca *et al.*, 2019) making the operators to look for cost efficient solutions for their networks, with cheaper hardware solutions being a priority.

Price pressure from the operators and the unfair competition by the Chinese companies Huawei and ZTE is making the companies like Ericsson and Nokia to bring their prices down as well. As cable assemblies are a vital part of the cellular network infrastructure then and are required to be cost-effective, counterfeit and grey market cable assemblies are increasingly thriving (Infinti, 2020). All of the above is adding price pressure to the big cable manufacturing companies such as Amphenol, TE and Luxshare pushing them to come up with new cost-competitive solutions. This challenge is mainly tackled during the fuzzy-front end and product development processes with little room of error.

2 METHODOLOGY

2.1 Research strategy description

This master thesis is by nature a case study. It can be understood as one a comprehensive in-depth analysis based on the context of a specific unit, where the author defines the work as analysis of customer specific signal cable development to an international ICT company that is providing hardware solutions for cellular networks.

The author plans to use qualitative and quantitative methods when writing the thesis. Based on the main objective of the dissertation, which is to find out what kind of changes need to be made to current ways of working at the cable manufacturing company to meet expectations of a company providing hardware solutions for cellular networks, the author must first get acquainted with the object under study, collect comprehensive information and then analyse the gathered information. Then the author of the thesis must present the object in its integrity and bring out its uniqueness (Strömpl, 2014).

The research strategy of the work is the case study method, which is used to describe the context author of both quantitative and qualitative data (Virkus, 2010). The first of these involves statistics as well as various numerical values published by other authors. Such the way information is collected stems from the goal of bringing together as much and diverse as possible information about the research object (Strömpl, 2014), which in this dissertation is a new set of signal cables developed especially for an anonymous international ICT company. Qualitative data is collected by searching for information from various relevant texts such as documents, studies, research articles, dissertations but also from gathered responses out of a survey.

The author of the present thesis uses the combination of both case-based (vertical) as well as cross-case (horizontal) analysis techniques. Based on collected data the author performs an analysis within the case, based on which calculations are performed, conclusions and suggestions are formulated (Kalmus et al., 2015).

2.2 Overview of data sources and survey analysis

The author of the dissertation has mostly collected the data used in this master's thesis from sources where information is presented in the English language. The author has also verified that the sources of input data are as new and official as possible in order to maintain the objectivity and achieve the topicality of the of the dissertation. Most information used to describe and analyse the case study of developing customer specific signal cable assemblies to an international ICT company has been collected by preparing a questionnaire and carrying out a survey. The survey was conducted as the author was not granted the permit of sharing internal data including documents, presentations and e-mail exchanges that could link the thesis back to the cable manufacturing company.

The survey was carried out based on the principle of convenience sampling within the people that were mostly involved in the project and are colleagues of the author, all employed by the cable company. The method of convenience sampling was used due to the simplicity of collecting the needed information (Öunapuu, 2012).

The questionnaire was sent out to 12 people with different job positions within the anonymous cable manufacturing company via e-mail in a Microsoft Word file format. In total, there were 5 question blocks and 49 open-ended, substantive questions (Beilmann, 2020), most of them being investigative to find out as much as information as possible (Ginzburg, Sag, 2000). Out of the 12 questionnaires that were sent out, the author received a reply from 8 people making the total response rate 66.7%. The questionnaire is visible in Appendix 1.

The questionnaire started with collecting background information and consisted of 8 questions with the specific purpose of providing the overview of respondent's job role, experience at the company and the employer itself. Some examples of the questions were:

- "Please name some of the main job responsibilities that you have at your current job position" (IIT);
- "How many years have you been working at your current position?" (OECD, 2013).

At the time of reply, the average respondent had been working at the cable manufacturing company for 9.5 years and for 4.1 years at their current position. Two of the respondents were employed as field application managers, two as product managers and another who as product development engineer. Furthermore, one of the respondents worked as an account manager and one as a product manager.

The second block covering new product development within the company block was made up from 8 questions investigative covering the implemented internal NPD processes, mapping of the people involved and personal opinions on the processes. The respondents were asked to describe the internal NPD process, if they were a part of the NPD processes who do they work with, if the processes are clear to them, their opinion on them and how long does it usually take to develop a new cable assembly (Tufts, 2020).

While all the 8 respondents reported to be involved in the NPD process, it turned out that the whole process was clear for only 50% of them. The answers also revealed that it usually takes 3-6 months to develop a new cable assembly. Feedback and proposals the respondents brought out about the internal NPD processes are presented in Table 2.1 below. It was concluded from the collected feedback that the cable manufacturing company is successful in process management but is not agile in execution

Table 2.1 Feedback on current NPD processes and improvement proposals

Pros and cons of current NPD process	Common bottlenecks in development of CAS	Proposals to improve current NPD process
<ul style="list-style-type: none"> + clear business case requirement + strict milestone review + documentation + project follow-up process 	<ul style="list-style-type: none"> • lack of competent suppliers • technical solution freeze • not enough information for a clear business case 	<ul style="list-style-type: none"> • focus on customer prioritization • enhancement of testing capabilities • update supplier base
<ul style="list-style-type: none"> - lack of agility - high cost - lack of internal commitment on project 		

Investigative questions (Ginzburg, Sag, 2000) covering the process of setting up an internal business case for new products consisted of 8 questions and were put together with an aim to get an overview of building a business case, the approval process of the business case, and the role of the respondents. Some examples of the questions were:

- "What are the main requirements to get a business case approved.";
- "Who is responsible for initiating an internal business case? What kind of information is needed to initiate one? What is done after the business case has been set up?".

Table 2.2 Internal requirements of building and approving a business case

Required information to build a business case	Key metrics of approving a business case
<ul style="list-style-type: none"> • Forecast • Target pricing • Expected price erosion • Project timing • Product lifetime expectation • Development cost • Own cost • Expected revenue 	<ul style="list-style-type: none"> • Profitability • Required size of investment • Project payback time • Fit to existing product portfolio

The fourth question block contained 10 questions that were constructed to receive an overview of respondent’s interactions and knowledge of the ICT customer. The investigative questions were covering flow of information, customer requirements and expectations towards their employer, history with the customer, customer satisfaction, strengths and weaknesses of the cable manufacturing company. Out of the 8 respondents, 4 reported to have any previous experience with the customer. The notable outtakes of this question block are presented in Table 2.3.

Table 2.3 Respondent feedback on customer requirements, strengths and weaknesses of the cable manufacturing company

Customer requirements on products and service	Strengths of cable company towards customer	Weaknesses of cable company towards customer
<ul style="list-style-type: none"> • Withstand operating in harsh environments • Customized/unique solutions • Compliance to safety standards • Aggressive pricing 	<ul style="list-style-type: none"> • Technical competence • Universal processes • Brand value 	<ul style="list-style-type: none"> • Lack of agility • Long NPD time • Pricing • Lack of internal accountability

The last 15 questions from the last question block were specifically aimed to cover the case under analysis. The respondents were asked questions about the development of the customer specific RJ45-RJ45 signal cable assemblies: what the customer requirements were, end-usage of the product, project timeline, challenges during product development and opinions on what could have been done differently. Out of the 8 respondents, 2 people answered to these questions. The main takeaways are presented in Table 2.4. Additionally, one of the respondents also provided the author materials covering customer specifications of the signal cable assemblies, bill of material (BOM) of the assembly as a separate attachment while the other provided the author an overview of manufacturing and distribution process steps visible in Table 2.9, input to perform profitability analysis (figures brought out in subchapter 3.2).

Table 2.4 Main reported causes of project delay and key takeaways from the case

Main internal causes of project delay	Main external causes of project delay	Lessons learned
<ul style="list-style-type: none"> • Uncertainty who is responsible PM • Low input data quality 	<ul style="list-style-type: none"> • Unique technical requirements • Misleading information from customer regarding possible cable vendors 	<ul style="list-style-type: none"> • Update supplier base • Deeper involvement by internal stakeholders

2.2.1 Development process overview of new cable assemblies

Receiving information from the customer

Receiving information from the customer is most common as the customer is driving the design and specification of the cable assemblies. Customer requests are usually received over an e-mail as an RFQ (request for quotation) or an RFI (request for information):

- an RFQ usually consists of customer specifications, an annual demand forecast and a target price, if available. In exchange, the customer expects to receive an official quote from the cable manufacturing company;
- an RFI is consisting of a ballpark demand forecast and requirements of the product, including key performance requirements and dimensions. The expected feedback is usually a technical solution including the product drawing, specs, performance metrics and a quote.

After an RFQ or an RFI, it is first evaluated if the company has the capability and willingness to pick the opportunity up. After a positive decision, the FFE development stage starts.

Customer requirements on a signal cable assembly

The main specifications for (signal)cables can be divided by into the following categories:

- connector – interface, performance;
- cable – conductors, shield material, diameter;
- dimensions – length;
- visual appearance– colour of cable and wires. labelling, markings on cable;
- mechanical parameters – bending radius, tensile force, connecting operations;
- electrical performance – attenuation, return loss, resistance, delay skew etc;
- safety – operating temperature range, certificates (UL, CPR), no usage of banned substances; water and dust resistance.

Usually the cable assemblies are custom built, many using standard interconnect components in combination with a unique cable, configuration, packaging and labelling meaning that development process is not as costly as developing a completely new solution. The cable assemblies are usually meant to be used outdoors or in an uncontrolled environment and, therefore, must endure rugged handling and withstand harsh working environments, generating extra the cost. In most cases, the newly developed products are extensions to existing products but as the process still involves some levels of customization (including usage of new raw material), technical changes, the development needs to be handled as a standalone engineering project.

Customer expectations on service

Agility and technical competence are valued the most by the ICT customer. Also, the offered product is expected to have an aggressive price, meet the industry standards/compliances, fulfil the electrical, mechanical and safety requirements. The customer usually wishes to receive a quote and a proposed technical solution within a week. In case the pricing and concept is acceptable, fully operational samples are expected within 8 weeks from sending out the RFQ meaning that the company has to be agile throughout the FFE and product development stages.

Building an internal business case

According to the respondents, the internal business case starts with the responsible sales team who is responsible for setting up the internal business case after receiving the information from the customer. Their input needs to include technical and business requirements specifying the product specifications, product life-cycle, end-customer, end application, target price. After the business case is set up, it's being sent to a product management who also acts as the first gatekeeper within the process and decides whether it makes sense to continue with the project or not. If more information is needed, the project is pushed back to the sales team.

After the project has been accepted by product management, then the information about the project will be forwarded to a project team consisting of a project manager (PjM), product development engineer (PDE), procurement. The project management team is defining the project internally by doing the following steps:

- 1) Defining the product by creating internal specifications;
- 2) Estimating the length of the project;
- 3) Calculating a cost estimate of carrying out the project;
- 4) Calculating the unit cost of the product;
- 5) Calculating expected revenue stream.

The whole process is coordinated by the responsible project manager and product manager. Functions and their responsibilities are visible in Table 2.5.

Table 2.5 Functions of internal teams involved in internal business case process

Function	Responsibilities
Sales	Communication with the customer, building and distributing internal business case
Product management	Defining the business case (financials), driving business case with internal stakeholders (project manager, product development engineer, PAC)
Product development engineer	Product development (specifications, design, BOM)
Project manager	Driving project, presenting projects and asking resources from PAC
Procurement	Raw material procurement (suppliers and cost)
Project Approval Committee (PAC)	Evaluating projects, allocating resources to project (engineering hours, budget)

Project approval process

After the project has been defined, it is taken to the project approval committee (PAC) who is responsible approving the project, for allocating resources (engineering hours) to the project and approving proposed budget. The committee consists of senior management of the company and comes together once a week. The project is mainly assessed based on P&L (profit and loss) calculations, operating and standard margin, net present value (NPV), internal rate of return (IRR) and payback time. However, the strategical value of the project is also valued, both by evaluating the product fit into the current product portfolio and whether the product is used in strategically important end-products.

In case the project will not pass PAC, then the project will either be terminated, or the cost estimates and commercial input will be updated after which it will be taken again to PAC.

Sample production and testing

After getting the approval from PAC, the project team will start working towards development and production of samples. This stage usually requires completion of production tooling and availability of (certified) raw material. The biggest bottleneck of this process is usually the certification process of the raw material which can take up to 2 months. The qualification testing is done following the customer requirements and it usually takes 2-3 months from receiving the RFQ to send out first batch of samples.

As the products are usually unique and there is a high variety of different solutions, the cable assembly manufacturing processes still mainly relies on manual assembly as the

customization is more cost-effective. Although, some automation can still be incorporated into the manufacturing process, for example wire cutting (Jem Electronics, 2018).

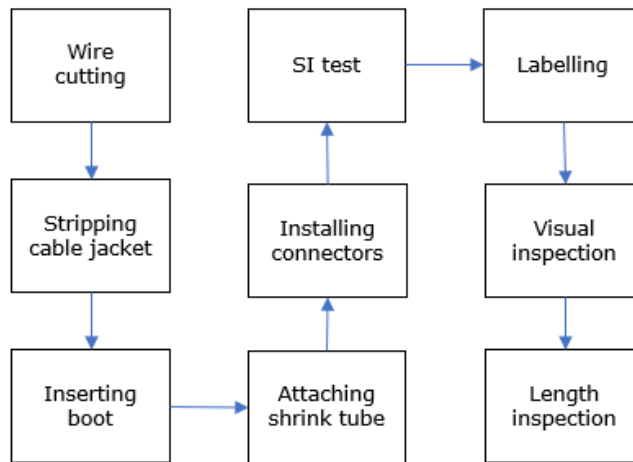

Figure 2.1 (Sample) production and testing process (Jem Electronics, 2018)

As visualized in Figure 2.1, the production and testing process of (signal) cable assemblies consists of 8 stages, 5 of which are related to production and 3 to testing and quality assurance. **Wire or cable cutting** is the initial step in building cable assemblies, where the wires are cut to the specified length, which is done by a wire-cutting machine. The next step, **stripping cable jacket**, requires that the wire ends must be stripped for the cores to be exposed. This is followed by **inserting the boots** for the connectors and **attaching a heat shrink tube** used to cover exposed wires or smoothen out any sharp edges on the cable. The **installation of connectors** is usually done by connecting the stripped wire ends to the connector through the process of crimping and/or soldering after which the connector is fastened to the rest of the cable through the process of insert molding. Testing of the cable assemblies is done according to ISO/IEC 11801-1:2017 standard, while common standards for the production facility are the ISO 9000 standard (quality management) and ISO 1400 (environmental management). The end-result of the described process is expected to be a product that meets all the customer requirements.

Product approval by the customer and production ramp-up

After the samples have been manufactured, they are sent to the customer for inspection and testing. Alongside the customer will receive with documents such as container files, including product drawings, customer requirement compliance report, bill of material and material declarations. Once the product has passed the tests carried out by the customer and the documentation has been declared to meet the set requirements, the

product will be approved. Then the customer can start sending their forecast to the cable manufacturing company which is initiating production orders in the enterprise resource planning (ERP) system such as SAP. By that time, the part needs to be set up in the system and connected to the end-customer. Product approval also marks the end product implementation phase and the start of commercialization.

2.2.2 Overview of developing new RJ45-RJ45 signal cables to the ICT company

A request for quotation (RFQ) for two versions of RJ45-RJ45 cable assemblies (24 AWG and 26 AWG) was received from the ICT company on March 21st, 2019. The RFQ consisted of the customer PNs, including an initial forecast for each of the cable assemblies, and the information regarding the end-usage. Customer specifications visible under Figure 2.2. were made public later, on April 26th.

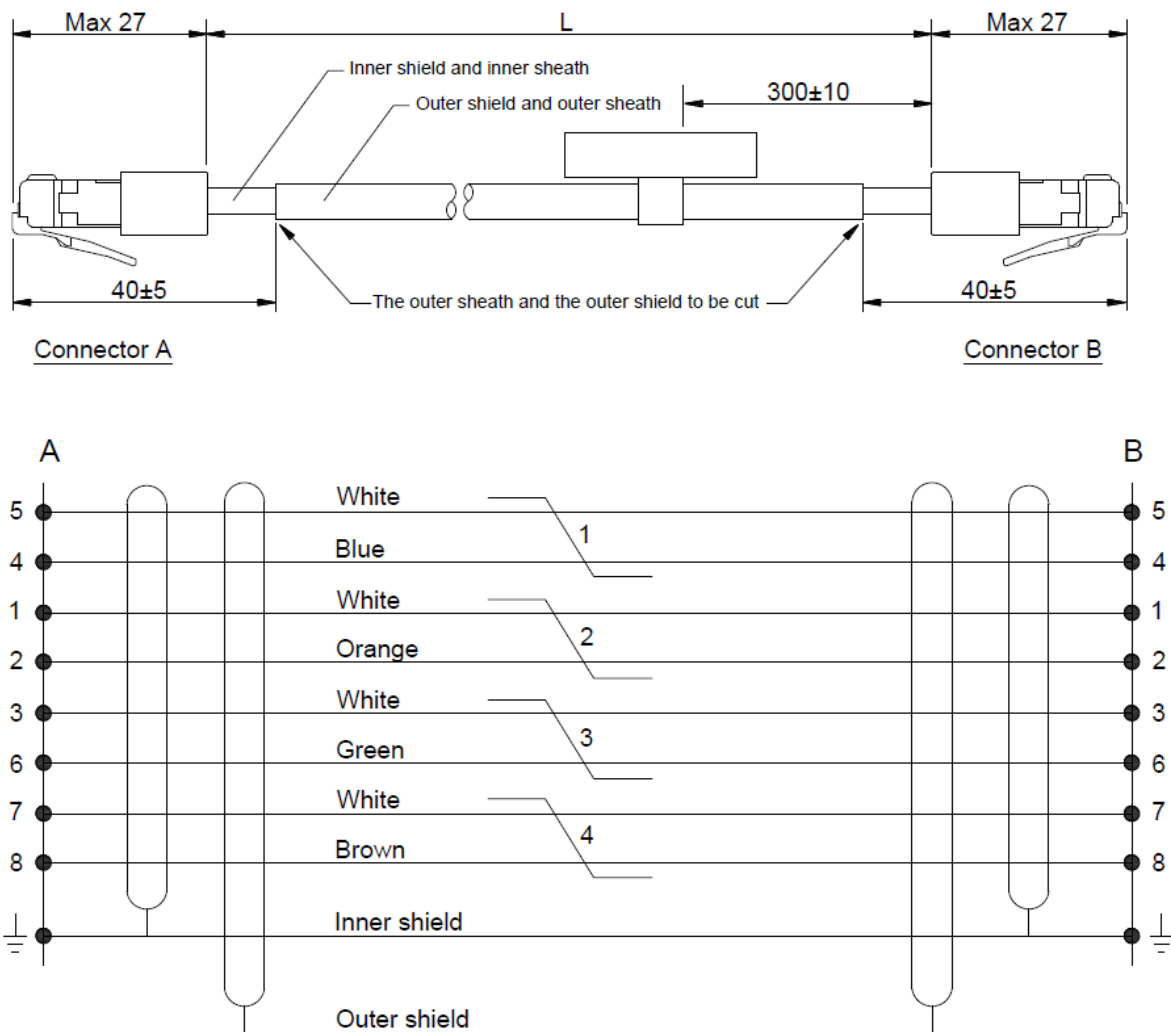

Figure 2.2 Drawing of RJ45-RJ45 signal cable with colour requirements and connection positions of the wires

Both signal cable assemblies had series of requirements divided into different categories. Some of them are presented in Table 2.6 below:

Table 2.6 Customer requirements for RJ45-RJ45 signal cables

Category	Parameter	24 AWG cable assembly	26 AWG cable assembly
Connector A	Shielded 8 position RJ45 plug	CAT5E or better performance	
Connector B	Shielded 8 position RJ45 plug	CAT5E or better performance	
Cable	Jacket color	Black	
	Conductor	24 AWG	26 AWG
	Inner shield material	Copper	
	Outer shield material	Copper	
Dimensions	Length	3 m \pm 1%	
	Cable diameter	7.5 mm \pm 0.3 mm	6.8 mm \pm 0.2 mm

Other requirements included CPR, UL1685 certification, a requirement to have double shielding to withstand lightning, low smoke zero halogen (LSZH) isolation. The entire list of customer requirements is presented in Appendix 2. It was communicated that they should withstand harsh conditions and the cables are meant to ensure an alarm connection between a controller and an alarm unit in one of the new types of RRU's developed and launched by the customer.

According to the input received from the survey respondents, the cable assemblies were going to be sold as an optional solution to the telecom companies. The annual forecasted units over the product life-cycle were communicated to be the following:

Table 2.7 Demand forecast of RJ45-RJ45 signal cables

Cable type	Annual forecast [pcs]						
	2020	2021	2022	2023	2024	2025	2026
24 AWG	13000	18500	25000	25000	15000	5000	2500
26 AWG	13000	18500	25000	25000	15000	5000	2500

After business case was set-up internally by the sales team, the project was picked up by the responsible product manager on May 5th because it was seen as a good fit to the existing product portfolio. The product manager then took the information provided by sales, send the data to the development engineer and project manager who initiated an internal project. The project was presented to PAC who granted the project the needed resources to carry out the project. In parallel, a quote was already sent out to the customer on June 4th, 2019 based on the customer specifications based on which a preliminary award was received about a week later. However, the project team

struggled to find a supplier that could provide a raw cable that could meet all the requirements. As a result, the cable had to be developed anew and later certified.





The first set of samples were sent out to the customer on September 19th, 2019, but at the time the cable assembly did not have the necessary UL and CPR certificates. The aim of sending the first set of partially non-compliant samples was to find out if they met other customer requirements (mechanical, electrical). The partially non-compliant samples passed and, as a result, a preliminary product approval and a final award decision was made by the customer. The process of UL and CPR certification took a few months and, consequently, a set of fully compliant samples were produced and shipped at the end of December 2019. The RJ45-RJ45 signal cables, alongside with the material declarations and container files were all approved by the customer by January 31st, 2020. In summary, it took about 10 months for the cable company to develop the cable assemblies and complete the project. The final versions of developed RJ45-RJ45 signal cable assemblies are produced out of 6 different raw material items.



Table 2.8 BOM of developed RJ45-RJ45 signal cable assemblies

Item	24 AWG cable	26 AWG cable	Units	Quantity
1	Heat shrink tubing, with adhesive, L = 1"		pieces	2
2	Connector, RJ45, 8P8C		pieces	2
3	CAT5E, 4P*24AWG, double shield & jacket, black	CAT5E, 4P*26AWG, double shield & jacket, black	meters	3
4	Copper foil		meters	3
5	T-label		pieces	2
6	Boot		pieces	2

The manufacturing, testing and distribution process of the cable assemblies process is consisting of 14 different steps in total which are described and visualized in Table 2.9.

Table 2.9 Manufacturing and distributing process steps of RJ45-RJ45 signal cables

Item	Process	Illustration
1	Cable cutting	
2	Stripping outer jacket	
3	Cable preparation	-
4	Stripping middle jacket	-
5	Reorganizing cable	-
6	Inserting boots	
7	Adding shrinking Tube	

Item	Process	Illustration
8	Installing/Crimping connectors	
9	SI Test	 <small>Figure 1: Patch Cord Testing</small>
10	Labelling	
11	Appearance inspection	-
12	Length inspection	-
13	Packaging	-
14	Shipping	-

2.3 Economic calculations

Analysis period

Based on the estimated product life-cycle presented in subchapter 2.2.2, the analysis period presented in the financial statements and calculations is from the beginning of calendar year 2020 until the end of calendar year 2026.

Profit and loss statement

To get a more accurate idea of the financial costs and revenues associated with the project, the author of the work prepared a profit and loss (P&L) statement for the cable production company covering the life-cycle of the product which reflects the effect of management's operating decisions on business performance and the resulting accounting profit or loss for the cable production company (Helfert, 2001).

The P&L statement displays the revenues recognized for a specific period, and the costs and expenses charged against these revenues, including write-offs like depreciation and amortization of various assets, and taxes. Revenues and costs include the following elements (*Ibid.*):

- sales for cash or credit;
- purchases of goods for resale or manufacture, or cost of services provided;
- general and administrative expenses;
- sales and marketing expenses;
- research and development costs.

All financial statements have been prepared on the basis of collected data from the cable manufacturing company. The author of this thesis emphasizes that all the values obtained in these reports are forecasts by nature and should not be purported to the absolute truth. Their purpose is to give an idea of the financial magnitudes of developing a set of RJ45-RJ45 signal cables to an ICT customer. The author uses real values obtained by considering the annual inflation factor obtained from OECD. The financial statements are prepared by the author in Microsoft Excel.

Project profitability model and financial metrics

The methodology of the financial analysis for the RJ45-RJ45 signal cables is mainly based on the European Commission's Guide to Cost-Benefit Analysis of Investment Projects. The author uses the above instructions from the above-mentioned guide for conducting a financial analysis to calculate the return of investment to the company.

Based on the guidelines issued by the European Commission, the author performs the calculations with real prices, using the concept of the time value of money, in the course of which the author calculates all direct financial costs associated with the development and production and logistics, plus income from sales related to the cables (EC, 2014). In the calculations, it is assumed that the cable manufacturing company will cover all the costs related to the project, including non-recurrent engineering (NRE), certification costs of the final product, logistics, unforeseen extra costs, operating costs, working capital costs.

While carrying out the financial analysis, the author first calculates the forecasted sales revenues and costs related to engineering, material, labour, overhead, logistics, followed by operating costs, -margins and working capital in real time prices by using an annual inflation rate issued by OECD in 2020.

The working capital is covering short-term liquid assets remaining after short-term liabilities have been paid off. The liquid assets include cash, inventory and accounts receivable while the liabilities include accounts payable, short-term loans (CFI). Having positive working capital can be a good sign of the short-term financial health of a company because it is an indication of enough liquid assets remaining to pay off short-term bills and to internally finance the growth of its business. A negative working capital means that assets are not being used effectively enough and that the company may face a liquidity crisis. Even if a company has a lot invested in fixed assets, it will face financial challenges if liabilities are due too soon. This may lead to more money borrowing, late payments to creditors, as well to suppliers resulting in a lower corporate credit rating (*Ibid.*).

Net present value is defined as the amount obtained when discounted expenses are deducted from discounted income. It is calculated with the following formula (EC, 2014):

$$FNPV = \sum_{n=1}^{\infty} a_t S_t \frac{S_0}{(1+i)^0} + \frac{S_1}{(1+i)^1} + \dots + \frac{S_n}{(1+i)^n}, \quad (2.1)$$

where S_t – cashflow balance during time period t,

$a_t = \frac{1}{(1+i)^t}$ – discount rate during time period t,

i – WACC.

A positive NPV indicates that the project is profitable while the negative NPV is showing the opposite.

The internal rate of return (IRR) or financial return on an investment, is defined as the discount rate, where the monetary net present value is zero (Alver, Reinberg, 2002). This is equivalent to the original expenditure at net present value of income. The value is obtained with the following formula (*Ibid.*):

$$0 = \sum \frac{S_t}{(1+IRR)^t}, \quad (2.2)$$

where S_t – cash flow balance at time period t,

IRR – internal rate or return.

While calculating the reasonable profit margin, the author of the dissertation is following the basic financial theory according to which the value of the value of IRR be equal to WACC (Zyla, 2019).

Payback is measured by the number of years required for an investment to return the initial investment. Projects with a shorter payback period by this analysis are regarded more favourable because they allow the resources to be reused quickly. Also, the shorter the predicted payback period, the less uncertainty is involved in receiving the returns (Liebermann *et al.*, 2013). The author is considering the project potentially successful if the payback time is less than half of the product life-cycle which is 7 years.

Sensitivity analysis

The author of the work performs a sensitivity analysis using annual forecasted volumes and in the product life-cycle view. During the observation time, the forecasted volumes will be changed by a quarter up (+25%) and a quarter down (-25%) The author is then calculating the total sales revenue, average standard margin, operating income, net present value (NPV), internal rate of return (IRR), investment payback time. The aim of the analysis is to show vulnerability of the project success to external factors that are out of the company's control (such as lower than expected forecast) but also to bring out weaknesses of costing.

2.4 Conclusions

The responses of the conducted survey revealed that the project is mainly assessed by the product profitability and the fit to the existing product portfolio. However, this approach might pose a risk that too much focus is put on the project profitability alone. It could very well be that project is strategically important and the cable manufacturing company will miss out on the opportunity of having its products included in the latest technology released by the ICT customer. This can be avoided through establishing a line of communication with the customer.

To get an idea of the project profitability for the company throughout the life-cycle of the product, the author will be performing series of calculations based on the project profitability model described in the previous subchapter: net present value (NPV), internal rate of return (IRR) and payback time. For all the calculations described above, the author emphasizes that it is essential to keep in mind that the obtained results may not be correspond to reality as, inevitably, animalities might occur throughout the product lifetime. Nevertheless, the obtained results give a real idea of numerical and financial magnitudes.

3 SYNTHESIS AND ANALYSIS

3.1 Product development process analysis

The duration of the product development of the RJ45-RJ45 signal cable assemblies was defined based on the input received from the respondents. As seen from the Table 3.1, calculations based on the timeline show that despite having universal NPD in place, it took the cable manufacturing company 315 days in total to get the product developed and approved which far exceeds the usual development time of 3-6 months not to mention the customer requirements which is 8 weeks.

Table 3.1 Project timeline overview

Event	Date	Number of days passed from receiving the RFQ
RFQ sent by customer	March 21 st , 2019	-
Product specifications sent by customer	April 26 th , 2019	36
Opportunity picked up by PM	May 5 th , 2019	45
Quotes sent to customer	June 4 th , 2019	75
First batch of samples sent to customer	September 19 th , 2019	182
Second batch of samples sent to customer	January 14 th , 2020	299
Customer approval	January 30 th , 2020	315

The main reasons contributing to the long development time were communicated to be the following:

- specific customer requirements on the cable assemblies;
- current raw cable supplier base that does not offer certified material (which is evident based on the dates when the samples were shipped out);
- misleading information received from the customer on suppliers that have certified raw material available.

In addition, the author would also like to point out that to add that it took 36 days for the customer to provide product specifications which makes up more than 50% of the 8-week customer requirement.

3.2 Project profitability calculations

The profit and loss calculations are mostly based on the information received from the respondents of the survey, but some are also found from other sources. The numerical

values during the base year (2020) are the following in order to produce the forecasted amount of cable assemblies:

- 1) total estimated product development cost – 70 000 + 40 000 USD;
- 2) material cost per cable assembly – 3.09 USD;
- 3) labour cost per cable assembly– 0.93 USD;
- 4) engineering cost per cable assembly – 0.40 USD;
- 5) overhead per cable assembly – 0.78 USD;
- 6) freight and duty cost per cable assembly –1 USD;
- 7) quoted unit price to customer, FCA incoterms – 9.61 USD;
- 8) annual price erosion (PE) requested by the ICT company– 8% (author’s estimation);
- 9) annual price erosion (PE) requested by cable company towards its suppliers – 5% (author’s estimation);
- 10)WACC – 8% (Gurufocus);
- 11)average inflation rate forecast of OECD member states – 2.2 % (OECD, 2020).

To calculate the profitability of the project, the author had to first perform the sales revenue calculations which were done based on the forecast, the baseline price and the assumption that the customer wishes to receive an annual price erosion until the end of product life-cycle. The second step was calculating the costs related to manufacturing, distributing the cable assemblies after which were then multiplied with the annual inflation rate published by OECD. While performing the project profitability calculations, the author used the instructions of the project profitability model described in subchapter 2.4. The results of the described calculations are presented in Table 3.1, 3.2, 3.3 and 3.4 where they are presented over of first three years and the entire product lifecycle.

Table 3.2 Projected project revenue and cost

Measurement	Units	3-year view	Product lifecycle view
Forecast	pieces	115 000	210 000
Selling price	\$ / each	8.71	7.97
Total sales	\$	1 001 362	1 674 531
<i>Material cost</i>	\$	247 759	576 577
<i>Labor cost</i>	\$	109 226	204 453
<i>Engineering cost</i>	\$	46 983	87 945
<i>Overhead cost</i>	\$	92 449	173 050
<i>Freight cost</i>	\$	118 082	221 031
Total MFG costs	\$	700 469	1 263 055
Product own cost	\$ / each	6.09	6.01
Standard Margin	\$	300 893	411 475
	%	30%	25%

Despite the 2.2% annual inflation rate costs and an 8% annual price erosion required by the customer, the project is maintaining an average standard margin of 30% during the first three years and 25% throughout the expected product life-cycle. As the cable manufacturing company is required to give an annual PE of 8% towards to the customer, a vital contributor of maintaining high standard margins is the PE received from suppliers of the raw material. Year-over-year calculations are visible in Appendix 3.

After calculating the profitability of the project, the incremental costs such as development costs, product distribution costs, SG&A (selling, general and administrative expenses) of the cable manufacturing company were added to calculate total operating income. The calculations were done by adding operating costs as product development, distribution and are presented below in Table 3.2.

Table 3.3 Calculation of operating income

Measurement	Units	3-year view	Product lifecycle view
Total sales	\$	1 001 362	1 674 531
Total manufacturing costs	\$	700 469	1 263 055
<i>Engineering (design)</i>	\$	70 000	70 000
<i>Distribution and shipping</i>	\$	7 000	14 400
<i>Other</i>	\$	40 000	40 000
<i>SG&A</i>	\$	85 000	131 000
OPEX	\$	202 000	255 400
Operating income	\$	98 893	156 075
	%	9.9%	9.3%

The results reveal that despite having to cover the product development costs amounting to 110 000 USD, the product is maintaining a positive operating income of 9.9% over the duration of first three years of the product life-cycle and 9.3% overall. Yearly operating income calculations for are visible in Appendix 4.

Last of all, the results of the financial metrics calculations are presented in Table 3.4.

Table 3.4 Financial metrics of the project

Measurement	Units	3-year view	Product lifecycle view
Total sales	\$	1 001 362	1 674 531
Operating income	%	9.9%	9.3%
WACC	%	8%	
NPV	\$	6212	100 424
IRR (on NPV)	%	5.0%	38.7%
Average standard margin	%	30.0%	24.6%
Project payback time	years	2.9	

The results reveal that the product is profitable in the presented scenario. Throughout the product life-cycle, the product will remain to have an average standard margin of 24.6%, generate an operating income of 9.3%, have a net profit value (NPV) of 100 424 USD, an IRR of 38.7% and will cover all the related costs in 2.9 years which is less than half of the estimated product life-cycle. The calculations reveal that the IRR is exceeding the WACC value of 8%. However, as the cable assemblies are sold as is optional part of the RRU set-up solution for the telecom companies, then there is a lot of uncertainty involved. The author concludes that aiming for the IRR value to be a higher than WACC might be justified. Nevertheless, it is recommended to check with the customer what their expectations on the volumes are going to be.

3.3 Sensitivity analysis

The sensitivity analysis was performed by increasing and decreasing the total forecasted volumes by 25%. The calculated values are presented in Table 3.5.

Table 3.5 Values of financial metrics after changing the demand forecast

Measurement	Units	Product life-cycle view		
		75% of forecast	100% of forecast	125% of forecast
Total sales revenue	\$	1 255 898	1 674 531	2 093 163
Operating income	%	-20.9%	9.3%	27.5%
NPV	\$	(226 650)	100 424	427 498
IRR (On NPV)	%	0.0%	38.7%	357.7%
Average Standard Margin	%	-0.6%	24.6%	39.7%
Payback	years	-	2.9	1.3

The calculated financial metrics reveal that the project profitability is highly dependent on the amount of sold cable assemblies. For example, the IRR value is 0.0% if the company receives orders in the amount of 75% of the forecasted volumes over the product life-cycle but 357.5% if actual demand is 125% of the initial cumulative forecasted volumes. Furthermore, with the 75% scenario, there is no chance that the project will generate enough profit to cover the investments while the project payback is achieved just after 1.3 years after releasing the product in the optimistic scenario.

3.4 Conclusions and suggestions

To avoid similar situations in the future and improve the product development processes in the cable manufacturing company, the author of proposes the company to consider the following possible solutions:

- adding new suppliers to the existing supplier base that already have their raw cable (UL and CPR) certified: it helps to save 2-3 months of development time, avoids having to pay for the certification separately and the fast delivery of samples might increase the possibility of winning the business opportunity;
- working with the customer with more proactiveness by offering solutions that take less time and resources to develop but still meet the most vital requirements;
- evaluating the possibility of moving the location of product development closer to the customer and/or suitable raw material supplier base which contributes to reduction of the development time by shortening transportation lead times and increased daily communication windows through reduction of time differences.

As the RJ45-RJ45 cable assemblies are sold as optional part of the RRU setup solution to the telecom companies, there is a lot of uncertainty involved regarding the customer demand. Therefore, the author concludes that even though the calculated IRR value is higher than WACC, it might be justified. Nevertheless, it is recommended to check with the customer what their expectations on the volumes are going to be.

The author concludes from the results of the sensitivity analysis that the cable manufacturing company has high fixed costs per each produced cable assembly unit- the higher the total fixed costs, the higher the amount of money the company loses per every cable assembly sold. This gives way to increased risk-taking as the success of the product is highly dependent on the amount of received orders. To reduce the risks but still be competitive with pricing, the author recommends finding a way of optimizing fixed costs, for example by moving the production facility to a new location.

SUMMARY

In this master's thesis, the author collected and analysed data to understand the challenges of developing new signal cable assemblies to an ICT company providing hardware solutions to cellular networks. As an example, a case study describing new product development of two RJ45-RJ45 signal cables by an anonymous cable manufacturing company was used based.

First, the author gathered information on the role of cable assemblies within the architecture of cellular networks, the ICT and cable manufacturing companies, their markets and the theory of new product development applicable to cable assemblies. This was followed by conducting a survey among the employees of the cable manufacturing company to gather information about the case study and internal new product development processes that can be used later in the analysis. Additionally, a profit expectations model was constructed covering the expected lifetime of the product to conduct a financial and sensitivity analysis. Both were based on values of calculated internal rate of return (IRR), net present value (NPV) and product payback time.

As a result of the aforementioned activities, the author came to conclusions that despite the cable manufacturing company having widespread standardized processes in place, it needs to assess its current supplier base alongside with manufacturing footprint to gain agility which plays a key role in winning new business opportunities. Furthermore, based on the results of the financial and sensitivity analysis, the author proposes that to reduce the fixed costs by moving production locations or optimizing cost on headcount to be more price competitive which is vital in a market that is constantly under enormous price pressure.

LIST OF REFERENCES

- Al-Falahy, N., Alani, O. (2017). The Impact of Base Station Antennas Configuration on the Performance of Millimetre Wave 5G Networks. University of Salford, Manchester, United Kingdom; University of Anbar, Iraq. https://www.researchgate.net/publication/318751951_The_impact_of_base_station_antennas_configuration_on_the_performance_of_millimetre_wave_5G_networks/link/5c0ab154a6fdcc494fe1d354/download (06/05/2020)
- Alver, J., Reinberg, L. (2002). Juhtimisarvestus. Tallinn: Deebet.
- Beilmann, M. (2020). K simustiku koostamine. University of Tartu. <http://samm.ut.ee/k%C3%BCsimustiku-koostamine> (22/05/2020)
- Bishop, R. (2017). The World Cable Assembly Market. Bishop & Associates Inc. <https://www.ttieurope.com/content/ttieurope/en/resources/marketeye/categories/connectors/me-bishop-20170512.html> (12/05/2020)
- Boy, L. (2002). Electronics Contract Manufacturing: Global Production and the International Division of Labor in the Age of the Internet, Industry and Innovation, Volume 9, Issue 3, 227-247. DOI: 10.1080/1366271022000034471
- Cable Assembly Market by Application, Product, and Geography - Forecast and Analysis 2020-2024. Infiniti Research Limited. (2020). <https://www.technavio.com/report/cable-assembly-market-size-industry-analysis> (11/05/2020)
- Collins Web Dictionary. <https://www.collinsdictionary.com/dictionary/english/new-product-development> (12/05/2020)
- Corporate Finance Institute (CFI). Working Capital Formula. <https://corporatefinanceinstitute.com/resources/knowledge/modeling/working-capital-formula/> (24/05/2020)
- Davis, E, A. (2018). Global Production Networks and the Private. Organization of World Trade. Journal of Economic Issues, Volume 52, Number 2, June 2018. DOI:10.1080/00213624.2018.1469865 (07/05/2020)

- EPSNews. (2020). MMI: Top 50 EMS Providers Account for \$351 Billion in Revenue.
<https://epsnews.com/2020/04/01/mmi-top-50-ems-providers-account-for-351-billion-in-revenue/> (10/05/2020)
- Ericsson. (2016). New Baseband and Radio System: New DTN Project.
https://www.academia.edu/28342002/New_baseband_And_radio_system
 (02/05/2020)
- Ericsson. (2019). Ericsson Mobility Report.
<https://www.ericsson.com/4acd7e/assets/local/mobility-report/documents/2019/emr-november-2019.pdf> (26/04/2020)
- Ericsson. (2020). Ericsson Annual Report 2020.
<https://www.ericsson.com/495c1f/assets/local/investors/documents/2019/ericsson-annual-report-2019-en.pdf> (20/04/2020)
- European Commission (EC). (2014). Guide to cost-benefit analysis of investment projects: Economic appraisal tool for cohesion policy for 2014-2020.
http://ec.europa.eu/regional_policy/sources/docgener/studies/pdf/cba_guide.pdf
 (20/05/2020)
- Feijóo, C., Gómez-Barroso, J. L., Ramos, S. (2016). Techno-economic implications of the mass-market uptake of mobile data services: Requirements for next generation mobile networks. *Telematics and informatics*. Volume 33, Issue 2, May 2016, 600-612. Science Direct.
<https://www.sciencedirect.com/science/article/pii/S0736585315001215?via%3Dihub> (26/04/2020)
- Fonseca, M., Gorter, O., Kutcher, E., Nattermann, P., Vanderspar, B. (2019). Telecom operators: Surviving and thriving through the next downturn. McKinsey & Company.
<https://www.mckinsey.com/~media/McKinsey/Industries/Technology%20Media%20and%20Telecommunications/Telecommunications/Our%20Insights/Telecom%20operators%20Surviving%20and%20thriving%20through%20the%20next%20downturn/Telecom-operators-Surviving-and-thriving-through-the-next-downturn.ashx> (24/05/2020)
- Garver, B. (2014). Necessary Skills for Successful New Connector Development. ConnectorSupplier.Com.

<https://www.connectorsupplier.com/necessary-skills-for-successful-new-connector-development/> (15/05/2020)

Ginzburg, J., Sag, I. A. (2000). Interrogative Investigations: The Form, Meaning, and Use of English Interrogatives. Stanford: CSLI Publications.

Gurufocus. Amphenol WACC %.

<https://www.gurufocus.com/term/wacc/NYSE:APH/WACC-/Amphenol>
(21/05/2020)

Helfert, E. A. (2001). Financial Analysis: Tools and Techniques: A Guide for Managers. New York: McGraw-Hill.

Hoy, J. (2015). Forensic Radio Survey Techniques for Cell Site Analysis. West Sussex: John Wiley & Sons, Ltd.

Illinois Institute of Technology (IIT). Job Description Questionnaire.

https://web.iit.edu/sites/web/files/departments/procurement-services/pdfs/tempstaffing_job_desc_quest.pdf (22/05/2020)

International Organization for Standardization (ISO). (2017). ISO/IEC 11801-1:2017.

<https://www.iso.org/obp/ui/#iso:std:iso-iec:11801:-1:ed-1:v1:en>
(22/05/2020)

International Organization for Standardization (ISO). ISO 14000: Environmental management.

<https://www.iso.org/iso-14001-environmental-management.html> (22/05/2020)

International Organization for Standardization (ISO). ISO 9000: Quality management.

<https://www.iso.org/iso-9001-quality-management.html> (22/05/2020)

Jem Electronics Inc. (2018). The Wire Harness Manufacturing Process: Step by Step.

<https://blog.jemelectronics.com/wire-harness-manufacturing-process>
(22/05/2020)

Kahn, K. B. (2005). The PDMA Handbook of New Product Development – Second Edition.

New Jersey: John Wiley & Sons, Inc.

Kalmus, V., Masso, A., Linno, M. (2015). Kvalitatiivne sisuanalüüs. University of Tartu.

<http://samm.ut.ee/kvalitatiivne-sisuanalyys> (12/05/2020)

Lieberman, A., Esgate, P., Farris, P. W., Bendle, N. T., Pfeifer, P. E., Reibstein, D. (2013). *Your Guide to Entertainment Marketing and Performance* (Collection). New Jersey: Pearson Education

Littlefuse. Distributed Base Stations.

https://www.littelfuse.com/~media/electronics_technical/application_notes/dbs/littelfuse_distributed_base_station_application_note.pdf (06/05/2020)

McCarthy, M. O. (2020). Background material for US-China Economic and Security Review Commission - Chinese Government Subsidies to the Optical Network Equipment Industry.

<https://www.uscc.gov/sites/default/files/6.14.12McCarthy.pdf> (01/05/2020)

Meticulous Research (MR). (2020). Top 10 Companies in Cable Assembly Market.

<https://meticulousblog.org/top-10-companies-in-cable-assembly-market/> (12/05/2020)

Miao, G., Zander, J., Sung, K., Ben Slimane, S. (2016). *Fundamentals of Mobile Data Networks*. Cambridge: Cambridge University Press.

EPSNews. (2020). MMI: Top 50 EMS Providers Account for \$351 Billion in Revenue.

<https://epsnews.com/2020/04/01/mmi-top-50-ems-providers-account-for-351-billion-in-revenue/> (10/05/2020)

Nakashima, E. (2019). U.S. pushes hard for a ban on Huawei in Europe, but the firm's 5G prices are nearly irresistible. *The Washington Post*.

https://www.washingtonpost.com/world/national-security/for-huawei-the-5g-play-is-in-europe--and-the-us-is-pushing-hard-for-a-ban-there/2019/05/28/582a8ff6-78d4-11e9-b7ae-390de4259661_story.html (01/05/2020)

Nokia Corporation. (2020). Nokia Annual Report on Form 20-F 2019.

https://www.nokia.com/system/files/2020-03/Nokia%20Form%2020F%202019_0.pdf (20/04/2020)

- Nokia Corporation. Mobile broadband HW.
<https://www.nokia.com/about-us/news/media-library/mobile-broadband-hardware/> (22/05/2020)
- OECD. (2013). The Survey of Adult Skills: Reader's Companion. Paris: OECD. DOI:
<https://doi.org/10.1787/9789264204027-5-en> (22/05/2020)
- OECD. (2020). Inflation forecast (indicator). doi: 10.1787/598f4aa4-en (21/05/2020)
- Õunapuu, L. (2012). Valimid kvantitatiivsetes ja kvalitatiivsetes uurimustes. University of Tartu. <https://dspace.ut.ee/bitstream/handle/10062/27764/index.html> (12/05/2020)
- Pahlavan, K., Krishnamurthy, P. (2013). Principles of wireless access and localization. West Sussex: John Wiley & Sons, Ltd.
- Sanders, G., Ellmann, J. (2018). Use of Incentives in Performance-Based Logistics Contracting. Lanham: Rowman & Littlefield.
- Statista. (2018). Market share of telecom mobile infrastructure companies worldwide from 2017 to 2018. <https://www.statista.com/statistics/526037/global-telecom-equipment-market-share/> (26/04/2020)
- Strömpl, J. (2014). Juhtumiuurimus. University of Tartu.
<http://samm.ut.ee/juhtumiuurimus> (12/05/2020)
- Statista. (2018). Telecommunication operators/companies worldwide by revenue in 2018. <https://www.statista.com/statistics/221382/revenue-of-top-30-global-telecommunication-operators/> (09/05/2020)
- Tufts University. Administrative Compliance Assessment Questionnaire: Internal Control Self-Assessment Questionnaire.
http://sites.tufts.edu/amas/files/2010/10/AdminComplianceJointAssessQuestionnaire_March_09.pdf (22/05/2020)
- Ulrich, K. T., Eppinger, S. D. (2012). Product Design and Development – Fifth Edition. New York: McGraw-Hill.

Virkus, S. (2010). Infokäitumise, info hankimise ja otsingu ning infopädevuse uurimise meetodid. Tallinn University.

<https://www.tlu.ee/~sirvir/Infootsingu%20teooria/Infokaitumise,%20info%20hankimise%20ja%20%20otsingu%20ning%20infopadevuse%20uurimise%20meetodid/index.html> (12/05/2020)

Wadhvani, P., Kasnale S. (2020). Telecom Network Infrastructure Market Size, By Component (Product [Base Stations {Macrocell, Microcell, Picocell, Femtocell}, Infrastructure Components {Routers & Switches, Access Points, Firewalls}], Service [Network Consulting, Integration & Deployment, Support & Maintenance]), By Connectivity Technology (2G, 3G, 4G/LTE, 5G), By End User (Telecom Service Providers, Enterprises), Industry Analysis Report, Regional Outlook, Growth Potential, Competitive Market Share & Forecast, 2020 – 2026. Global Market Insights. <https://www.gminsights.com/pressrelease/telecom-network-infrastructure-market> (26/04/2020).

Zyla, M. L. (2019). Fair Value Measurement: Practical Guidance and Implementation. West Sussex: John Wiley & Sons, Ltd

APPENDICES

Appendix 1 Questionnaire

Dear recipient,

My name is Oliver Parv, a student at Tallinn University of Technology, studying Industrial Engineering and Management. This spring, I am writing my thesis on market introduction of customer specific cable assemblies to a multinational networking and telecommunications company.

The main objective of the thesis is to find out the weak spots of the internal processes of your employer when it comes to introducing a new product to such a customer and to improve them. I will intend to write my thesis as a case study based on a recent business opportunity your employer had with a wireless network industry customer involving two outdoor ruggedized RJ45-RJ45 cable assemblies used with a remote radio unit (RRU).

The following questionnaire consists of **49** different questions distributed in 5 different blocks. Please take your time to objectively and truthfully answer as many of the following questions as you can. The identity of the respondents shall remain anonymous. You are also not expected to name yourself, your employer or reveal any of the classified or otherwise sensitive information that you might possess.

I will be very thankful for your responses!

1. Overall questions - job role and employer

- 1.1. What is the title of your current job position?
- 1.2. Please name some of the main job responsibilities that you have at your current job position.
- 1.3. How many years have you been working at your current employer?
- 1.4. How many years have you been working at your current position?
- 1.5. How many employers does your company have in total?
- 1.6. What type of products is your employer producing? Please name at least 3.
- 1.7. On which product categories is the business unit you are working at specialized in producing? Please name at least 3 product categories.
- 1.8. Please name some of the well-known customers of your business unit.

Appendix 1 Questionnaire

2. Questions about internal new product development

- 2.1. Are you involved in the new product development (NPD) process in your company? If your answer is "YES" then what is your role? If your answer is "NO", then please continue from question block number 3.
- 2.2. Do you think that your role in the new product development (NPD) process has been clearly defined by the processes in place at your company?
- 2.3. Which people do you interact internally with while working on a new product development? What kind of information are you exchanging? How is that information exchanged?
- 2.4. In your experience, how long does it usually take to develop a new cable assembly product?
- 2.5. What are the most common bottlenecks in a new cable assembly development?
- 2.6. In your experience, what are the positive sides of the current new product development (NPD) processes within your company? Please name at least 3 of them.
- 2.7. In your experience, what are the main pain points of the new product development (NPD) process to customers? Please name at least 3 of them.
- 2.8. In your opinion, what could be done to improve the existing processes at your current employer?

3. Questions about setting up a business case for new products. If you are not involved in setting up an internal business case for new products, then please continue from question block 4.

- 3.1. Who is responsible for initiating an internal business case? What kind of information is needed to initiate one? What is done after the business case has been set up?
- 3.2. Who is responsible for approving a business case internally? If a committee or a similar organ is responsible for approving a business case, then who are the people involved?
- 3.3. Are there regular meetings in place for approving business cases?
- 3.4. What kind of information is needed to present a business case? What kind of information are you responsible for providing?
- 3.5. Is there a classification of different business cases? What is used to determine the classification?
- 3.6. In case of multiple business case classifications, how are they handled differently?

Appendix 1 Questionnaire

- 3.7. What are the main requirements to get a business case approved?
- 3.8. What kind of measurements are used to get a business case approved?
4. Questions about interactions with a wireless networks industry customer. If you do not have any interactions with this type of customer, then please continue from question block 5.
- 4.1. How is the information of a new business opportunity usually received?
- 4.2. What are the specific requirements of a wireless networks industry customer in comparison to customers from other industries?
- 4.3. Are the products/solutions required by a wireless networks industry customer mostly standard or unique? How does this affect the new product development process?
- 4.4. How quickly does the customer usually wish to receive samples of the proposed design of your employer?
- 4.5. What is usually required by a wireless network industry customer to finally get a cable assembly approved?
- 4.6. What do you think are your employers' strengths when it comes to doing business with a wireless networks industry customer? Please name at least 3.
- 4.7. What do you think are your employers' weaknesses when it comes to doing business with a wireless networks industry customer? Please name at least 3.
- 4.8. In your opinion, what are the most important aspects in a supplier - customer relationship? Please name at least 3.
- 4.9. How long has been your employer been doing business with **CUSTOMER X**?
- 4.10. What kind of feedback have you received from wireless industry customers on the performance of your employer?
5. Questions concerning a business case about outdoor ruggedized RJ45-RJ45 cable assemblies. If you were not involved in this case, then the questionnaire is over for you.
- 5.1. Please describe some of the customer requirements for these specific products.
- 5.2. What was the intended usage of these cable assemblies by the customer?
- 5.3. How are the two ruggedized outdoor RJ45-RJ45 cable assemblies different from each other?
- 5.4. What was the approximate date when you first got information about this project?
- 5.5. Do you think the input data was enough to start building a business case? If "NO", then please provide what kind of information was missing in your opinion?

Appendix 1 Questionnaire

- 5.6. What was the duration of the project?
- 5.7. What was the approximate date when the business case was approved internally?
- 5.8. What was the approximate date when the first samples of the outdoor ruggedized RJ45-RJ45 cables were ready?
- 5.9. What was the approximate date when the final samples the outdoor ruggedized RJ45-RJ45 cables were ready?
- 5.10. How many batches of samples were shipped in total?
- 5.11. What was the approximate date when the samples were approved by the customer?
- 5.12. What kind of testing was conducted on these CAS?
- 5.13. What do you think were the main internal obstacles in this project that caused it to take more time that initially anticipated? Please name at least 3 of those obstacles.
- 5.14. What do you think were the main external obstacles in this project that caused it to take more time that initially anticipated? Please name at least 3 of those obstacles.
- 5.15. What could have been done differently handling this project?

You have now finished the survey! Thank you for taking your time!

Appendix 2 Technical requirements of RJ45-RJ45 signal cables

Category	Parameter	24 AWG cable	26 AWG cable	Test method standard
Connector A	Shielded 8 pos RJ45 plug	CAT5E or better performance		-
Connector B	Shielded 8 pos RJ45 plug	CAT5E or better performance		-
Cable	Jacket color	Black		-
	Conductor	24 AWG	26 AWG	-
	Inner shield material	Tinned Copper		-
	Outer Shield material	Tinned Copper		-
Dimensions	Length	3m ± 1%		-
	Diameter	7.5 mm ± 0.3 mm	6.8 mm ± 0.2 mm	-
Mechanical	Connecting operations	At least 100 times over 20 years		-
	Bending radius	At least 5x diameter of the cable		IEC61196-1-314
	Tensile force	Min 100 N between cable and connector		EC60512-9
Electrical	Attenuation	Max 2.1 dB/100 m @ 1 MHz Max 6.5 dB/100 m @ 10 MHz Max 9.3 dB/100 m @ 20 MHz Max 17 dB/100 m @ 62.5 MHz Max 22 dB/100 m @ 100 MHz	Max 3.2 dB/100 m @ 1 MHz Max 6.5 dB/100 m @ 4 MHz Max 10 dB/100 m @ 10 MHz Max 13 dB/100 m @ 16 MHz Max 17 dB/100 m @ 31.2 MHz Max 23 dB/100 m @ 62.5 MHz Max 30 dB/100 m @ 100 MHz	IEC61156-1
	Return loss	Min 20+5*log ₁₀ (f/f ₀) dB @ 4-10 MHz Min 25 dB @ 10-20 MHz Min 25-7*log ₁₀ (f/f ₀ *20) dB @ 20-100 MHz	Min 20+5*log ₁₀ (f/f ₀) dB @ 4-10 MHz Min 25 dB @ 10~20 MHz Min 25~7*log ₁₀ (f/f ₀ *20) dB @ 20-100 MHz	IEC61156-1
	NEXT	Min 62-15*log ₁₀ (f/f ₀) dB @ 1-100 MHz		IEC61156-1
	ELFEXT	Min 61-20*log ₁₀ (f/f ₀) dB @ 1-100 MHz		IEC61156-1
	Delay Skew	Max 0.45 ns/m @ 4-100 MHz		IEC61156-1
	Characteristic Impedance	100±5 ohm		IEC61156-1
	DC resistance outer shield	Max 5.7 mohm/m		IEC60189-1
	DC resistance inner shield	Max 30 mohm/m		IEC60189-1
	Mutual capacitance	Max 46 pF/m		IEC60189-1
	Insulation Resistance	Min 5000 Mohm/km		IEC60189-1
	Screening attenuation	Min 40 dB @ 1 MHz; Min 20dB @ 10~100 MHz		IEC61156-1

Appendix 2 Technical requirements of RJ45-RJ45 signal cables

Category	Parameter	24 AWG cable	26 AWG cable	Test method standard
Safety	Operating temperature range (ambient temperature)	-40°C to +85°C	-	
Safety	Transport temperature range (in packed condition)	-40°C to +70°C		-
	Storage temperature range (in packed condition)	-25°C to +55°C		-
	Storage relative humidity (in packed condition)	10~100%		-
	List of banned substances	RoHs directive(2002/95EC)		-
	Fire resistance, cable	UL1685, IEC 61300-3-24 cat.C		-
	Fire resistance, connector	UL94V-1 or better		-
	Halogen free	IEC 60754-2		-
	UV resistance	UL1581		-
	CPR	Dca-S2,d2,a2 according to To EN50575 and EN13501-6		-

Appendix 3 Annual project revenue and cost calculations

PROJECT											
Measurement	Units	2020	2021	2022	2023	2024	2025	2026	2027	3-year sum	Product lifecycle sum
Forecast	pieces	26 000	39 000	50 000	50 000	30 000	10 000	5 000	0	115 000	210 000
Selling Price	\$ / each	9.61	8.84	8.13	7.48	6.88	6.33	5.83	0.00	8.71	7.97
Total Sales	\$	249 860	344 807	406 695	374 160	206 536	63 338	29 135	0	1 001 362	1 674 531
Material cost	\$	80 212	114 302	139 214	132 253	75 384	23 872	11 339	0	247 759	576 577
Labor cost	\$	24 050	36 869	48 307	49 370	30 274	10 313	5 270	0	109 226	204 453
Engineering	\$	10 345	15 859	20 779	21 236	13 022	4 436	2 267	0	46 983	87 945
Overhead	\$	20 356	31 206	40 888	41 787	25 624	8 729	4 461	0	92 449	173 050
Freight	\$	26 000	39 858	52 224	53 373	32 728	11 149	5 697	0	118 082	221 031
Total MFG cost	\$	160 963	238 093	301 412	298 020	177 033	58 500	29 034	0	700 469	1 263 055
Own cost	\$ / each	6.19	6.10	6.03	5.96	5.90	5.85	5.81	0.00	6.09	42
Standard Margin	\$	88 897	106 713	105 283	76 140	29 504	4 838	101	0	300 893	411 475
	%	36%	31%	26%	20%	14%	8%	0%	0%	30%	25%

Appendix 3 Annual project revenue and cost calculations

INCREMENTAL											
Measurement	Units	2020	2021	2022	2023	2024	2025	2026	2027	3-year sum	Product lifecycle sum
Total sales	\$	249 860	344 807	406 695	374 160	206 536	63 338	29 135	0	1 001 362	1 674 531
Total MFG costs	\$	160 963	238 093	301 412	298 020	177 033	58 500	29 034	0	700 469	1 263 055
Own cost	\$ / each	6.19	6.10	6.03	5.96	5.90	5.85	5.81	0.00	6.09	6.01
Engineering (design)	\$	70 000	0	0	0	0	0	0	0	70 000	70 000
Distribution and Shipping	\$	2 000	2 000	3 000	3 000	3 000	1 000	400	0	7 000	14 400
Other	\$	40 000	0	0	0	0	0	0	0	40 000	40 000
SG&A	\$	20 000	30 000	35 000	20 000	20 000	5 000	1 000	0	85 000	131 000
OPEX	\$	132 000	32 000	38 000	23 000	23 000	6 000	1 400	0	202 000	255 400
Operating Income	\$	(43 103)	74 713	67 283	53 14	6 504	(1 162)	(1 299)	0	98 893	156 075
	%	-17.3%	21.7%	16.5%	14.2%	3.1%	-1.8%	-4.5%	0.0%	9.9%	9.3%

Appendix 3 Annual project revenue and cost calculations

WORKING CAPITAL											
Measurement	Units	2020	2021	2022	2023	2024	2025	2026	2027	3-year sum	Product lifecycle sum
Annual Inventory Turns	Turns	4								4	4
Accounts Receivable - Days Outstanding	Days	45								45	45
Accounts Payable - Days Outstanding	Days	45								45	45
Accrued Expenses - Days Outstanding	Days	30								30	30
% Material Manufactured by External Vendors	%	90%								90%	90%
% Non-Material MFG Cost by External Vendors	%	10%								10%	10%
Inventory	\$	40 241	59 523	75 353	74 505	44 258	14 625	7 259	0	175 117	315 764
Accounts Receivable	\$	30 805	42 510	50 141	46 129	25 463	7 809	3 592	0	123 456	206 449
Accounts Payable	\$	16 981	25 166	31 919	31 619	18 817	6 229	3 097	0	74 066	133 829
Accrued Expenses	\$	6 633	10 097	13 142	13 349	8 139	2 758	1 402	0	29 872	55 520
Net Working Capital	\$	47 432	66 771	80 432	75 666	42 766	13 447	6 351	0	194 635	332 865
Change in Working Capital	\$	(47 432)	(19 340)	(13 661)	4 766	32 901	29 319	7 095	6 351	(80 432)	0
Net Cash Flow	\$	(90 535)	55 374	53 622	57 905	39 404	28 157	5 797	6351	18 461	156 075
WACC	%	8.0%								8.0%	8.0%
Net Present Value	\$	(83 828)	47 474	42 567	42 562	26 818	17 744	3 382	3 431	6 212	100 150

Appendix 3 Annual project revenue and cost calculations

FINANCIAL METRICS											
Measurement	Units	2020	2021	2022	2023	2024	2025	2026	2027	3-year sum	Product lifecycle sum
Total sales	\$	249 860	344 807	406 695	374 160	206 536	63 338	29 135	0	1 001 362	1 674 531
Operating income	%	-17.3%	21.7%	16.5%	14.2%	3.1%	-1.8%	-4.5%	0.0%	9.9%	9.3%
NPV	\$	(83 828)	47 474	42 567	42 562	26 818	17 744	3 382	3 431	6 212	100 150
IRR (on NPV)	%	-	-	-	-	-	-	-	-	5.0%	38.7%
Average standard margin	%	35.6%	30.9%	25.9%	20.3%	14.3%	7.6%	0.3%	0.0%	30.0%	24.6%
Payback	Years	1.0	1.0	0.9	-	-	-	-	-	2.9	2.9

