

TALLINNA TEHNIKAÜLIKOOL

INSENERITEADUSKOND

Instituudi nimetus

**KIRJAKASTIDE RÄMPSPOSTI VASTASE
KAITSESÜSTEEMI VÄLJATÖÖTAMINE.**

**THE PRINCIPLE OF CREATION THE ANTI-SPAM DEFENDING
SYSTEM FOR LETTERBOXES**

MAGISTRITÖÖ

Üliõpilane:

/nimi/

Üliõpilaskood

Juhendaja:

/nimi, amet/

Tallinn 20...

AUTORIDEKLARATSIOON

Olen koostanud lõputöö iseseisvalt.

Lõputöö alusel ei ole varem kutse- või teaduskraadi või inseneridiplomit taotletud. Kõik töö koostamisel kasutatud teiste autorite tööd, olulised seisukohad, kirjandusallikatest ja mujalt pärinevad andmed on viidatud.

„.....” 20.....

Autor:

/ allkiri /

Töö vastab bakalaureusetöö/magistritööle esitatud nõuetele

„.....” 20.....

Juhendaja:

/ allkiri /

Kaitsmisele lubatud

„.....”20... .

Kaitsmiskomisjoni esimees

/ nimi ja allkiri /

Content

| | |
|--|----|
| AUTORIDEKLARATSIOON..... | 2 |
| PREFACE | 6 |
| INTRODUCTION..... | 7 |
| 1. THE DESCRIPTION OF THE PROBLEM | 8 |
| 1.1. The problem of paper spam correspondence..... | 8 |
| 1.2 The schedule | 10 |
| 2. THE SOLUTION OF THE PROBLEM | 13 |
| 2.1 The preliminary analysis..... | 13 |
| 2.1.1 Preliminary decisions to solve the problem..... | 13 |
| 2.1.2 The black box..... | 14 |
| 2.1.3 Updated objectives | 15 |
| 2.1.4 The preliminary financial reasonability analysis..... | 15 |
| 2.1.5 The entity–relationship model (ER model)..... | 16 |
| 2.1.6 The functional model..... | 20 |
| 2.2 Conceptions for public and personal mailboxes (the general criteria) | 20 |
| 2.2.1 The general criteria..... | 21 |
| 2.2.2 Requirements for the general criteria | 21 |
| 2.2.3 The preliminary analysis of characteristics (material) | 22 |
| 2.2.4 The preliminary analysis of characteristics (shape) | 23 |
| 2.2.5 Possible costs (price) | 24 |
| 2.2.6 The morphological analysis of the general criteria | 26 |
| 2.2.7 The scoring matrix for the general criteria | 27 |
| 2.2.8 The comparison..... | 30 |
| 2.2.9 The final solution for public and personal mailboxes (the general criteria)..... | 31 |
| 2.3 Conceptions for new public mailboxes (in detail) | 31 |
| 2.3.1 The conception 1 for public mailboxes | 31 |
| 2.3.2 The conception 2 for public mailboxes | 32 |

| | | |
|--------|---|----|
| 2.3.3 | The conception 3 for public mailboxes | 33 |
| 2.3.4 | The conception 4 for public mailboxes | 34 |
| 2.3.5 | The conception 5 for public mailboxes | 35 |
| 2.3.6 | Possible costs (price) | 36 |
| 2.3.7 | The morphological analysis of public mailboxes | 37 |
| 2.3.8 | The scoring matrix of public mailboxes | 38 |
| 2.3.9 | The comparison | 40 |
| 2.3.10 | The final solution for public mailboxes (in detail)..... | 41 |
| 2.4 | Conceptions for new personal mailboxes (in detail)..... | 41 |
| 2.4.1 | The conception 1 for personal mailboxes | 41 |
| 2.4.2 | The conception 2 for personal mailboxes | 42 |
| 2.4.3 | The conception 3 for personal mailboxes | 43 |
| 2.4.4 | The conception 4 for personal mailboxes | 43 |
| 2.4.5 | The conception 5 for personal mailboxes | 44 |
| 2.4.6 | Possible costs (price) | 45 |
| 2.4.7 | The morphological analysis of personal mailboxes..... | 46 |
| 2.4.8 | The scoring matrix of personal mailboxes | 47 |
| 2.4.9 | The comparison | 49 |
| 2.4.10 | The final solution for personal mailboxes (in detail) | 49 |
| 2.5 | Conceptions for the new controlling system | 49 |
| 2.5.1 | The conception 1 for the controlling system | 49 |
| 2.5.2 | The conception 2 for the controlling system | 51 |
| 2.5.3 | The conception 3 for the controlling system | 52 |
| 2.5.4 | The conception 4 for the controlling system | 52 |
| 2.5.5 | The conception 5 for the controlling system | 53 |
| 2.5.6 | The morphological analysis of the controlling system | 54 |
| 2.5.7 | The scoring matrix of the controlling system | 56 |
| 2.5.8 | The comparison | 57 |

| | |
|--|----|
| 2.5.9 The final solution for the controlling system | 58 |
| 2.6 The final solution (summary) | 58 |
| 3. THE APPROACH FOR CREATION OF THE PROTOTYPE | 59 |
| 3.1 The implementation of public mailboxes | 59 |
| 3.1.1 The outer part of public mailboxes | 59 |
| 3.1.2 The internal part of public mailboxes | 62 |
| 3.1.3 The additional equipment | 65 |
| 3.1.4 The interim check | 65 |
| 3.2 The implementation of personal mailboxes | 67 |
| 3.2.1 The outer part of personal mailboxes and the separate cubicle for electronics | 67 |
| 3.2.2 The internal part of personal mailboxes and the separate cubicle for electronics . | 69 |
| 3.2.3 The additional equipment | 70 |
| 3.2.4 The interim check | 70 |
| 3.3 The implementation of the new controlling system | 71 |
| 3.3.1 The "server" | 71 |
| 3.3.2 The updated logical schema | 72 |
| 3.3.3 Additional cases | 76 |
| 3.3.4 Interim check..... | 78 |
| 3.4 The final result of the implementation..... | 79 |
| 4. FUNCTIONAL TESTS OF THE CODE..... | 80 |
| 4.1 The testing process | 80 |
| 4.2 The evaluation and plans..... | 83 |
| SUMMARY..... | 84 |
| LIST OF REFERENCES | 85 |
| L1. Laws, surveys. | 85 |
| L2. The equipment. | 85 |
| L3. Other. | 87 |
| L4. List of images and tables. | 87 |

PREFACE

The thesis topic of a project was initiated by the author himself.

The main thesis of the magister project is to show the principle of creation the anti-spam defending system for letterboxes (further "personal mailboxes"). This is only the preliminary approach¹ to the creation of "smart", validating mailboxes.

The meaning "spam" ("spamming") is commonly used for multiple unexpected and not desirable mail (not only email), junk with advertising, leaflets, fraud, political or religious purposes (proselytism), booklets etc.

The anti-spam defending system for personal mailboxes will help to rationalize the receiving process of paper correspondence, to eliminate or **significantly decrease** the amount of spam correspondence.

The thesis of the project involves "Product Development and Production Engineering" course.

¹ This project is the first step to show main principles. Further analyses must be more deepen. So the phrase "to create the anti-spam defending system" means the preliminary approach to the final solution.

INTRODUCTION

Postal activities are tightly integrated with our life. Even in "the Internet Era" with e-mails and messengers, people though need to use physical mailboxes to send or receive paper letters, journals, newspapers, bills, small parcels, and another important paper correspondence. In contrast to the non-paper correspondence, where each customer can adjust privacy settings and minimize spam, physical personal mailboxes are not defended from it. Undoubtedly, there are special anti-vandal mailboxes which have locks with personal keys, combination locks with limited access and permissions, but however they all have one substantial lack - postmen who deliver correspondence must have these private keys and unlimited permissions for personal mailboxes. There is no defense against unfair or weary postmen, who can use the access to put spam inside mailboxes or just forget to close them. So, the effective defense against spam must eliminate the human's factor. The main thesis (goal) of the project is the creation of the anti-spam defending system for personal mailboxes. So, the purpose is to defend personal mailboxes from spam correspondence or at least maximally decrease this kind of correspondence, avoiding human's factor. So, preliminary objectives are to update currently existing mailboxes or to create new.

There will be four chapters in this project (which include six system development life cycle stages. These stages "step by step" are: 1) analysis 2) design, 3) testing, 4) implementation, 5) documentation, 6) evaluation.

The first chapter is a general description of the problem. The second chapter – solution (analysis, what shall be done to resolve the problem). The third chapter – implementation of the solution (how the problem shall be resolved) and the creation of the prototype. The fourth chapter – testing of the implemented solution (to understand, will this solution work in practice). At the end of the project, there are appendixes (documentation), where additional diagrams, schemes, codes, and another useful information are presented.

1. THE DESCRIPTION OF THE PROBLEM

At the beginning, the problem of paper spam correspondence in personal mailboxes must be described in more detail. The author tries to find out does the problem relevant and actual or not. Is it even sense to resolve this problem and to start the project? Will this solution affect positively to society or not? If answers will be negative, then there is no point to start the project, because there will be the waste of time and resources.

1.1. The problem of paper spam correspondence

Why spam is undesirable? Why, actually, there must be protection against it?

Firstly, there is always a danger occasionally to throw out useful correspondence together with spam. If the mailbox is pumped up with junk and there is no free place inside it, there is a risk to lose important correspondence. Very important information may be lost without any responsibility from postal agencies. Paper letters (except traceable or registered letters) have no tracking or control system. Sure, there is a possibility to send letters and small parcels digitally from the e-service. For example, "Omniva AS" company (international logistics company that transports goods and information) offers this service. But this solution does not protect personal mailboxes against spam. Also, if mailboxes are constantly full of spam, there is no confidence that even traceable letters and parcels will not be lost. Registered letters are secured themselves, because receivers will get them from postmen and put a signature on the receipt. But, common letters and another useful correspondence are not secured.

The second reason is following - spam may be dangerous from the perspective of financial security of receivers. There are different monetary fraud and scam schemes, phishing and "Nigerian" letters, gifts with hidden priced subscription etc. Statistics (Survey on "scams and fraud experienced by consumers") show the percentage of experience with fraud in the past two years, detailed results (image below). Some of those fraud letters may be delivered by common mail, not only via the internet.

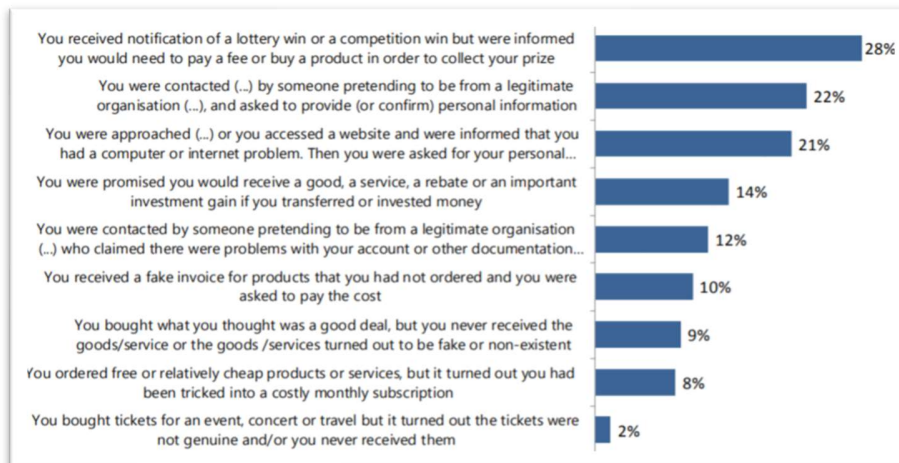

Image 1.1 The survey on "scams and fraud experienced by consumers":

Financial losses due to different fraud schemes are increasing annually². Of course, the main percent of frauds is carried out via the internet (e.g., card ID thefts, remote banking frauds, authorized push payments etc.), but there is a threat to become a victim of fraudsters via the correspondence too.

Also, if mailboxes are mounted in the door (common in private homes) there are risks of burglary, theft of the correspondence. There is a possibility to protect such mailboxes (e.g., using mailboxes nylon bristles, cowls, restrictors etc.), but there is no defense from spam. Sticking out papers, leaflets may be a visual clue to thefts and burglars that no one is home.

The third reason was actual at the last year - the danger of possible COVID-19 proliferation or another (or new) highly spread viral infections. Spam correspondence may be deployed in personal mailboxes by different delivery personnel (not only postmen, but also advertising agents, religious agents etc.), which will increase the movement of people and the likelihood of virus contamination.

Finally, spam correspondence is very annoying. Receivers are wasting their time to draw junk correspondence from personal mailboxes, analyzing the content of it and finally throwing junk out. The current situation with junk correspondence is clearly shown in images below. Personal mailboxes are full of unexpected letters, newspapers, and advertisements. Receivers try to request postmen with special stickers: "Please do not put advertisement without address inside". Those stickers indicate that receivers are bored and annoyed of **overly persistent** spam correspondence.

² Annual fraud report. The definitive overview of payment industry fraud in 2021.

But subjectively, the process of putting correspondence to mailboxes depends on postmen's behavior. There is no trustworthy control over postmen (because of the complexity and congestion of the job, postmen may simply ignore stickers). Therefore, stickers are ineffective.

It again becomes clear, that the problem is actual and needs to be resolved.



Image 1.2. The junk correspondence in personal mailboxes:

Personal undefended mailboxes are full of advertisements. There are special allocated mailboxes for advertisements or special stickers: "Please do not put advertisement without address inside" (in Estonian language "Palume siia aadressita reklaami mitte panna"), but due to the human's factor it's being ignored by correspondence deliverymen.

Also, vandalism acts can be expected. Of course, anti-vandal mailboxes have been already created. Even more, keys for those vandal-resistant mailboxes have only the owner and the postman. So, the spam correspondence cannot theoretically get inside. But the minus of those mailboxes is clear – the postman must have a large "bunch of keys" for each mailbox. In practice, this conception is suitable for small objects.

The author deduces, that the problem of paper spam correspondence in personal mailboxes is actual, relevant, unresolved, and not so harmless as it can seem. The solution of this problem may positively affect the society and there is a direct benefit to correspondence receivers.

1.2 The schedule

For productive and successful job upon the project, the clear plan with time schedule will be done and followed.

The schedule-table will help to keep deadlines in mind and take into account all aspects associated with the project. There are a lot of unaccounted questions and refinements, which will be seen only in process. So, there must be a clear time schedule with a reserve time

capacity. There will be different revisions of the project, and, without schedule, the final revision may contain mistakes or premature data.

In this project, the "forward planning method" will be used. That means, that there is a firm date of the deadline of the project and an approach to project planning will start with the beginning (step by step).

The Gantt chart is a diagram that illustrates a project schedule with "time anchors" for main steps. Those anchors will help to analyze, does the project process in time or there are any delays.

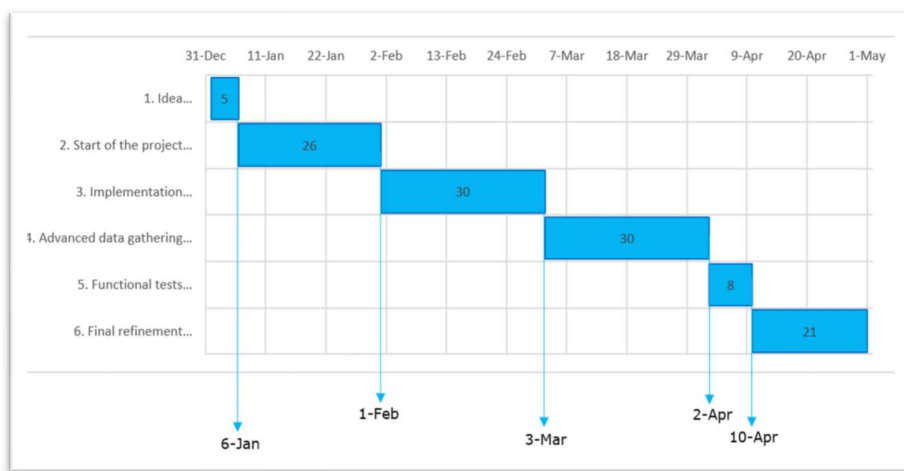

Image 1.3 The Gantt chart with "time anchors" (arrows indicating dates).

Table 1.1 The schedule table:

To plan time for all processes.

| Topics, actions | Start date | End date | Duration (days) |
|--|------------|------------|------------------------|
| 1. Idea, problem research, relevance; preliminary data gathering for mailboxes, for the blocking/controlling system; preliminary financial analysis. | 01.01.2023 | 05.01.2023 | 5 |
| 2. Start of the project; preliminary schemas, conceptions and decision (the final solution). | 06.01.2023 | 31.01.2023 | 26 |
| 3. Implementation. Advanced data gathering for mailboxes. | 01.02.2023 | 02.03.2023 | 30 |
| 4. Advanced data gathering for the blocking/controlling system; possible equipment purchase. | 03.03.2023 | 01.04.2023 | 30 |
| 5. Functional tests. | 02.04.2023 | 09.04.2023 | 8 |
| 6. Final refinement (drawings, appendixes). | 10.04.2023 | 30.04.2023 | 21 |
| | | | 120 days ≈ 17 weeks |

The deadline for the project will be 01.05.2023.

2. THE SOLUTION OF THE PROBLEM

In this chapter, the author will try to solve the problem of paper spam correspondence and to approach to the achievement of the main goal of the project – creation of the anti-spam defending system for personal mailboxes.

2.1 The preliminary analysis

At the beginning, the author has only the basic vision how is it possible to change the situation. Further analyses should be done to deepen the understanding. Preliminary decisions would help to understand the general approach and to "sift all through the mess". Also, the preliminary financial reasonability analysis will be done in this paragraph.

2.1.1 Preliminary decisions to solve the problem

Simplified and preliminary decisions have been made by the "individual brainstorming" (maximum of ideas that are coming to mind in a short period of time - even strange or fantastic proposals).

The first preliminary decision from a set of brainstorming ideas to change the situation is to completely block mailboxes physically. Of course, this decision is inappropriate without elaborative thoughts and clauses, because in this case the main purpose of mailboxes will disappear - the receiver will not get any correspondence at all.

The second preliminary decision is to control postmen and do not allow them to put spam to the personal mailbox. This control must be daily and permanent. Clear that this decision is unachievable for common customers because they have no schedule of postmen's route and even eventual control may be annoying. Video control has no sense too because there is no lawful leverage against unfair deliverymen who are putting spam.

Separately, those two simplified decisions will not work. But together and with clauses there will be another situation. Mailboxes must unite both preliminary decisions with fine-tunes:

1) to block mailboxes physically from unauthorized access, but not completely (to save the main meaning of mailboxes). This is possible to realize with creation of the new **blocking system**. This system may contain additional parts (electronic elements -controllers, scanners or keyboards, locks inside, so the inner shape of mailboxes will be changed, their dimensions may be enlarged etc.), therefore new mailboxes must be created too. Financial costs will

increase, but they will be still lower than for updated "old" mailboxes. In the future there may be possible to update currently existing mailboxes but, in this project, that is advisable not to update old but to create new from the ground up.

2) to allow only expected correspondence. To control the correspondence, but without information about postmen's job schedule and without contact with them (to save social distance). The preliminary solution to control the correspondence needs a creation of the new **controlling system**. The control must be full and will affect all elements of postal delivery. Thus, not only personal mailboxes must be created, but also postboxes (further "public mailboxes"). This controlling system must give the possibility to decide, will the correspondence be allowed or not.

In addition to the second preliminary decision, in the future the author may propose to use own postal service with own postmen, which will help to even strengthen control. Thus, theoretically, the new company based on the project results may be created.

2.1.2 The black box

Black box will explain first steps of preliminary analysis in achievement the thesis of the project (creation the new anti-spam defending system for personal mailboxes).

Black box has the following elements: 1) inputs 2) unknown part "black box" with general context 3) output.

The unknown part means, that there is no knowledge about principles, algorithms, and another internal parts of the project. There is only an idea with inputs and a result as the output, with an unknown part between them.

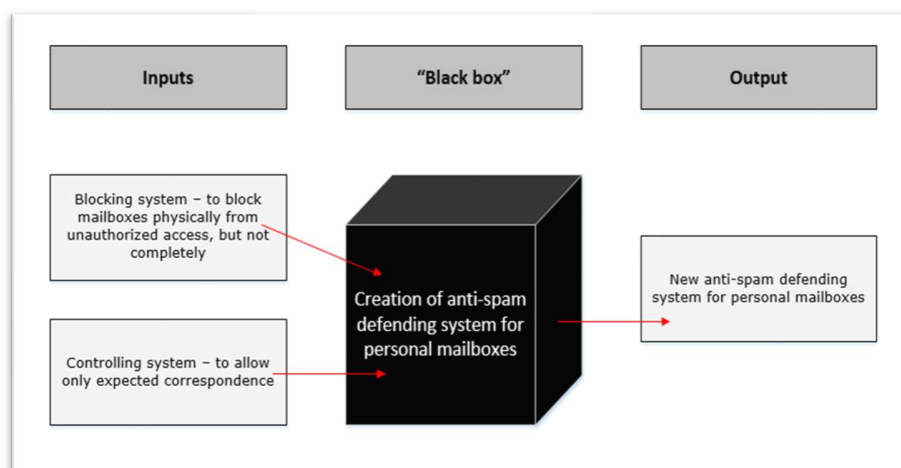

Image 2.1 The black box:

To show the main idea with inputs and desired output.

2.1.3 Updated objectives

Based on two preliminary decisions and "black box" described in chapters upon, the updated objectives for resolving the problem of paper spam correspondence in personal mailboxes will be:

1) to create new public and personal mailboxes with the blocking system. These mailboxes with the blocking system will have additional equipment and block mailboxes from unauthorized intrusion.

2) to create new processes and algorithms of sending-receiving the correspondence with the new controlling system. Those processes and algorithms will give the control over the personal mailbox to its owner. Only the owner of the personal mailbox can decide what to do with the correspondence. So, only **approved by** final customer (the **receiver**) correspondence will arrive to the personal mailbox. Also, in the future the new controlling system may provide an opportunity for tracking the correspondence.

These updated objectives would help companies and, in the future, also common customers not to get any uninvited correspondence to their personal mailboxes. Customers will not contact postmen but will indirectly control their job.

2.1.4 The preliminary financial reasonability analysis

The preliminary financial reasonableness will be done in this paragraph to show, that the successful project may be used for the new imaginary company foundation.

As mentioned earlier, at the first sight there is reasonable to create new mailboxes for companies and people who want to control their correspondence themselves. Of course, the new or modernized mailbox will be more expensive for customers than a common one, but the author believes that new buyers however will come. Little survey has been conducted to understand, will people buy new services in the future or not. There have been 10 people from different gender and age interviewed. Some of those people were owners of their own business, so questions were directed to them, as to company owners too.

The first question was about the spam. "Is spam (unexpected) correspondence in personal mailboxes annoying for you?" The possible answers were "yes" (if the spam is annoying), "no" (if the spam is not annoying) and "maybe" (if sometimes it is annoying, but sometimes it is not).

The second question was about the wish to buy new mailboxes and services. "Will you buy new personal mailboxes which will protect you from unexpected correspondence, even if they will be more expensive than common ones? " The possible answers were "yes", "no" and "maybe".

Each answer has given one point to the scoring table (image below):







| Nº | Gender | Age | Is spam annoying for you? | | | Will you buy new mailboxes? | | |
|-------|--------|-----|--|--|--|--|--|--|
| | | | yes | no | maybe | yes | no | maybe |
| 1 | female | 67 | 0 | 0 | 1 | 0 | 1 | 0 |
| 2 | female | 42 | 0 | 1 | 0 | 1 | 0 | 0 |
| 3 | female | 35 | 1 | 0 | 0 | 0 | 0 | 1 |
| 4 | female | 24 | 1 | 0 | 0 | 0 | 0 | 1 |
| 5 | female | 19 | 1 | 0 | 0 | 1 | 0 | 0 |
| 6 | male | 59 | 0 | 0 | 1 | 0 | 0 | 1 |
| 7 | male | 20 | 1 | 0 | 0 | 1 | 0 | 0 |
| 8 | male | 34 | 1 | 0 | 0 | 1 | 0 | 0 |
| 9 | male | 41 | 1 | 0 | 0 | 0 | 0 | 1 |
| 10 | male | 18 | 1 | 0 | 0 | 1 | 0 | 0 |
| total | | |  7 |  1 |  2 |  5 |  1 |  4 |

Image 2.2 The scoring table for the preliminary financial reasonability analysis survey: To show scores for answers from people of different gender and age.

This preliminary financial reasonability analyses have shown that theoretically there may be new customers to buy new mailboxes with high likelihood and with proper equipment and detailed financial analyses that is possible to create a new company.

2.1.5 The entity–relationship model (ER model)

The ER model is used to specify relationships between entities. Usually there are three levels within ER model: the conceptual schema (data model), logical and physical schemas.

1) The conceptual schema will be created to broaden the understanding of updated objectives described in chapters upon. At the preliminary conceptual schema (image below) there are not shown relationships in detail, only the basic understanding of the possible solution and the basic relationship between two main entities - senders and receivers of the correspondence.

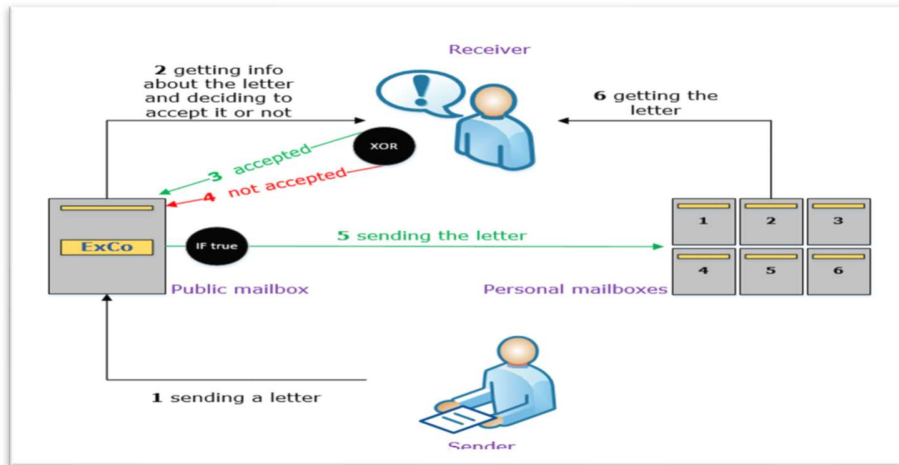

Image 2.3 The preliminary conceptual schema:

To get the basic understanding of the possible solution. The algorithm of actions is numbered from 1 to 6. Only the accepted (3) correspondence is described in this example. Algorithms for not accepted (4) correspondence will be described further.

2) The logical schema will explain the main logical relationship between all participants. The preliminary conceptual schema has shown that there must be extra entities because something must link two main entities (senders and receivers) and their decisions together. So, updated entities will be: 1) senders, 2) receivers, 3) postmen (who will deliver the correspondence), 4) the "server" (will be explained further), 5) public mailboxes and 6) personal mailboxes (mailboxes will have blocking and controlling elements).

Mailboxes cannot send notifications between other entities themselves. Thus, the so-called "server" must be in this project too. The "server" – in the scope of this logical schema is some "unit", some controlling element that will unite and describe all computation processes in the schema, which will help to achieve updated objectives described upon ("...to create new processes and algorithms of sending-receiving the correspondence with the new controlling system..."), e.g., to generate different algorithms, codes which must be unique or to create notifications and communicate with entities. In the future there must be the real controlling element, but in the scope of this project ("...the principle of creation...") functions of the "server" may provide another simplified equipment or programming language (e.g., language C++ variables within code may pretend to be the "server", imitate the functions of the real server).

Also, in the future the new website (or the application) may be created, because all entities must communicate with each other, there must be provided identification of senders and

receivers (the best solution is to use for the identification well-established secure authentication for e-services ID-card, Mobil ID, Smart ID, EU eID). In the scope of this project, functions of the website may provide another equipment or programming language (e.g., variables within code may imitate the registration of new participants which is similar with real registration on the website).

Public and personal mailboxes need to have electronic elements to communicate and operate. For example, scanners, keyboards with monitors, touchscreens may be used for identification of generated codes. Those elements must have their inner controller, which will process in the logical schema too.

At the preliminary logical schema (image below), which is independent of the technology, there are basic logical relationships and algorithms between entities.

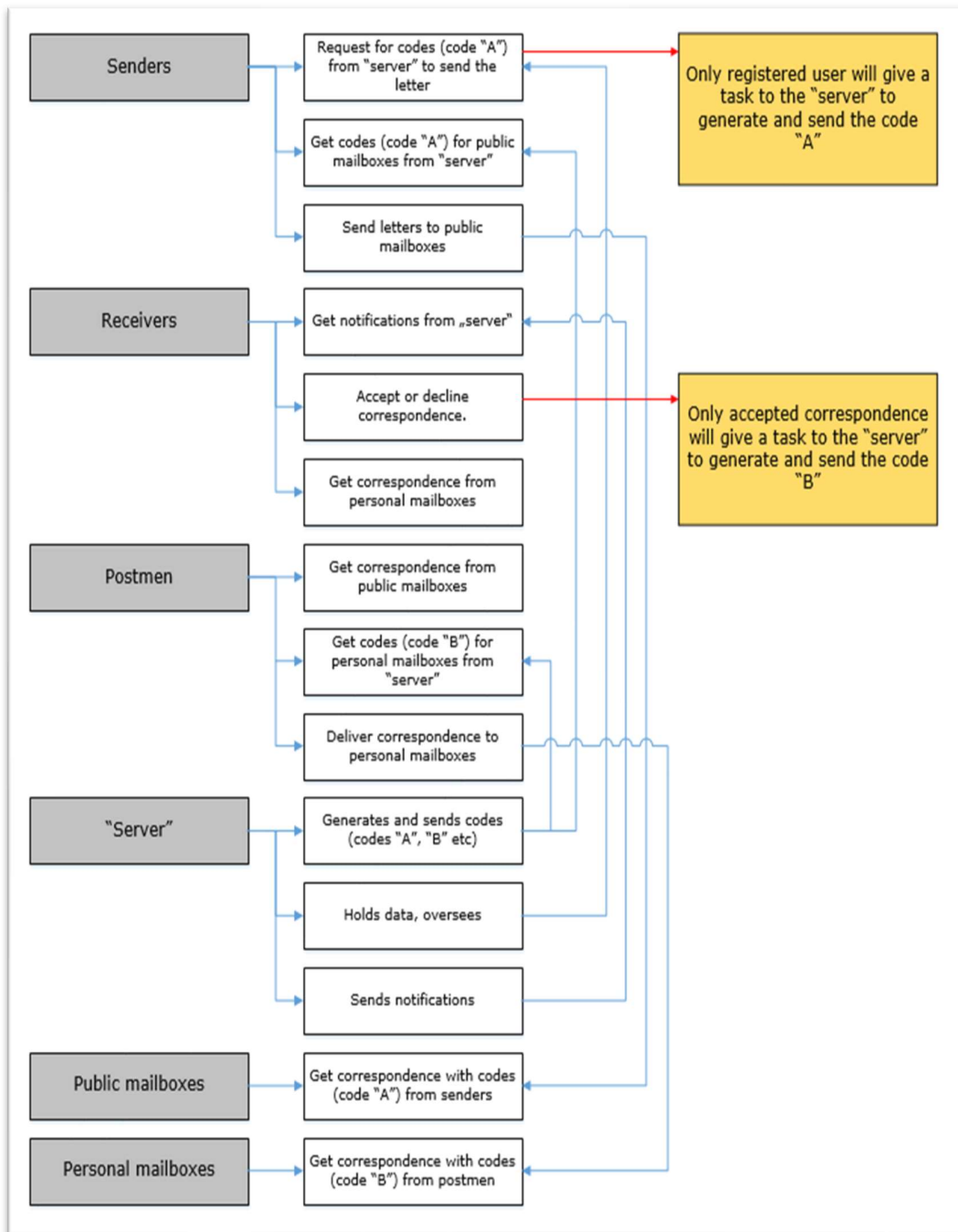

Image 2.4. The preliminary logical schema:

To explain main logical relationships and algorithms between entities. The code "A" will give a possibility to put the letter to the public mailbox. The code "B" will give the possibility to put the letter to the personal mailbox.

3) The physical schema is based on logical schemes. That is complicated, has a lot of data and therefore will not be shown in the scope of this project. But, the imitation of the physical schema will be shown, using the programming language. The physical model must be created in the future in case of the new company foundation.

2.1.6 The functional model

The functional model will be created to give a representation of operations to be done to achieve the main thesis (goal) of the project.

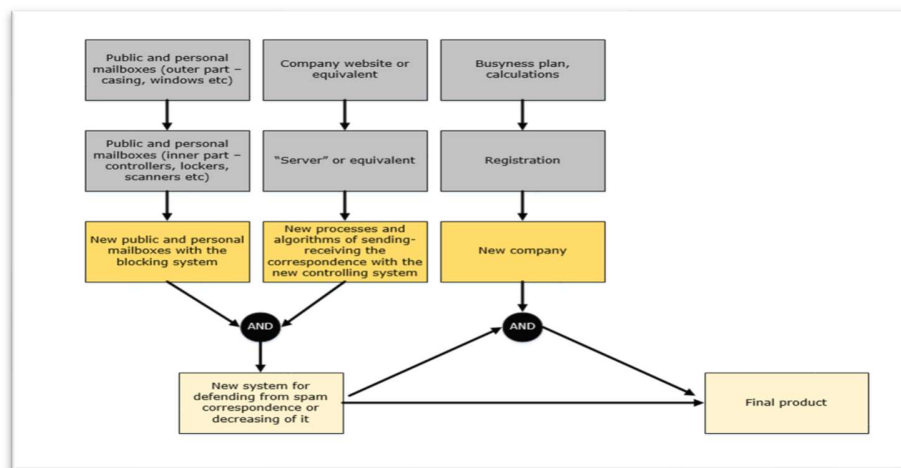

Image 2.5 The functional model:

To give a representation of operations be done to achieve the main thesis.

2.2 Conceptions for public and personal mailboxes (the general criteria)

The core elements of the project are new mailboxes with blocking system. From this paragraph will start the proposing and comparison of different conceptions. Firstly, the general criteria for mailboxes will be described. Then, conceptions for public and personal mailboxes will be reviewed in detail. The last step will be a comparison of the new controlling system conceptions. For each of "comparison paragraphs" in this project following steps will be done: the morphological analysis, the criteria scoring matrix, the comparison of best conceptions.

1) the morphological analysis is used to propose different alternatives for the under reviewed object. It helps to find pluses and minuses within proposed alternatives.

2) the scoring matrix is used to score points from the morphological analysis and to choose the best conceptions. There may be one or more of those best conceptions.

3) the comparison of best conceptions. Best chosen conceptions will be compared with each other. If there is only one best conception, then the second-best conception with fewer scores may be compared too.

After that, the final solution will be chosen. The author must warn, that "final solutions" will only show **the possible** best conception at the beginning of the project. In the future may occur, that there is a problem, which has not been seen, during the theoretical consideration. Therefore, the final solution (so to say "the current decision") may be updated or even totally changed. In this chapter the final solution will be done to move forward to the creation of the real prototype in possible future.

2.2.1 The general criteria

The general criteria for public and personal mailboxes will include two main characteristics – the material and shape. The material may be, for example, non-ferrous metals (e.g., aluminum), different kinds of steels (e.g., galvanized, weathering, stainless), plastic, wood. The shape may be, for example, rectangular, square, round, oval, honeycomb, triangular.

2.2.2 Requirements for the general criteria

Mailboxes must be anti-vandal. The reason to choose anti-vandal mailboxes is clear – vandals, unfair correspondence deliverers and postmen can use physical force to broke mailboxes or their elements. Every mailbox with new blocking conceptions is a reason of indirect loss of profits for those deliverers because they are losing free opportunity to place advertisements. This may cause anger and unprotected mailboxes may be damaged. At the first sight, public mailboxes do not need to have protection against vandals. But looking to the future, there will be wise to „protect weak points“ of the whole system and to create anti-vandal public mailboxes too. Damaged public mailbox may stop the harmonious process of sending the correspondence too.

Also, public mailboxes must have defense from external weather conditions - rain, snow, and dust, because they will be placed outside (IP³ must be at least 45, or even 55). Public mailboxes may be even provided by heating elements because there will be additional

³ IP45. The first numeral characteristic "4" is for protection against solid particles with diameter ≤ 0 mm. The second numeral characteristic "5" is for protection against water jets from any direction.

equipment (electronics) inside and there must be suitable temperature and humidity conditions for it.

2.2.3 The preliminary analysis of characteristics (material)

1) The aluminum (Al) mailboxes are not suitable for anti-vandal purposes. Aluminum is subjected to deformations due to the softness (the hardness of pure aluminum is only 15 HB in Brinell hardness scale). Alloys may have larger hardness (e.g., alloy AW-6060 has already 75 HB, but this is significantly less, than for steels). Aluminum mailboxes are resistant to corrosion. They are very light weighted due to small density (density of aluminum is about 2.71 kg/m³). There is one more minus for aluminum mailboxes. Due to the heat transfer, condensation may form on aluminum surfaces (e.g., aluminum dissipates heat up faster than stainless steel (up to 15 times)). As mentioned earlier, new mailboxes will include additional equipment, which may rise the temperature inside mailboxes and eventually form condensation on surfaces. Aluminum mailboxes are not transparent.

2) The galvanized steel is the steel that have been coated in zinc (Zn), creating alloys, which protect steel from rusting. From the oxidation (the oxygen is one of the reasons of rusting) galvanized steels protect better, than the aluminum. Mailboxes from galvanized steel are durable, sustainable and cost-effective. They are suitable for external conditions very well. But if the "zinc layer" will be damaged, the mailbox will start to rust. This is a minus for the galvanized steel. The alternative may be in using of additional refinements (e.g., painting, doping elements etc.). Mailboxes from steels will be more heavyweight than aluminum mailboxes. Steel mailboxes are not transparent too.

3) The weathering steel (also COR-TEN steel) is a steel alloy with doping components (e.g., aluminum (Al), copper (Cu), chromium (Cr), nickel (Ni), phosphorus (P) etc.). Those doping elements protect steels from the corrosion and give an aesthetically pleasing look for mailboxes (the color palette is rich – from light orange to dark brown tones). Elements must create a patina layer (an oxide coating) which will protect steels from further uncontrolled rusting. This steel is durable and has very strong weatherproof and anti-vandal characteristics. But there are some minuses too. For example, despite strong weatherproof characteristics, the weathering steel cannot be used in extremely dry or humid places (the weather must be changeable). The reason for this is that the amount of protecting patina layer must be permanent, the rusting must be "controllable" (extremely hot or rainy weather changes or reverse the process to uncontrollable rusting). The alternative may be in using special oxide supplements (e.g., act-COR (special oxide activator for weathering steels to start the controllable corrosion), bp-COR (to stop it), bz-COR (to protect additionally from mechanical

damage) etc.). One more problem – weathering steels may "transfer" their controllable rusting to other steels (e.g., joining points, bolts with Zinc (Zn) elements may start the rusting process of them). The alternative may be in using the stainless steel which may contact weathering steels without the above-mentioned problem.

4) The stainless steel is the corrosion resistant alloy with at least 11 percent of chromium (Cr). Also, this steel may contain nickel (Ni), nitrogen (N), manganese (Mn), niobium (Nb) etc. Mailboxes from the stainless steel are rust-free and weatherproof. Stainless steels have good anti-vandal and durability characteristics. Comparing with the galvanized steel (where the "zinc layer" may be damaged), stainless steels have no of this problem. Mailboxes from the stainless steel will have larger weight than aluminum mailboxes, but they also have larger hardness (80 - 600 HB in Brinell hardness scale). Extra pluses of stainless steels are easy maintenance characteristics and low-temperature resistance.

5) Plastic mailboxes must be done from ultraviolet (UV) resistant plastic or with additional refinements (e.g., light absorbing dye, chlorination of PVC, polymer coating etc.) to protect mailboxes from the influence of the sun. Unlike aluminum mailboxes, plastic mailboxes are robust (e.g., absence of dents) and easy to care. Plastic mailboxes are light weighted than mailboxes from another material, may be transparent to show the inner content of the mailbox, but additional refinements (e.g., painting) may offset this plus.

6) Wooden mailboxes are usually not suitable because of the lack of protection from vandals and harsh weather conditions. They are represented in alternatives much for an aesthetic choice, exclusive. Wooden mailboxes are light weighted and not transparent. Such mailboxes may be used in places where other methods of protection are provided.

Short resume: aluminum, wooden and plastic mailboxes are not suitable for anti-vandal purposes. Also, wood is not suitable for external conditions. Galvanized and weathering steels have potential threats of rusting.

2.2.4 The preliminary analysis of characteristics (shape)

1) Rectangular mailboxes have good practicality. They may be installed in different spaces, rooms with different dimensions. Personal mailboxes are usually united in grids. The grid may contain different number of rows or columns and rectangular mailboxes may be elongated (some shapes observed below may be elongated horizontally or vertically too. This is important characteristic for calculations, installations etc.), depending on dimensions of the room and installation requirements. Also, those mailboxes are easy for manufacturing. The design is common, so-called "not interesting", because of the simplicity.

2) Square mailboxes have good practicality characteristics at the first sight. But they cannot be elongated, like rectangular mailboxes. Therefore, minimal dimensions of mailboxes, which will be united in the grid, may not be suitable for some rooms. Square mailboxes are even easier to manufacturing, than rectangular mailboxes, because dimensions are similar. The design is not interesting, because of the simplicity, too.

3) Mailboxes with round or oval shapes for personal mailboxes are not pragmatic. Grids will be massive and have a lot of unused space. Round shapes cannot be elongated too. The alternative for shapes, which have bad practicality characteristics is following – those shapes may be used for public mailboxes, where there is no need of large grids, but interesting design characteristics are important (round or oval mailboxes have interesting design). Also, round or oval shapes are difficult for manufacturing, especially oval shapes.

4) Honeycomb (hexagon) mailboxes have the most interesting design. Also, they have good practicality characteristics. But in a similar way with square mailboxes, they cannot be elongated. Also, those mailboxes are difficult for manufacturing.

5) Triangular shaped mailboxes are additionally pragmatic for personal mailboxes too (they can be elongated, but that will be more difficult in practice, than for rectangular mailboxes). Also, triangular mailboxes are not easy-to-use for additional equipment, electronics which will be installed inside.

Short resume: rectangular mailboxes are suitable, but the design is not interesting. Square, round or oval shapes are not pragmatic for personal mailboxes. Honeycomb shape is interesting for customers, but more complicated to fabricate. Triangular are not easy-to-use for electronics which will be inside.

2.2.5 Possible costs (price)

Independently possible costs (price) as the characteristic will be observed too. As decided earlier, it is advisable not to update old mailboxes but create new. New mailboxes must be anti-vandal (mandatory characteristics for all mailboxes) and weatherproof (mandatory characteristics for public mailboxes). All these characteristics will increase costs.

For the material: the most expensive will be mailboxes from the stainless steel. The cheapest will be plastic mailboxes. According to the analyses made before, only steels meet the requirements of both mandatory characteristics. The galvanized steel price may be 25-40% lower than the stainless steel. The weathering steel is cheaper than the galvanized one.

For the shape: rectangular, square and triangular mailboxes will be cheaper and easier for manufacturing, than others. The most complicated for manufacturing will be honeycomb-shaped, oval and round mailboxes. However, the manufacturing price has the lower priority than anti-vandal and weatherproof characteristics. Therefore, the price characteristic may have not a great value in scoring if mandatory characteristics are not suitable. Also, some other characteristics may have a higher weight than another and that will be considered too.

2.2.6 The morphological analysis of the general criteria

Based on the data described in chapters upon, the morphological analysis of the general criteria will be done.

Table 2.1 The morphological analysis of the general criteria (material):

To show pluses and minuses for each alternative.

| Characteristic | Alternatives | | |
|----------------------------|---------------------|---------------------|---------------------|
| Material | 1) aluminum | 2) galvanized steel | 3) weathering steel |
| anti-vandal, endurance | - | + | + |
| sustainability for weather | + | + | + |
| weight | + | - | - |
| transparency | - | - | - |
| price | + | + | + |
| Material | 4) stainless steel | 5) plastic | 6) wood |
| anti-vandal, endurance | + | - | - |
| sustainability for weather | + | + | - |
| weight | - | + | + |
| transparency | - | + | - |
| price | - | + | + |

Table 2.2 The morphological analysis of the general criteria (shape):
To show pluses and minuses for each alternative.

| Characteristic | Alternatives | | |
|--------------------------|---------------------|---------------|----------------|
| Shape | 1) rectangular | 2) square | 3) round, oval |
| practicality | + | + | - |
| manufacturing simplicity | + | + | - |
| interesting design | - | - | + |
| effective elongation | + | - | - |
| price | + | + | - |
| Shape | 4) honeycomb | 5) triangular | |
| practicality | + | + | |
| manufacturing simplicity | - | - | |
| interesting design | + | + | |
| effective elongation | - | - | |
| price | - | + | |

2.2.7 The scoring matrix for the general criteria

According to morphological analyses, the general criteria matrix will get scores for each alternative (table below). The minimum score is 0 (zero). In this case, the alternative is not suitable at all. The score 1 (one) is for the middle result – the alternative may be available, but not absolute. The score 2 (two) is for suitable alternative, but with additional comments. The maximum score is 3 (three). In this case, the alternative matches perfectly. As mentioned earlier, some characteristics may have a higher weight than another. So, for the material "anti-vandal, endurance" and "sustainability for weather" characteristics scores will multiply by 1 (mandatory characteristics), "weight" – 0.75, "price" – 0.5, "transparency" – 0.25

(insignificant characteristic). Transparency characteristic is interesting, because customers can see the inner part of the mailbox, so they can understand, that there is something inside. But in this project, there is another method of occupancy control (new controlling system). Thus, the transparency characteristic has low weight in the scoring matrix. As a compromise, small transparent material (e.g, from the PMMA glass) observation windows may be used for non-transparent mailboxes. They are suitable for public and personal mailboxes both. They must have small dimensions to meet anti-vandal requirements, too.

For the shape "practicality", "manufacturing simplicity" and "effective elongation" characteristics scores will multiply by 1, "price" – 0.5, "interesting design" – 0.25.

Within rows, "total" there is a sum of all scores in upper columns. The cells with the best scores are highlighted with green color.

Table 2.3 The scoring matrix of the general criteria (material):

To score points from the morphological analysis and to choose best scores.

| Characteristic | Alternatives | | |
|-------------------------------------|--------------------|---------------------|---------------------|
| | 1) aluminum | 2) galvanized steel | 3) weathering steel |
| Material | | | |
| anti-vandal, endurance *1 | 0 | 2 | 3 |
| sustainability for weather *1 | 2 | 2 | 2 |
| weight *0.75 | 2 | 1 | 1 |
| transparency *0.25 | 0 | 0 | 0 |
| price *0.5 | 1 | 1 | 2 |
| total (with a recalculation) | 4 | 5.25 | 6.75 |
| Material | 4) stainless steel | 5) plastic | 6) wood |
| anti-vandal, endurance *1 | 3 | 0 | 0 |
| sustainability for weather *1 | 3 | 2 | 0 |
| weight *0.75 | 1 | 3 | 3 |
| transparency *0.25 | 0 | 3 | 0 |
| price *0.5 | 0 | 3 | 2 |
| total (with a recalculation) | 6.75 | 6.5 | 3.25 |

Table 2.4 The scoring matrix of the general criteria (shape):

To score points from the morphological analysis and to choose best scores.

| Characteristic | Alternatives | | |
|-------------------------------------|----------------|---------------|----------------|
| | 1) rectangular | 2) square | 3) round, oval |
| Shape | 1) rectangular | 2) square | 3) round, oval |
| practicality *1 | 3 | 2 | 0 |
| manufacturing simplicity *1 | 3 | 3 | 1 |
| interesting design *0.25 | 0 | 0 | 2 |
| effective elongation *1 | 3 | 0 | 1 |
| price *0.5 | 2 | 3 | 1 |
| total (with a recalculation) | 10 | 6.5 | 3 |
| Shape | 4) honeycomb | 5) triangular | |
| practicality *1 | 2 | 2 | |
| manufacturing simplicity *1 | 0 | 2 | |
| interesting design *0.25 | 3 | 2 | |
| effective elongation *1 | 0 | 1 | |
| price *0.5 | 0 | 2 | |
| total (with a recalculation) | 2.75 | 6.5 | |

2.2.8 The comparison

On the basis of the general criteria scoring matrix, the best alternatives are mailboxes from stainless or weathering steels with rectangular shape.

Both steels (weathering and stainless) have excellent anti-vandal and weatherproof characteristics. But, as mentioned earlier, the weathering steel has restrictions in extremely dry or humid places (extra supplements must be used). This may increase price. The price of

stainless steels is higher, but in quality-price ratio for the long-term period, the stainless steel will pay itself and will be more profitable. The second reason, why the weathering steel is less preferable even for personal mailboxes (where the weatherproof characteristic is not mandatory), is that theoretically the rust may stain clothes or hands (mailboxes are frequently visited objects). Special coating may protect from this problem, but the price will also increase. Also, weathering steels may "transfer" rusting to other steels. There is no guarantee, that other steels will not be used (e.g., for electronics, locks etc.). So, the best solution will be the stainless steel.

In the future, galvanized steel may be used for personal mailboxes too. This steel has lost one score in the "general criteria scoring matrix" for the sustainability for weather characteristics. But this characteristic is not mandatory for personal mailboxes, which will be installed inside buildings (exception for single personal mailboxes, e.g., for farmhouses).

2.2.9 The final solution for public and personal mailboxes (the general criteria)

The final solution (in the scope of this theoretical part) for public and personal mailboxes (the general criteria) will be rectangular mailboxes from the stainless steel.

2.3 Conceptions for new public mailboxes (in detail)

With clear general criteria possible conceptions for mailboxes may be considered in more details – outer and inner shapes, electronics, other non-essential design details of mailboxes (e.g., plates, signs, handles etc.). Public mailboxes will be installed in a single copy in contrast to personal mailboxes. Thus, all electronic components will be installed inside the public mailbox. Personal mailboxes may have a grid of n-mailboxes and separately installed cubicle for electronics.

For each conception, "pro et contra" characteristics will be observed in short resumes. Main characteristics that will be overviewed are resistance to weather conditions if the receiving window is open⁴, mechanical manufacturing simplicity, electrical installation simplicity, interesting design, size of mailboxes, possible manufacturing cost (price).

2.3.1 The conception 1 for public mailboxes

The first conception is the public mailbox, where the correspondence receiving window will be on the front of the outer casing (image below). The mailbox will have five inner parts

⁴ Endurance for weather conditions for public mailboxes in general has been reviewed in the chapter "2.2 Conceptions for public and personal mailboxes (general criteria)"

(sections). The main part (2) will be for the correspondence. Other parts will be for electronics (scanners, keyboards, locks, wires etc.). The lock for receiving window may be installed in the upper part (1), the scanner - in the bottom part (3), the fourth part (4) may be for controllers or additional equipment and wiring. All parts will have access from outside for maintenance purposes. The extra part (5) will be for wires to unite upper and bottom parts together (1, 3, 4).

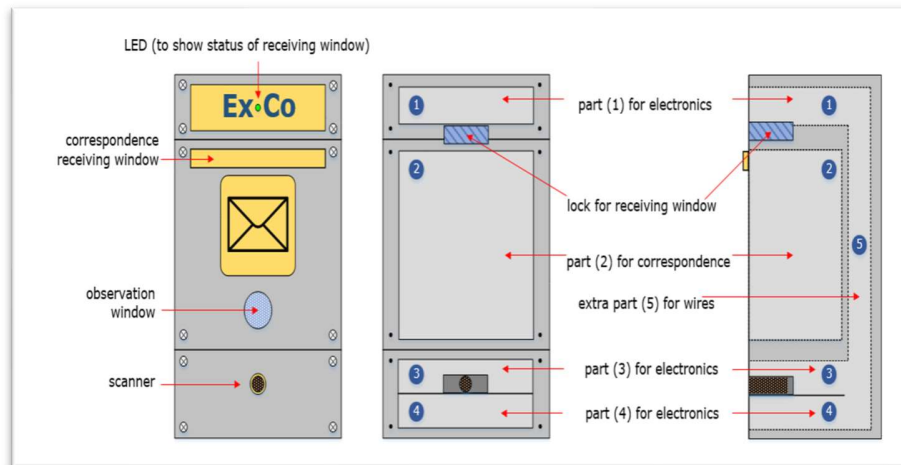

Image 2.6 The conception 1 for public mailboxes:
Front and side view with/without the outer casing.

Short resume: this mailbox will be suitable for harsh weather conditions, relatively difficult for mechanical manufacturing (because there will be complicated extra part (5) for wires) but may offer a potential to make electrical installation simple (because there will be a lot of space for electronics and wires). In the author's subjective view, the observation window may be aesthetically appealing. The size will be relatively large because there are four parts for electronics and wiring.

2.3.2 The conception 2 for public mailboxes

In this conception, the correspondence receiving window will be also on the front. Also, the mailbox will have five inner parts. The difference will be the following: the main part (2) will have a slope to facilitate correspondence falling. Parts for electronics (1, 3) will be larger, than in the first conception. Therefore, the need of extra inner part (5) is not critical, but still may occur the problem of the uniting upper and bottom parts together. As an alternative, the extra part (5) may be narrower than in the first conception. The lock may be installed in the upper

part (1) above the receiving window and the scanner – in the part (3) under the receiving window.

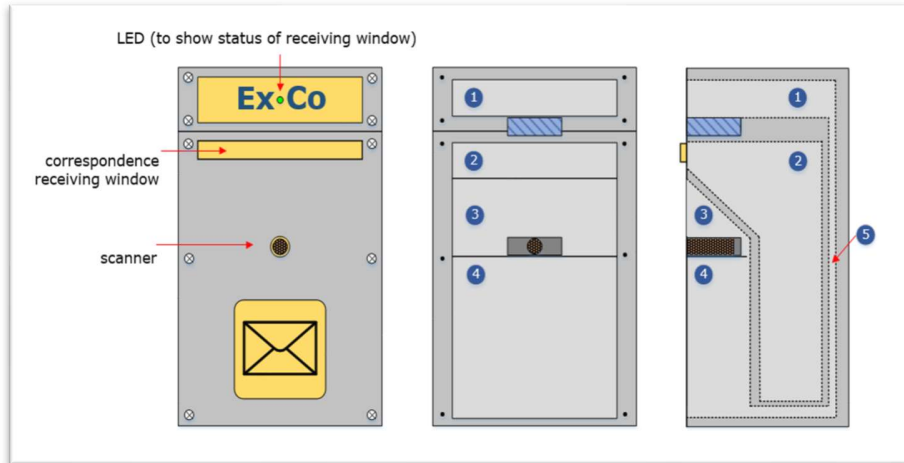

Image 2.7 The conception 2 for public mailboxes:
Front and side view with/without the outer casing.

Short resume: this mailbox will be also suitable for harsh weather conditions, but extremely difficult for mechanical manufacturing (because there will narrow complicated extra part (5) for wires). Electrical installation may become more complicated than in the first conception too, hence the score for electrical installation simplicity will be lowered. The size of such mailboxes will be large. Also, this conception makes it impossible to plant the observation window to the front.

2.3.3 The conception 3 for public mailboxes

The construction will be the same as in the second conception, but the lock and the scanner will be placed in the bottom part (3) together. This will enlarge the main part (2) for correspondence and to unite all electronic devices and wiring together. Therefore, there will be no need of parts (1, 5) for additional equipment and wiring.

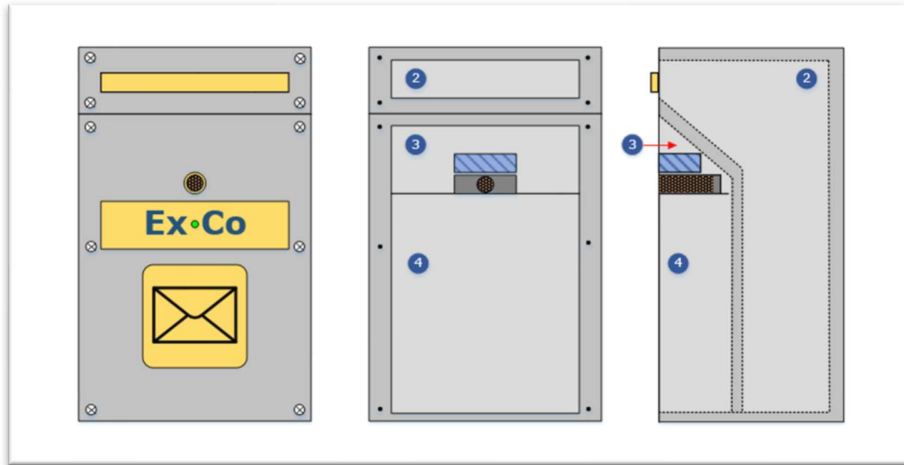

Image 2.8 The conception 3 for public mailboxes:
Front and side view with/without the outer casing.

Short resume: this mailbox will be suitable for harsh weather conditions and for mechanical manufacturing. There will be enough space for electronics and wiring, but problems may arise in practice – the lock installed under the receiving window may hamper the correspondence free-fall. The size of mailboxes will be smaller, because there are only two parts for electronics and wiring. Unfortunately, this conception makes it impossible to plant the observation window to the front.

2.3.4 The conception 4 for public mailboxes

In this conception, the correspondence receiving window will be on the top of the mailbox. Inner parts may be various. Electronics and wiring may be for example installed on the left inner part (1).

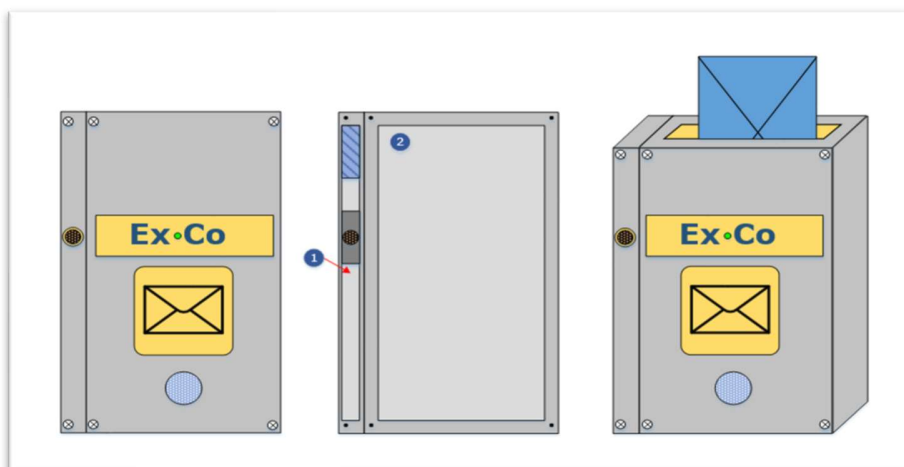

Image 2.9 The conception 4 for public mailboxes:

Front view with/without the outer casing and simplified 3D view.

Short resume: the correspondence will get to the mailbox from the top. Therefore, there will be a high possibility to receive consequences of bad weather conditions (rain, snow, dust). The humidity and mud inside the mailbox are inadmissible – the correspondence and electronics may be damaged. As an alternative, additional protective canopies or overhangs may be used. Mechanical and electrical installation will be simple, but electrical equipment will be squeezed in one narrow part. The size of mailboxes will be small. It is possible to install the observation window too.

2.3.5 The conception 5 for public mailboxes

In this conception the correspondence receiving window will be on the top too, but it will be installed on the slanted plane. So, the upper part (1) for electronics will be smaller. This case would help to enlarge the main part (2) and place the lock higher than, in other conceptions, in the upper plate of the part (1).

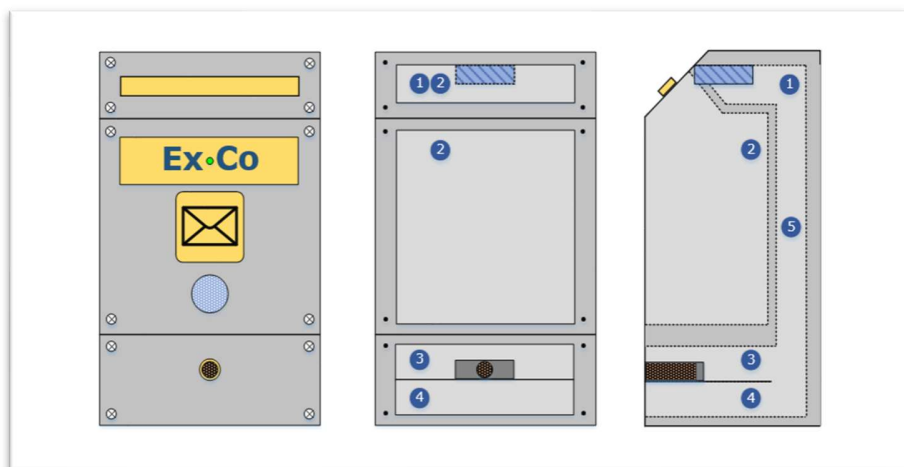

Image 2.10 The conception 5 for public mailboxes:

Front and side view with/without the outer casing.

Short resume: weather resistance for this conception will be low too. Like in the fourth conception, protective canopies or overhangs may be used. Mechanical manufacturing will be relatively difficult but may offer a potential to make electrical installation simple (similar with the first conception). The size of mailboxes will be relatively large. It is possible to install the observation window too.

2.3.6 Possible costs (price)

Independently possible costs (price) as the characteristic will be observed too.

For the first and second conceptions, relatively difficult mechanical installation of the extra part (5) may increase the manufacturing price. The size of mailboxes for the third conception will be smaller. Therefore, the price may be lower than in conceptions 1 and 2. Conceptions number 4 (four) and 5 (five) also may be cheaper, but there may be additional spending of money for protective canopies or overhangs.

2.3.7 The morphological analysis of public mailboxes

Based on short resumes described in chapters upon, the morphological analysis for public mailboxes will be done.

Table 2.5 The morphological analysis of public mailboxes.

| Characteristic | Alternatives | | |
|-------------------------------------|-----------------|-----------------|-----------------|
| | 1) Conception 1 | 2) Conception 2 | 3) Conception 3 |
| weather resistance | + | + | + |
| mechanical manufacturing simplicity | - | - | + |
| electrical manufacturing simplicity | + | - | - |
| interesting design | + | - | - |
| size | - | - | + |
| price | - | - | + |
| Conception | 4) Conception 4 | 5) Conception 5 | |
| weather resistance | - | - | |
| mechanical manufacturing simplicity | + | - | |
| electrical manufacturing simplicity | + | + | |
| interesting design | + | + | |
| size | + | - | |
| price | + | - | |

2.3.8 The scoring matrix of public mailboxes

According to morphological analyses, the public mailboxes scoring matrix may be done. The minimum score is 0 (zero) and the maximum score is 3 (three). As mentioned earlier, some characteristics may have a higher weight than another. So, "weather resistance" and "mechanical manufacturing simplicity" characteristics scores will multiply by 1, "electrical manufacturing simplicity" – 0.75 (because electrical installation may be more flexible even with narrow inner parts), "size" and "price" – 0.5, "interesting design" – 0.25. Within rows, "total" there is a sum of all scores in upper columns. The cells with the best scores are highlighted with green color.

Table 2.6 The scoring matrix of public mailboxes.

| Characteristic | Alternatives | | |
|---|-----------------|-----------------|-----------------|
| | 1) Conception 1 | 2) Conception 2 | 3) Conception 3 |
| weather resistance *1 | 3 | 3 | 3 |
| mechanical manufacturing simplicity *1 | 2 | 0 | 2 |
| electrical manufacturing simplicity *0.75 | 3 | 1 | 2 |
| interesting design *0.25 | 2 | 1 | 1 |
| size *0.5 | 1 | 1 | 2 |
| price *0.5 | 2 | 2 | 2 |
| total (with a recalculation) | 9.25 | 5.5 | 8.75 |
| Conception | 4) Conception 4 | 5) Conception 5 | |
| weather resistance *1 | 1 | 1 | |
| mechanical manufacturing simplicity *1 | 3 | 2 | |
| electrical manufacturing simplicity *0.75 | 2 | 3 | |
| interesting design *0.25 | 2 | 2 | |
| size *0.5 | 3 | 2 | |
| price *0.5 | 2 | 2 | |
| total (with a recalculation) | 8.5 | 7.75 | |

2.3.9 The comparison

Only one conception (conception 1) has got 10 (ten) scores. In second place is the conception 3. The first conception has good weatherproof characteristics. Mechanical installation may be complicated, but there will be enough space for electronics and wiring. The first conception has interesting design with a possibility to install various observation windows, plates etc. The third conception has no possibility to plant the observation window to the front. The manufacturing of the first conception will be easier, due to the lack of slanted planes.

Also, the fourth conception is interesting, but it does not meet the requirement of weather resistance. The fourth conception may be updated (image below). United parts (1, 3, 4) will be on the top, and the main part (2) for correspondence will be on the bottom. In this case, the receiving window will be installed to the front and the mailbox will meet the requirement of weather resistance.

If updates are theoretically possible, then we may consider, that final solutions, which will be made in the chapter "2. THE SOLUTION OF THE PROBLEM" may be updated during the project too. The real creation of the prototype will show possible "weaknesses" of chosen final solutions. Therefore, during the creation of the prototype, the interim check will be provided for all steps.

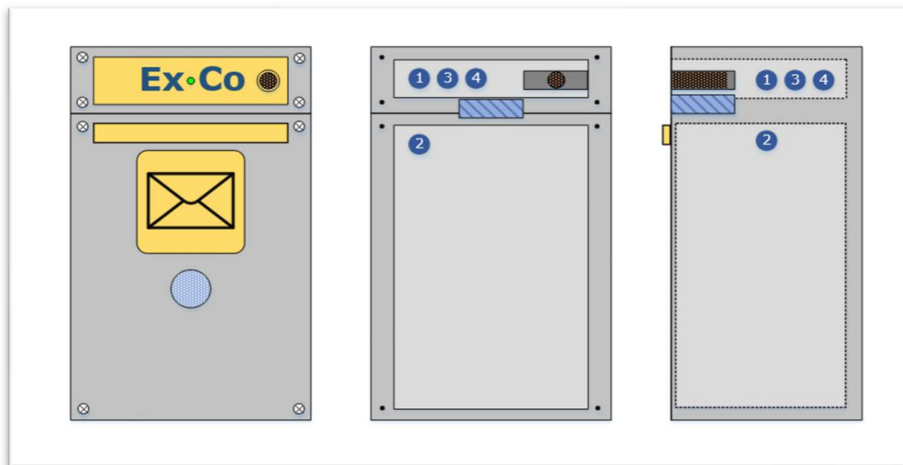

Image 2.11 Updates for the conception 4 for public mailboxes:
Front and side view with/without the outer casing.

Now the first conception will be chosen for this project. It is simple for manufacturing, secured from rainfall and has enough space for electronics. Parts for electronics are large (in the future,

additional elements may be used, e.g., keyboards, touchscreens etc.) and separated. In the future other updated conceptions may be used.

2.3.10 The final solution for public mailboxes (in detail)

The final solution (which may be changed during the project, as mentioned earlier) for public mailboxes (in detail) will be the conception number 1 (public mailboxes, where correspondence receiving window will be on the front of the outer casing).

2.4 Conceptions for new personal mailboxes (in detail)

Conceptions for public mailboxes have been done and conceptions for personal mailboxes will be also considered in more details. As mentioned earlier, personal mailboxes will be installed into grids and the whole system will have a separate cubicle for electronics.

2.4.1 The conception 1 for personal mailboxes

The first conception will be a grid of vertically elongated mailboxes. In contrast with public mailboxes with “monolithic” anti-vandal casing, personal mailboxes will have a door with a handle to retrieve the correspondence from the main part (2) by receivers. This handle may contain the mechanical lock (like in a common mailbox) to open the door. The grid of mailboxes will include a cubicle for electronics with the system of control (e.g., touchscreens, monitors, keyboards, scanners etc.). So, the part (1) for electronics at the personal mailbox may be the only one (compare with the conception 4 for public mailboxes described upon) and even smaller than for public mailboxes. The observation window may be installed differently (in the image below, it will be installed to the upper front plane).

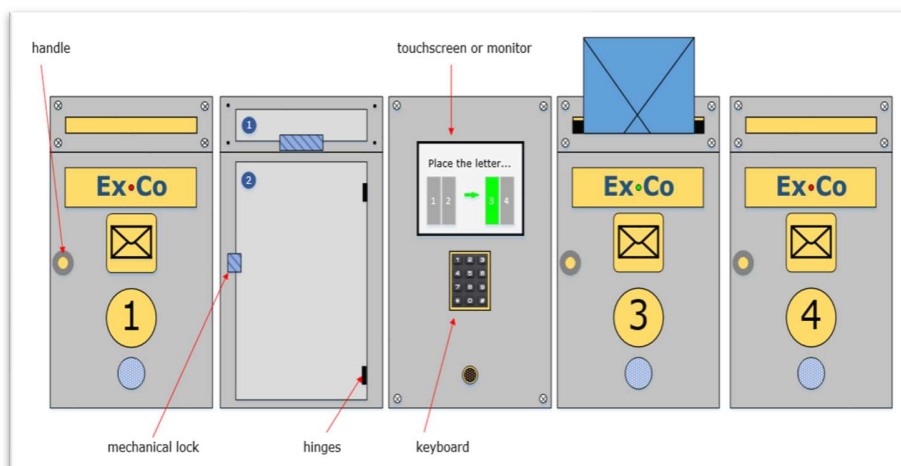

Image 2.12 The conception 1 for personal mailboxes:

Front view with the outer/inner casing and the separate cubicle for electronics.

Short resume: those mailboxes will be simple for mechanical and electrical manufacturing (because there will be only two parts and a lot of space for electronics and wires). The problem for electrical installation may arise in practice (more material for wiring will be used), hence the score for electrical installation simplicity will be lowered. There will be a possibility to install observation windows too. The size of the whole grid (mailboxes and the special cubicle) will be relatively large.

2.4.2 The conception 2 for personal mailboxes

The second conception is a grid of horizontally elongated mailboxes. In contrast with the first conception, mailboxes will be placed horizontally (image below). Also, the update may be done for both conceptions (1 and 2) – may be installed one, overall door to unite the main part (2) and the part for electronics (1) together. This is not a final decision, but only possible variants. Separated plates may facilitate the maintenance, united plates may decrease manufacturing costs.

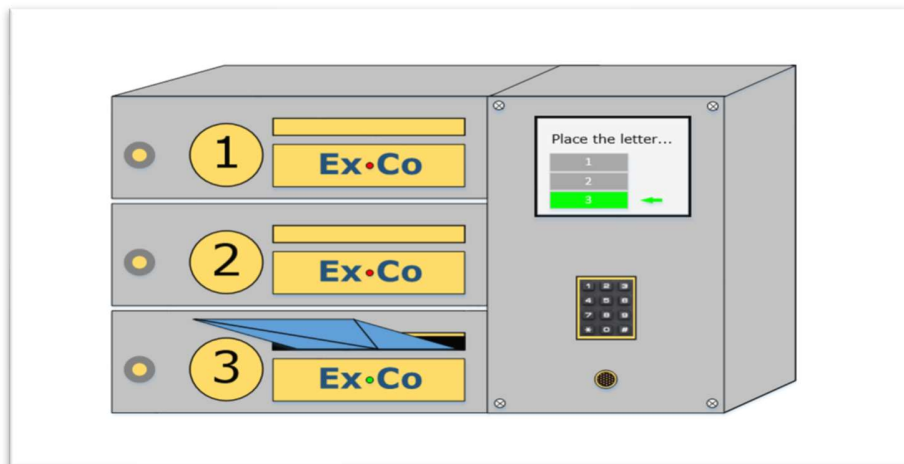

Image 2.13 The conception 2 for personal mailboxes:

Simplified 3D view of the grid of personal mailboxes and the separate cubicle for electronics.

Short resume: those mailboxes are simple for mechanical and electrical manufacturing too. Due to design features (because of the reducing of surface areas), there may be less material for wiring used. There will be limited the possibility to install observation windows because of narrow mailboxes. The size of the whole grid (mailboxes and the special cubicle) will be relatively small.

2.4.3 The conception 3 for personal mailboxes

The third conception will be similar with the second conception. The difference will be only in a slope for personal mailboxes to reduce the size of them even more.

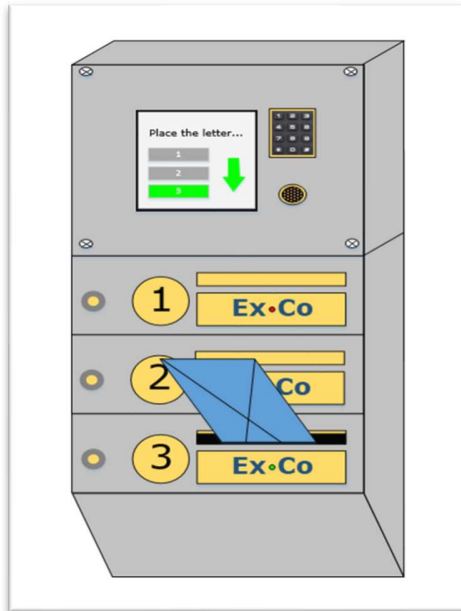

Image 2.14 The conception 3 for personal mailboxes:

Simplified 3D view of the grid of personal mailboxes and the separate cubicle for electronics.

Short resume: those mailboxes will be relatively complicated for mechanical manufacturing and simple for electrical manufacturing. Due to design features, there will be less material for wiring used. There will be limited the possibility to install observation windows too. The size of the whole grid (mailboxes and the special cubicle) will be relatively small.

2.4.4 The conception 4 for personal mailboxes

Mailboxes of the fourth conception will look like a rack for magazines. Vertically placed "columns" of mailboxes will be joined together on stands or pillars.

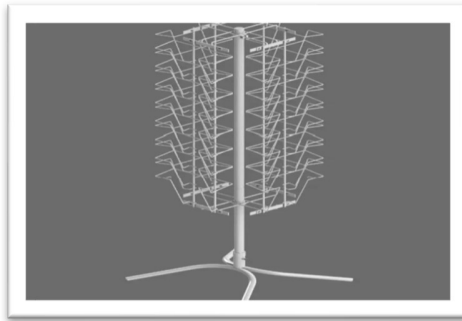

Image 2.15 The conception 4 for personal mailboxes:
Simplified 3D view of the grid of personal mailboxes and the separate cubicle for electronics.

Short resume: those mailboxes will be complicated for mechanical manufacturing and relatively simple for electrical manufacturing. Due to design features, there will be less material for wiring used. There will be the extremely limited possibility or impossible to install observation windows, but the whole design is interesting. As alternative receiving windows, plates may be installed to the side. The size of the whole grid (mailboxes and the special cubicle) will be relatively small.

2.4.5 The conception 5 for personal mailboxes

The fifth conception will totally change the concept of "personal mailbox". There will be only one, overall mailbox (image below) for all receivers (e.g., receivers of multi-apartment building). Since there will be no spam correspondence in personal mailboxes and there will be tracing of the correspondence, the likelihood of "chaos" will be minimized too. For example, one receiver will get a notification about the incoming letter. Other receivers will have no notification, and therefore they will have no need to check the mailbox. Difficulties may arise if a lot of receivers will get letters at the same time (e.g., bills for rent). Also, there will be no defense against unfair receivers, who can steal someone's else correspondence. This conception may be used only for small apartments, offices, or another small places with extremely trusting relationship between receivers.

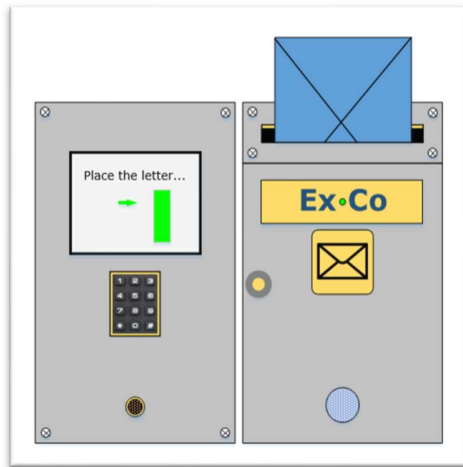

Image 2.16 The conception 5 for personal mailboxes:
Front view with the outer casing and the separate cubicle for electronics.

Those mailboxes will have one more sufficient characteristic, which has not been overviewed in short resumes before – protection. As mentioned earlier, mailboxes may be used for places with trusting relationship between receivers. Thus, short resumes for first four conceptions must be updated with the new characteristic “protection”. Four conceptions above protect receivers; hence, their score in the “personal mailboxes scoring matrix” (will be described later) will be maximum. The fifth conception will have fewer scores for this characteristic.

Short resume: For the fifth conception, mailboxes will be simple for mechanical and electrical manufacturing. There is possible to install the observation window. The size of the whole grid (mailboxes and the special cubicle) will be very small.

2.4.6 Possible costs (price)

Independently possible costs (price) as the characteristic will be observed too.

For the first conception, the size of the whole grid will be relatively large, so costs will increase too. For the second, third and fourth conceptions the size of the whole grid will be relatively small, so costs will decrease too. But for the fourth conception, the price for additional stands or pillars must be considered too. So, the price of mailboxes for the fourth conception will be larger. For the fifth conception, the size and costs of the whole grid will be very low.

2.4.7 The morphological analysis of personal mailboxes

The morphological analysis for all conceptions of personal mailboxes will be done. All characteristic reviewed earlier for public mailboxes will be the same for personal mailboxes.

Table 2.7 The morphological analysis of personal mailboxes.

| Characteristic | Alternatives | | |
|-------------------------------------|-----------------|-----------------|-----------------|
| | 1) Conception 1 | 2) Conception 2 | 3) Conception 3 |
| protection | + | + | + |
| mechanical manufacturing simplicity | + | + | - |
| electrical manufacturing simplicity | + | + | + |
| interesting design | + | - | - |
| size | - | + | + |
| price | - | + | + |
| Conception | 4) Conception 4 | 5) Conception 5 | |
| protection | + | - | |
| mechanical manufacturing simplicity | - | + | |
| electrical manufacturing simplicity | + | + | |
| interesting design | + | + | |
| size | + | + | |
| price | - | + | |

2.4.8 The scoring matrix of personal mailboxes

The scoring matrix for personal mailboxes will be done. The minimum score is 0 (zero) and the maximum score is 3 (three). As mentioned earlier, some characteristics may have a higher weight than another. So, "protection", "mechanical manufacturing simplicity" and "interesting design" characteristics scores will multiply by 1. The design is more important for personal mailboxes than for public. The "electrical manufacturing simplicity" – 0.75, "size" and "price" – 0.5. Within rows, "total" there is a sum of all scores in upper columns. The cells with the best scores are highlighted with green color.

Table 2.8 The scoring matrix of personal mailboxes.

| Characteristic | Alternatives | | |
|---|-----------------|-----------------|-----------------|
| | 1) Conception 1 | 2) Conception 2 | 3) Conception 3 |
| protection *1 | 3 | 3 | 3 |
| mechanical manufacturing simplicity *1 | 2 | 2 | 1 |
| electrical manufacturing simplicity *0.75 | 3 | 2 | 2 |
| interesting design *1 | 2 | 1 | 2 |
| size *0.5 | 1 | 2 | 2 |
| price *0.5 | 1 | 2 | 2 |
| total (with a recalculation) | 10.25 | 9.5 | 9.5 |
| Conception | 4) Conception 4 | 5) Conception 5 | |
| protection *1 | 3 | 0 | |
| mechanical manufacturing simplicity *1 | 1 | 3 | |
| electrical manufacturing simplicity *0.75 | 2 | 3 | |
| interesting design *1 | 3 | 2 | |
| size *0.5 | 2 | 3 | |
| price *0.5 | 1 | 3 | |
| total (with a recalculation) | 10 | 10.25 | |

2.4.9 The comparison

Two conceptions (conceptions 1 and 5) have got maximum points. As mentioned earlier, the fifth conception may be used for small communities with trusting relationship between receivers (the score for "protection" characteristic is low). Therefore, this conception is inappropriate for the project. The second alternative may be the conception 4 with 10 scores. But in the scope of this project this will be more complicated to install mailboxes in a such way.

2.4.10 The final solution for personal mailboxes (in detail)

The final solution for personal mailboxes (in detail) will be the conception number 1 (vertically elongated mailboxes). As mentioned earlier, the conception may be updated or even changed during the creation of the real prototype in the future. All changes in this case will be described within interim checks.

2.5 Conceptions for the new controlling system

The idea to create the new controlling system of receiving the correspondence will be reviewed in this paragraph. There are many possible conceptions for the code reading (e.g., QR-codes or barcodes). Codes must be suitable for all entities - senders, receivers, mailboxes etc. There must be a possibility to send and hold codes. Of course, in the scope of this project only the main idea will be described for possible future updates, but the author will try to broach the subject to make a preliminary analysis for possible future choices, costs, and efforts. In the future, trustworthy code algorithms and cryptography (encryption) may be used.

What would be the core of codes? Will they be digital (e.g., byte, int), graphical (char), symbolic (string, char) or another? Will they be random or constant? The author will try to find different conceptions to answer these questions.

Like for solutions for mailboxes, this chapter will only help to approach to the creation of the real prototype. The reality shows, that customers do not like complicated decisions or make external abusive efforts. Therefore, chosen conceptions may be significantly simplified not only for the future, but for the prototype too. Those chosen conceptions may help in the future.

2.5.1 The conception 1 for the controlling system

The first conception will be to create symbol codes (e.g, digits) which will have a linking part with "static anchors" (sender's or receiver's name, address etc.). Those anchors will help to make a rigid structure of the code. As mentioned earlier ("Image 2.4. The preliminary logical

schema”) senders will get the code (code “A”) only for the public mailbox and postmen will get the code (code “B”) only for personal mailboxes. Also, the code “B” may be available only if receivers will accept the correspondence. This is very important, because, as mentioned earlier, in the future not only personal but public mailboxes must be protected against spam correspondence too. Fully clogged public mailboxes may stop the whole process.

An example to explain the first conception will be shown at the image below. The receiver’s address will be static: Country (a₁, a₂... a_n), County (b₁, b₂... b_n), Street (c₁, c₂... c_n), House (d₁, d₂... d_n), Flat (e₁, e₂... e_n). So, code elements in the database will be linked to that data. The chosen field for the receiver’s address will be highlighted with green color.

| a | Country | Code element | c | Street | Code element | e | Flat | Code element |
|--|---------------|-----------------------|----------------|--------------|------------------------|----------------|------|------------------------|
| a ₁ | Estonia | a ₁ = ES | c ₁ | Viimsi | c ₁ = V2 | e ₁ | 13 | e ₁ = 13F4 |
| a ₂ | Latvia | a ₂ = LA | c ₂ | Vana põik | c ₂ = VP2 | e ₂ | 2A | e ₂ = 2DAF4 |
| a ₃ | Albania | a ₃ = ALB | c ₃ | Vabaduse | c ₃ = VBD2 | e ₃ | 3D | e ₃ = 3DDF4 |
| a ₄ | Algeria | a ₄ = ALG | c ₄ | Vabriku | c ₄ = VBR2 | e ₄ | none | e ₄ = NON4 |
| a ₅ | Great Britain | a ₅ = GB | c ₅ | none | c ₅ = NON2 | | | |
| b | County | | d | House | | | | |
| b ₁ | Harju | b ₁ = HA1 | d ₁ | 18 | d ₁ = 18H3 | | | |
| b ₂ | Ida-Virumaa | b ₂ = IV1 | d ₂ | 6-1 | d ₂ = 6D1H3 | | | |
| b ₃ | Jõgevamaa | b ₃ = JG1 | d ₃ | none | d ₃ = NON3 | | | |
| b ₄ | Järvamaa | b ₄ = JR1 | | | | | | |
| b ₅ | none | b ₅ = NON1 | | | | | | |
| Final code: ES - HA1 - VP2 - 6D1H3 - NON4 | | | | | | | | |

Image 2.17 The conception 1 for the controlling system:

The receiver’s address is country “Estonia” (code element ES), county “Harju” (HA1), street “Vana põik” (VP2), house “6-1” (6D1H3), flat is missing “none” (NON4). The final code will be ES - HA1 - VP2 - 6D1H3 - NON4. Each entity has its own unique code element.

Short resume: Even though each code element will be unique, still this conception will not be unique and may be forecasted. The third part does not need to get special qualification to interfere with the process, so this code will not defend the receiver’s mailbox from unexpected correspondence. For example, the advertisement company may get all code elements to their own database, because code elements will be static (constant) and use them to receive spam correspondence. Thus, this conception must be enforced by an expansion, e.g., the final code will have three random digits at the end (ES - HA1 - VP2 - 6D1H3 - NON4 -**765**). That will be a minus of the conception. The plus of the updated conception will be in the rigid and user-friendly structure. The “user-friendliness” means, that the code is understandable for participants (senders, receivers, postmen). This characteristic is not mandatory and will have

a lower weight. Another characteristic – “problem-free” means, that participants will not get any kind of extra (visible immediately) difficulties in the future. For the first conception, updates must be done, this may cause extra difficulties.

2.5.2 The conception 2 for the controlling system

The second conception will be to use randomly generated codes from the database. This conception will not have “static anchors”, all codes will be randomly chosen from some array (image below). For example, the array with random digits will be created {12;16;76;2;78}. Postmen will get the code “B”⁵ from the array randomly, e.g., the first postman will get the code element 16, the second – 78, the third- 12 etc. Reminder, that the code “B” will be given to the postman only if the receiver has accepted the correspondence.

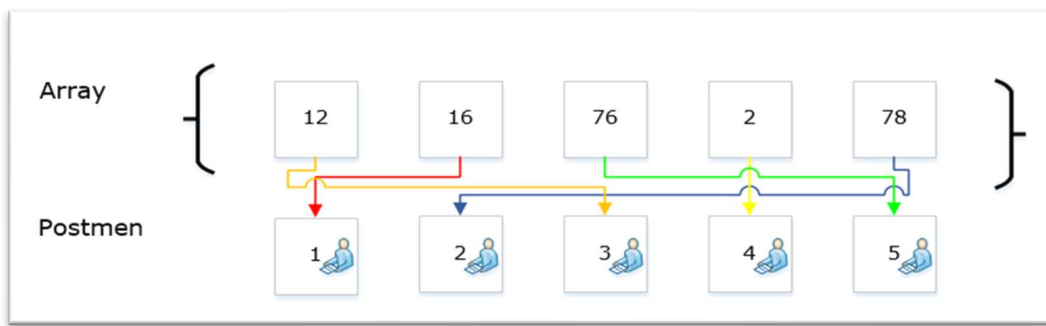

Image 2.18 The conception 2 for the controlling system.

Short resume: At the first sight, high protection will be a plus of this conception (situations with minimal likelihood of the intruding (e.g., “intruder” may guess codes), will not be observed). But there may be one significant “hidden” problem for random codes. As mentioned earlier, personal mailboxes will have the separate cubicle for electronics, so they will be operated by the separate controller (common to all grid of mailboxes). Therefore, the controller must open only one, required mailbox, not random or even all personal mailboxes simultaneously. Otherwise, the protection of the correspondence will be in danger. So, the primary array must be linked with that data. For example, the code element 16, which has been given to the first postman, must be linked with the knowledge of the receiver’s flat number, to open only certain, receiver’s personal mailbox. Also, this conception will be more complex, than the first one. Codes must be linked together and collected to arrays, so

⁵ In conceptions below, only codes “B” will be described. This code plays a major role in protection of personal mailboxes (the main thesis). The principle of other codes is homogeneous.

prescribed algorithms must be created to operate random codes inside the database. The conception is not user-friendly.

2.5.3 The conception 3 for the controlling system

In the third conception, code elements will be random too. The difference between the third and the second conceptions will be following: the first step will be similar (image below) - the array with random digits will be created {12;16;76;2;78}. But the second step will have differences – postmen will get the code in a constant order, not randomly, like in the second conception (e.g., the first postman will get the code element 12, the second – 16, the third - 76 etc.). In other words, the database will have already pre-generated unique codes, which will be distributed to postmen in a strict order. The distributed code may be erased from the database. This may prevent the using of codes twice.

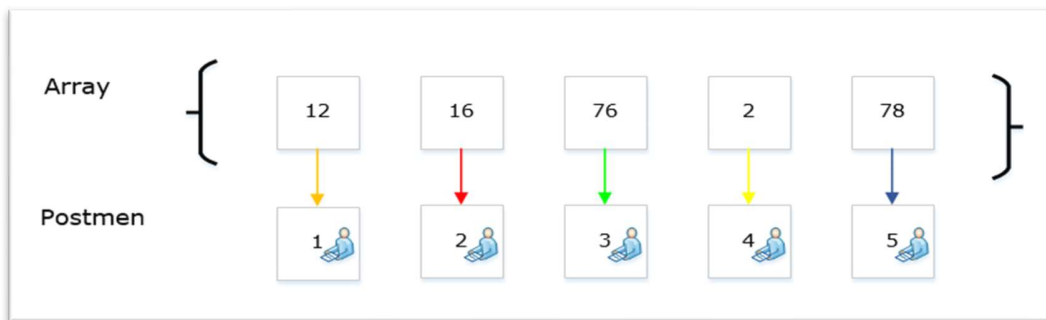

Image 2.19 The conception 3 for the controlling system.

Short resume: This conception will provides protection too, because code elements in arrays will be random and unique (but it is not fully sheltered from the third part infringements, than for the second conception). This conception will be less complex, than the second one, because prescribed algorithms will use consecutive removals of digits from the database, which is simpler, than the random removal (the random choice of codes is more complicated than the constant choice). Like the second conception, the third conception will be not “problem-free”, but it will be more friendly for users.

2.5.4 The conception 4 for the controlling system

In the fourth conception, codes will be generated in the constant order, e.g., from 1 to 5. {1; 2; 3; 4; 5;}, in an arithmetic sequence of natural numbers.

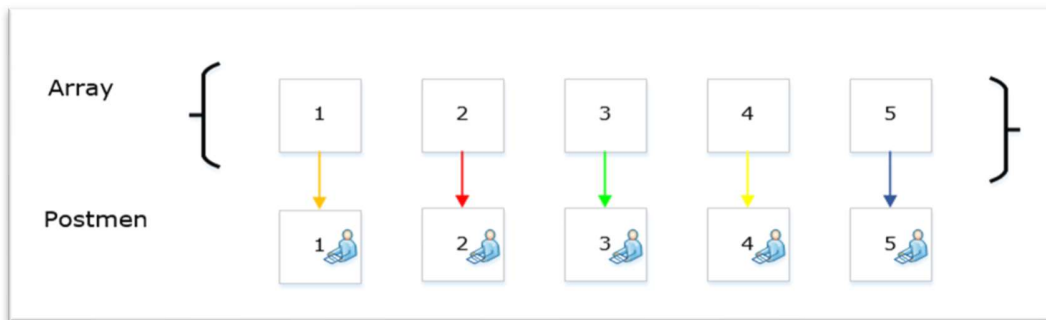

Image 2.20 The conception 4 for the controlling system.

Short resume: At the first sight, this conception will very simple and totally unsecured. However, the protection will be provided. How? Only postmen will know, which code element they have at the moment to open the certain personal mailbox. For example, the first postman will get the code element 1, the next postman will get the code element 2, next - 3 etc. Code elements will be unique, used strictly in order from 1 to ∞ (infinity). Therefore, there will be not possible to get the code element 5, if there were only code elements 1, 2 and 3 before (only 4 will be available in this example). Also, there will not be possible to get code elements 1, 2 or 3 again, so two postmen cannot have the same code. The third part ("intruder") will not have enough information to interfere with the process. There will be no information about the order of code elements in the moment of time (which code element is in action now), so the time factor will play a significant role. There will be no information for "intruders" about the fact and time of postal sending too - only postmen will know about it. If there is no sending activity between main entities at all, then even eventually compromised codes will be useless - the mailbox will stay close. Thus, the third part cannot get an access even with all guessed/cracked code elements and the personal mailbox will be theoretically secured. This conception is simple, user-friendly, but theoretically may have problems in the future, because there are mandatory additional input - time.

2.5.5 The conception 5 for the controlling system

The fifth conception will come from the fourth conception and will be even more simple, than the fourth one. Codes will have no sense at all - they may be random or constant, they may be digital, symbolic, and even not unique. The protection will be ensured, like in the fourth conception, through the acceptance of the correspondence from the receiver. If the receiver does not approve the code, the correspondence will not arrive, and the code structure is not essential at all. Further consideration gives a possibility even to abandon codes for personal

mailboxes. The postman will get the consent of the receiver and open the personal mailbox without any code (image below).

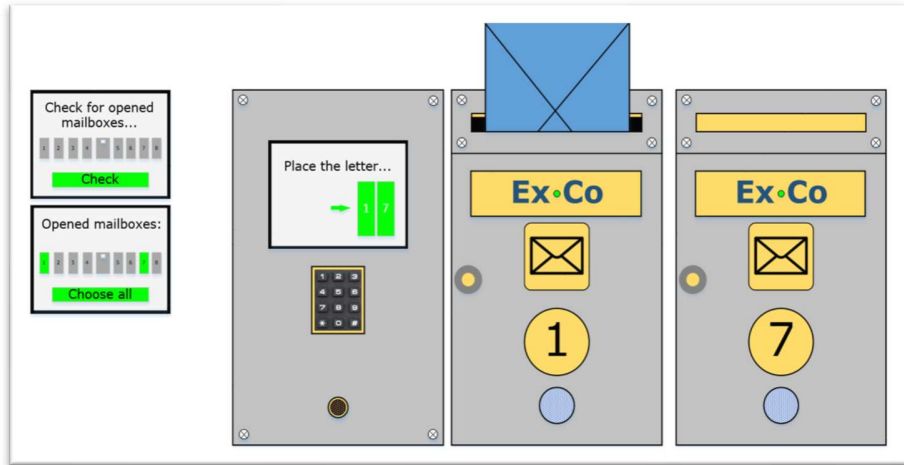

Image 2.21 The conception 5 for the controlling system:

Touchscreen views at the left and front view the grid of personal mailboxes at the right.

Short resume: At the first sight, the minus of this conception is clear. The protection of personal mailboxes may be theoretically reduced if there will be few or many approved accesses. But still there will a decreasing of overly persistent spam correspondence. Those receivers who have not approved the correspondence will keep their mailboxes closed. In other words, postmen will not get any code at all. The code "B" will be implemented to the server, and the postman will only know that the receiver has accepted the correspondence and the address of the receiver. The conception is very simple, user-friendly. Also, this conception will get good scores in "problem-free" characteristic (because there are no visible immediately difficulties in the future).

2.5.6 The morphological analysis of the controlling system

The morphological analysis will include the following characteristics - protection, simplicity user-friendliness and problem-free characteristics.

The protection means, that the main thesis of the project will be achieved - personal mailboxes must be defended and anti-spam defending system for personal mailboxes must be created. This is the mandatory characteristic.

The simplicity means, that the code will not be difficult for implementation. For example, the first conception is not simple. It is user-friendly, but complicated, because of overabundance of heterogeneous variables (digits, letters, symbols).

As mentioned earlier, the user-friendliness means, that the code is easily understandable for participants. This characteristic is not mandatory.

The last one is the "problem-free" characteristic which helps to avoid conceptions with possible, visible immediately problems or difficulties.

Table 2.9 The morphological analysis of the controlling system.

| Characteristic | Alternatives | | |
|-----------------------|---------------------|-----------------|-----------------|
| Conception | 1) Conception 1 | 2) Conception 2 | 3) Conception 3 |
| protection | - | + | + |
| simplicity | - | - | + |
| user-friendliness | + | - | + |
| problem-free | - | - | - |
| Conception | 4) Conception 4 | 5) Conception 5 | |
| protection | - | + | |
| simplicity | + | + | |
| user-friendliness | + | + | |
| problem-free | - | + | |

2.5.7 The scoring matrix of the controlling system

The scoring matrix for the controlling system will be done. The minimum score is 0 (zero) and the maximum score is 3 (three). The "protection" characteristic scores will multiply by 1, "simplicity" and "problem-free" characteristics - 0.75, the "user-friendliness" - 0.5. Within rows, "total" there is a sum of all scores in upper columns. The cells with the best scores are highlighted with green color.

Table 2.10 The scoring matrix of the controlling system.

| Characteristic | Alternatives | | |
|-------------------------------------|-----------------|-----------------|-----------------|
| | 1) Conception 1 | 2) Conception 2 | 3) Conception 3 |
| protection *1 | 1 | 3 | 2 |
| simplicity *0.75 | 1 | 1 | 2 |
| user-friendliness *0.5 | 3 | 0 | 1 |
| problem-free *0.75 | 1 | 2 | 2 |
| total (with a recalculation) | 4 | 5.25 | 5.5 |
| Conception | 4) Conception 4 | 5) Conception 5 | |
| protection *1 | 2 | 2 | |
| simplicity *0.75 | 2 | 3 | |
| user-friendliness *0.5 | 2 | 3 | |
| problem-free *0.75 | 2 | 3 | |
| total (with a recalculation) | 6 | 8 | |

2.5.8 The comparison

Only one conception (the conception 5) has got maximum points. The second alternative may be the conception 3 with 5.5 scores. But in the scope of this project, this will be more complicated to create it. The second reason is that the fifth conception has a huge advantage over other conceptions – the code “B” will be not given to postmen. Therefore, one entity (postmen) will have a lower impact on the process, and that may make algorithms easier. Further, to understand the process better, the code “B” still will be described, but will keep in mind, that in practice it will be taken away from the postman, “missing”.

Since, there is a need to generate codes so-and-so, the third conception (with random code elements placed in a constant order) which has got a lot of scores too will complement the fifth conception.

2.5.9 The final solution for the controlling system

As mentioned earlier, in the future, trustworthy code algorithms will be used. So, the final solution for the controlling system will be chosen only for this project and for the equipment, which will be used for the prototype.

The final solution for the new controlling system may be the conception number 5, where the protection will be ensured, through the acceptance of the correspondence from the receiver and the code "B" will be "missing". This solution will be complemented by the third conception.

2.6 The final solution (summary)

Comparisons have been done above, and final conceptions have been chosen. These final conceptions (in the scope of this project) are:

- 1) The final solution for public and personal mailboxes (general criteria) will be rectangular mailboxes from the stainless steel.
- 2) The final solution for public mailboxes (in detail) will be the conception number 1 (public mailboxes, where correspondence receiving window will be on the front of the outer casing).
- 3) The final solution for personal mailboxes (in detail) will be the conception number 1 (vertically elongated mailboxes).
- 4) The final solution for the new controlling system will be the conception number 5, with the "missing" code "B".

Now, above-mentioned conceptions will be united to the final solution of the whole system. The next chapter will show, how the final solution will be (or can/cannot be) implemented in practice.

3. THE APPROACH FOR CREATION OF THE PROTOTYPE

In this chapter, the final solution will be implemented. The author will make first steps for create the preliminary prototype of mailboxes. All elements (public-, personal mailboxes and the new controlling system) will be reviewed in detail and some of them will be created in practice. Of course, in the future more suitable and expensive devices, materials, software will be used. For example, in the scope of this project the author will not show complete architecture of the planned new system (HTTPS + Json, HTTPS + XML, FTP (integration with outer systems), Rest APIs, APPs, DBMS etc.). This architecture must be used in the future. The preliminary prototype will be created from appropriate inexpensive equivalents. Main purposes of the project are to show the idea and its principles.

3.1 The implementation of public mailboxes

Public mailboxes will have:

- 1) an outer part with casing and casing elements (outer and inner), receiving window, observation window, plates etc.
- 2) an internal part with electronics (controllers, scanners, locks etc.).

3.1.1 The outer part of public mailboxes

The final solution for material and shapes has been chosen earlier. The outer casing of mailboxes will contain partitions, receiving windows, observation windows, fastenings (holes, screws, hinges), different information plates (e.g., company name) etc. Additional final drawings will be shown in "APPENDIXES" too.

1) Casing (dimensions, painting). Outer casings may be manufactured from the stainless steel with different dimensions. For example, public mailbox may have the following characteristics: steel 2 mm (to meet anti-vandal requirements better), height 500 mm, width 300 mm, depth 300 mm. These dimensions are preliminary and may be changed in the process. Also, in the future, other thickness may be used (e.g., steel 3 mm). Elements of the casing may be connected from the inside with welding.

2) Casing plates. Casing plates (e.g., nameplates) from plastic or aluminum will be used only for aesthetic and advertising purposes. The first plate will signify post service (image below).

The second plate will show the imaginary company name "ExCo". External plates may be joined, for example with rivets (using a rivet tool), glue or welding.



Image 3.1 An example of external casing plates.

3) Doors (mechanical locks, hinges). Doors will be used to open and empty public mailboxes from the correspondence. Doors for mailboxes may be done from the same material as the outer casing.

Mechanical locks will be used by postmen and maintenance personnel to open public mailboxes and get the correspondence. For example, they may be fixed transom locks, mechanical code locks, cam locks, cylinder locks etc. Mechanical locks must be vandal resistant and secret, too. For example, the mechanical stainless-steel lock Emka 1000-SU951-RE (image below) with the secret locking system and IP65 may be used. In the future may refuse from the installation of mechanical locks and use only electromagnetic locks both for receiving windows and doors.

Hinges will be used to open doors. Hinges for the door must be hidden (secret) too and installed inside mailboxes. So, internal corner hinges or surface mount hinges, where concealed screws, prevent external access to hinges. For example, the non-visible (hidden) stainless steel Emka 1031-U2 hinge (image below) may be used. Also, concealed spring-loaded hinges may be used to provide tension so that the door will close automatically.

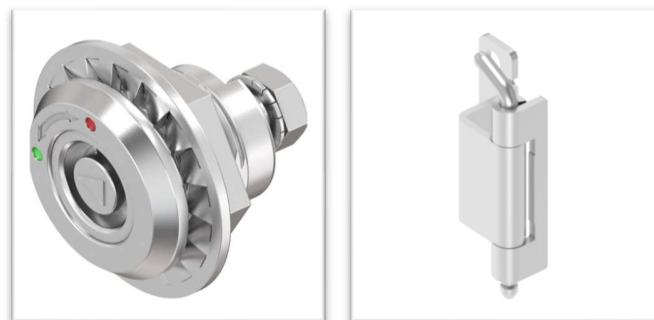

Image 3.2 The lock Emka 1000-SU951-RE, the hinge Emka 1031-U2

4) Observation windows. Decorative observation windows may be manufactured from the PMMA glass or plastic. These transparent windows will help to understand, is there something inside the mailbox. These windows like plates described above (with company name, the number of flat etc.) are not mandatory and are intended only for design purposes. Observation windows must be vandal resistant (the alternative is to use small observation windows).

5) Receiving windows. The size of receiving windows must be suitable for standardized⁶ correspondence. This window may be opened only strictly observing the conditions of the access (electrical locks will be used). For this project, the size of receiving windows may be 235 x 25 mm for providing "C4" (envelopes with dimensions 229 x 324 x 20 mm) and smaller size envelopes to be used.

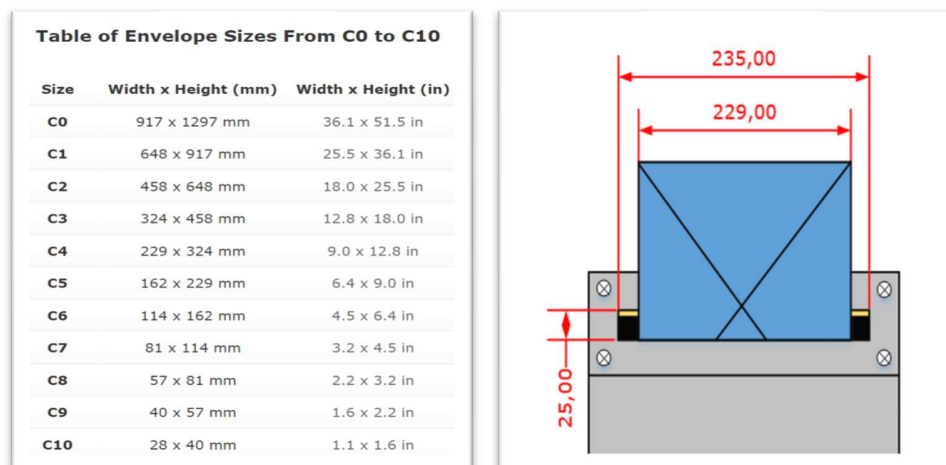

Image 3.3 Standards of envelopes and dimensions of the receiving window.

6) Fastenings (screws, adapters, stands). Fastening will help to attach mailboxes to the wall or pillars. The mailbox may be suspended from the wall, pillars or may have its own adapters, stands.

For the first case, the allowable load must be calculated. The public mailbox (depending on size) may store up to 500 letters. For preliminary calculations, let's assume, that the weight of the full public mailbox (with electronics and filled with the correspondence) will be 30 kg. The equation for mass is:

$$m = \rho * V$$

⁶ The size of envelopes in Europe is standardized. ISO 216 is the standard for paper sizes with ISO 269:1985, which defines the C series for envelopes.

, where m - mass, ρ - density, V - volume.

Stainless steel's density is approximately 8000 kg/m^3 (e.g., SAE 304⁷ stainless steel density is 7930 kg/m^3). The volume of cuboid is:

$$V = a * b * c$$

, where a , b , c - dimensions of the cuboid (length, width, depth).

The volume of public mailbox may be approximately 0.05 m^3 . This volume is for the full cuboid (outer dimensions), but mailboxes are hollow. That means the required volume will be the difference between outer and inner volumes (in the scope of this project 2 mm stainless steel will be used). So, approximately the weight of the empty public mailbox will be 6 kg.

For the second case, the public mailbox will be planted to its own adapters, stands. Those devices may additionally protect public mailboxes from violence, storm etc. too.

For the preliminary prototype, fastenings will not be used. Final drawings for components of the casing will be shown in "APPENDIXES". Also, calculations in "ANSYS" will show possible deformations of the loaded mailbox and will be placed to "APPENDIXES" too.

3.1.2 The internal part of public mailboxes

There will be electronics and wiring inside public mailboxes – controllers, scanners, locks etc.

1) Controllers. The controller will provide all actions with codes, help to open locks, to communicate with scanners, keyboards etc. For example, controller AM8046 with many interfaces (TCP/IP, RS485, 4G, Wi-Fi), up to 984 channels (image below) may be used.

2) Locks for the receiving window. Locks will provide the access control for mailboxes. In normal state, the receiving window will be closed. The closed state will protect the mailbox physically from any unexpected invasion from outside. Locks may be electromagnetic, electromechanical, electronic code locks, electronic deadbolts, key card locks etc. For example, Kenrone electromechanical lock IP65 (image below) may be used. Locks must be vandal and harsh weather resistant.

3) Keyboards may be used to insert codes. For example, Emka 3000-U45-05 IP68 (image below) may be used. In the future another types of keyboards (e.g., touchscreens with virtual

⁷ SAE 304 stainless steel is the mostly used stainless steel. The alloy contains both Chromium (Cr) - 18 - 20% and Nickel (Ni). - 8 - 10.5%.

keyboards, RFID card readers etc.) will be used too to allow read codes and simplify the process. Keyboards must be vandal and harsh weather resistant.

As mentioned earlier, in the future scanners (e.g., for QR-codes) may be used too. Scanners will simplify the process. For example, SSTC-JL-5066 IP66 rated, with a wide temperature range (image below) may be used.

4) Displays. The display will imitate the monitor or touchscreen, that can be used in the future. The main purpose of the display is to communicate with users, to show inserted codes and status. For example, Mimo MOD-10180CH 10.1" outdoor capacitive touch display, IP65 rated, with a wide temperature range (image below) may be used. In the future, another types of monitors or touchscreens may be used. Displays must be vandal and harsh weather resistant too.

5) The power supply. The power supply will be powering the electronics. For example, LRS-100-12 AC/DC power supply, with a universal AC input; an output 12VDC, current 8.5 A (image below) may be used.

For smooth operations, the UPS (uninterruptible power supply) must be used. Power supply (wiring) must meet anti-vandal requirements too. They must be maximally hidden to protect mailboxes from vandalism.

6) Heating elements. Heating is important for public mailboxes due to harsh cold weather. Electronics inside must be secured in winter. For example, Eberle FTR-E 3121 indoor thermostat (image below) with "supported" and proper (IP55) equipment (heating element, junction box etc.) may be used. In the future different types of heating equipment may be used. Therefore, there must be provided free space inside public mailboxes for additional equipment.

7) Wiring, LEDs. Wiring will unite all electronic components together. Multicolored LEDs may be used for information purposes (e.g., the status of the door – opened (red), closed (green) etc.). For example, 0035.0668 Schurter LED green, 24VDC, Ø8.4 mm, IP67(image below) may be used. In the future, different types of cables and another type of LEDs may be used.



Image 3.4 The controller AM8046, the electromechanical lock Kenrone, the keyboard Emka 3000-U45-05, the touch display Mimo MOD-10180CH, the LRS-100 power supply, the Eberle FTR-E 3121 indoor thermostat, the LED 0035.0668 Schurter

3.1.3 The additional equipment

As mentioned earlier, all equipment and software for the project in the future may be changed to more trustworthy, expensive and appropriate equivalent. Also, in the future, different additional equipment may be used to facilitate the usage of mailboxes. The author may propose to use:

- 1) Motion sensors. Motion sensors may be installed inside the mailbox. This equipment will help to understand, that the correspondence has been already thrown to the mailbox and give the feedback to the controller to close the receiving window. This will help to minimize the possibility to put extra correspondence inside.
- 2) Climatic sensors for temperature and humidity measurements. Those sensors may additionally measure ambient humidity and temperature outside/inside the public mailbox.
- 3) Security cameras. Security video cameras will provide the defense against vandals.
- 4) Printers. The built-in printer inside the public mailbox will give a possibility to print generated codes on the adhesive paper.
- 5) Additional audio speakers for prompts, clues.
- 6) Scales for weighting to send notifications to the postal company, if the public mailbox is fully clogged and need the maintenance.

3.1.4 The interim check

As mentioned earlier, the interim check will help to understand, which updates must be done after the implementation. Some problems become clear only in the process. Therefore, the interim checks with schedule check must be provided.

The first update for the public mailbox must be done for the receiving window. As mentioned earlier, in normal state, the receiving window will be closed (image below). To ensure the forced pressing of the receiving window to the casing, mechanical compression springs may be used. Those springs must allow putting the correspondence without big efforts but must facilitate the forced closing of the receiving window too. Firstly, the plate of the receiving window must be under the pressure in relation to the outer casing. Described upon, springs will provide it. Secondly, the plate in the closed position must be blocked from opening by the electromechanical lock. And finally, the plate in the opened position must provide the possibility to put the correspondence inside the mailbox. All elements (springs, the plate, the electromechanical lock etc.) must be fixed on the outer casing. The chosen solution for public mailboxes does not describe these changes accurately. So, the final conception for public

mailboxes chosen before (within the theoretical analyses) **is not suitable and must be updated**. Also, updates must (if possible) meet all requirements for the chosen solution (according to the scoring matrix described earlier).

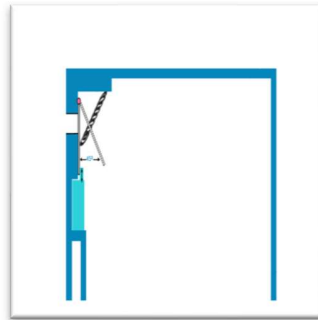

Image 3.5 The preliminary vision of possible installation of the receiving window with the electronic lock.

The second update must be done for inner parts of the casing. The creating of the preliminary prototype in "ANSYS" and practical installation of some parts have shown that there are too many free spaces for electronics and wiring, excessive. There is no need for four separate parts (sections). This will reduce size and price of the public mailbox and there must stay simple for the mechanical and electrical manufacturing. Also, updates will be done for holes for wirings.

The schedule has been revised too. There is no need to make changes or updates there because updates have been made without getting out of the schedule (no extra time is needed).



Image 3.6 The vision of the updated public mailbox.

After all updates, the first step for the implementation of the preliminary prototype for public mailboxes has been finished, some components have been physically installed and the preliminary vision of electronic connections has been made.

The next step is the implementation of personal mailboxes.

3.2 The implementation of personal mailboxes

Personal mailboxes will have:

- 1) an outer part with casing, receiving window, observation window, plates etc.
- 2) an internal part with electronics (controllers, scanners, locks) and internal elements of casing.

The separate cubicle for electronics will also have an outer and internal parts.

3.2.1 The outer part of personal mailboxes and the separate cubicle for electronics

The final solution for material and shapes has been chosen earlier. The outer casing of personal mailboxes will contain the same elements and characteristics, like public mailboxes, described above (e.g., receiving and observation windows etc.). The difference may be in dimensions, so personal mailboxes will be smaller and united to grids. Also, as mentioned earlier, personal mailboxes will have the separately installed cubicle for electronics. Final drawings will be shown in "APPENDIXES".

1) Casing (dimensions, painting). Outer casings may be manufactured from the stainless steel. Characteristics of the single personal mailbox may be the following: steel 2 mm, height 300 mm, width 250 mm, depth 100 mm. Those single personal mailboxes may be united to grids containing n-mailboxes plus the separate cubicle for electronics. In the future, dimensions of personal mailboxes united to grids may be heterogeneous (image below). For example, the main grid of mailboxes with equal dimensions, and extra grid of parcel boxes with larger dimensions.

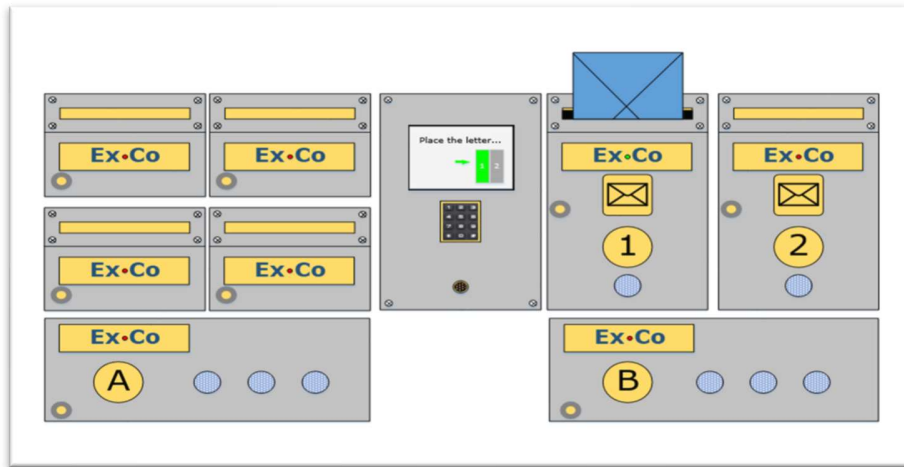

Image 3.7 Different dimensions of personal mailboxes:

The main grid of mailboxes with equal dimensions, and extra grids of parcel boxes with smaller/larger dimensions.

Characteristics of the separate cubicle for electronics may be the following: steel 2 mm, height 300 mm, width 250 mm, depth 150 mm. All preliminary dimensions may be updated in the process too.

As mentioned earlier, personal mailboxes from the galvanized steel may be used in the future. Those mailboxes may be painted to create multicolor personal mailboxes with pleasant design. As an example, for outer casings of personal mailboxes from galvanized steel may be used powder paint (using with the powder-coating technology, which helps to adhere to the steel surface for creating the homogenous, robust layer) for steels. This kind of paint has a lot of advantages. It is relatively inexpensive, highly aesthetic, has very good weather and anti-vandal protection characteristics. Some powder coatings are toxic. Therefore certified, non-toxic, hypoallergenic, innocuous powder coating must be used. For example, the certified Akzo Nobel powder paint may be used. Inner casings will provide place for correspondence, electronics and wiring. Also, it will help to split the mailbox for different parts for the comfortable maintenance.

2) Casing plates. Casing plates (e.g., nameplates) from plastic or aluminum will be used only for aesthetic and advertising purposes. They may be the same as for public mailboxes. For personal mailboxes from the galvanized steel plates may be replaced by painting too. For personal mailboxes on the grid, extra casing plates may be for flat numbers (or may be provided in place for this purpose, used paint etc.). For single personal mailboxes (e.g., for

the farmhouse, company) extra plates may show the number of the house, company name etc. Also, the extra casing plate must be installed to the separate cubicle for electronics to show, that this cubicle only for qualified personnel (e.g., an electrical hazard plate).

3) Doors (mechanical locks, hinges). Doors may be the same as for public mailboxes. Only dimensions will be smaller.

Mechanical locks will be used by receivers to open their own personal mailbox and get the correspondence. Also, mechanical locks will be used by the maintenance personnel to open the door of the separate cubicle for electronics.

Hinges may be the same as for public mailboxes (dimensions may be different).

4) Observation windows. Decorative observation windows for personal mailboxes may be the same as for public mailboxes. There is no need for the observation window at the separate cubicle for electronics.

5) Receiving windows. Receiving windows for personal mailboxes may be the same as for public mailboxes.

6) Fastenings. Allowable load for the grid of personal mailboxes may be calculated. Let's assume, that the weight of the grid will be 100 kg.

Final drawings for components of the casing will be shown in "APPENDIXES". Also, calculations in "ANSYS" will show possible deformations of the loaded mailbox and will be placed to "APPENDIXES" too.

3.2.2 The internal part of personal mailboxes and the separate cubicle for electronics

There will be electronics and wiring inside public mailboxes –locks and there will be the main part electronics and wiring - controllers, scanners etc. at the separate cubicle for electronics.

1) Controllers. The controller will be installed inside the separate cubicle for electronics. Like for public mailboxes, it will provide all controlling actions with codes, locks, scanners, keyboards etc. Controllers and equipment may be the same as for public mailboxes. The difference is in the places of installation. As mentioned earlier, all equipment for public mailboxes will be installed inside public mailboxes. For personal mailboxes, the main part of the equipment will be installed inside the separate cubicle for electronics. Heating elements will be not installed for personal mailboxes, because the weather resistance characteristics will be not mandatory. In the future, all exposed to risks equipment must be vandal resistant too.

2) Locks for the receiving window, keyboards, displays etc., may be the same as for public mailboxes.

3.2.3 The additional equipment

As mentioned earlier, all equipment and software for the project in the future may be changed to more trustworthy, expensive and appropriate equivalent. Also, in the future, different additional equipment may be used to facilitate the usage of mailboxes. Like for public mailboxes, the author may propose to use:

1) Motion sensors. Motion sensors have been explained above.

2) Infrared sensors to check the occupancy of the personal mailbox. In communication with additional LEDs those sensors may show to the receiver, that the correspondence is inside.

3) Security cameras. Security cameras have been explained above.

4) Additional backlight. Extra light will show the inner part of the personal mailbox. This light may be turned on at the moment, when the door is opened (e.g., using an extra limit switch).

5) Correspondence holders (newspaper holders, boxes, rolls). Holders (image below) will help to put spam correspondence for personal mailboxes of those receivers, who want to protect themselves against spam but, selectively, not completely (e.g., the receiver wants to keep under the control his "main" mailbox, but sometimes he is not totally against receiving advertisements to his "secondary" mailbox). Holders may solve two problems of the spam correspondence described at the beginning – a) the danger to lose important correspondence, b) the irritation of the spam. But other problems will remain unresolved.

3.2.4 The interim check

Updates for personal mailboxes will be done too. Will be created the separate cubicle for electronics. External and inner parts will be modified too. The result may be the following (image below):

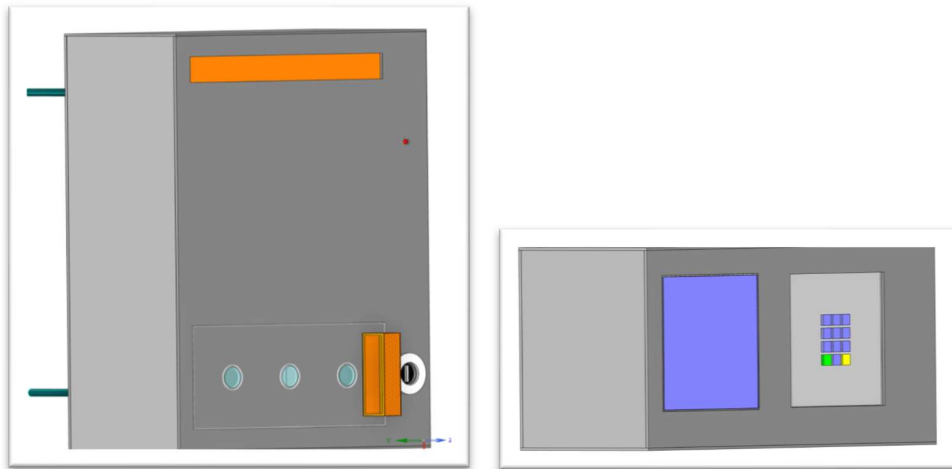

Image 3.8 The vision of the updated personal mailbox, the updated separate cubicle for electronics.

After all updates, the implementation of the preliminary prototype for personal mailboxes has been finished too, some main components have been physically installed and the preliminary vision of electronic connections has been made.

The next step is the implementation of the new controlling system.

3.3 The implementation of the new controlling system

Preliminary steps for prototypes of new mailboxes to block mailboxes physically from unauthorized access has been analyzed. The code for the new controlling system to allow only expected correspondence will be done. As mentioned earlier, in the future the new company website may be created (entities must communicate with each other). In the scope of this project, the full-fledged site will not be created. All communications and functions of the controlling system will be provided with the programming language C++ (suitable for Arduino Mega 2560). In the future, the full-fledged website (which will provide all communications and functions of the controlling system). From all the above, the "server" will be described in theory too.

3.3.1 The "server"

Also, as mentioned in the beginning, the "server" – in the scope of this project is some "master unit" (master controller), which will help to achieve objectives (e.g., to generate different algorithms, codes, to rule slave controllers, to send notifications and to show all communications between entities etc.). In other words, this may be some central control unit

with the connected components for access control and rack monitoring. In the future, that may be possible to use ready-made solutions (with special software) for such kind of equipment. For example, master control unit 3000-U141-02 (interfaces: serial RS 232C, Ethernet, 100 Mbit, RJ45) for the electromechanical locking system with the control cockpit Emka 3000-U68-103 (images below), which can rule, log and document all accesses, communications, measures between slave equipment may be used. There will be different types of standards, protocols depending on the future system (e.g., RS-485, TCP/IP etc.).



Image 3.9 The master control unit 3000-U141-02 with the control cockpit Emka 3000-U68-103

This master controller will control the work of access and sensor units (slave controllers) and further other equipment (locks, sensors etc.). For example, Emka equipment may be used too. For the preliminary coding, the Arduino controllers (e.g., Arduino uno Wi-Fi rev2 controller) may be used for all "server's" tasks.

3.3.2 The updated logical schema

Preliminary logical schema has been shown in the paragraph "2.1.5 Entity-relationship model (ER model)". The updated logical schema will show step by step relationships between all entities. Some steps may be simultaneous. The author must warn that these steps are only for information and help to understand the idea better. That is the preliminary vision of how the algorithm will work in the real project (with the real company). The preliminary prototype may use more simplified steps, some steps may be ignored, changed or updated.

1) Step 1. The registration of the new personal mailbox. A customer will buy the new personal mailbox (or the grid of mailboxes). At the time of the purchase, the customer will get the personal ID code for his personal mailbox too (the ID code for the personal mailbox will be unique for each mailbox). At the same time the customer will be registered on the full-fledged website (using secure authentication for e-services ID-card, Mobil ID, Smart ID, EU eID etc.)

as a new user. As mentioned earlier, in the scope of this project, the word "server" will be used to show all communications between entities. The "server" will get data about the customer (surname, family name, postal address). As mentioned earlier, for the preliminary prototype, the Arduino Mega 2560 Rev3 controller (or another) may be used. There must be selection too. The new customer will choose between two checkboxes (is the new mailbox owner a private person or a company).

Main fields in the registration form will be the postal address and the ID code of the personal mailbox. The postal address will be chosen from the dropdown list. There will be not possible to register the address which does not exist in the database or to ignore this field. This step may be shown with the programming language C++. The full code will be presented completely in "APPENDIXES". As mentioned earlier, the interim check will show possible updates later.

2) Step 2. The registration of the sender. The sender decides to send a letter. To send it, the sender must register himself on the full-fledged website using secure authentication for e-services too (this registration must be unique). The sender may not have his own personal mailbox, but the sender must be registered and get his unique ID to avoid multiply registrations.

Of course, at the beginning, the sender will not have any mailboxes and even will not register himself. The predicted algorithm will be the following: 1) the sender will send the letter 2) the postman will see that the personal mailbox is blocked 3) the postman will return the letter to the sender. This is a big problem. But this problem may and will be resolved successfully (e.g., by the PR company or even by returning the financial expenses within the amount of the envelope price to the sender for the first time with the explanations, by using correspondence holders etc.). The more people met with the new conception of personal mailboxes, the fewer problems like this will appear. In the scope of this project, let's assume, that the sender already knows, that the receiver has the new personal mailbox. Other problems may occur, like the problem described above. Therefore, the author repeats, that in the scope of this this project, there is only the preliminary explanation of the new idea. For example, the author does not explain safety precautions. May occur, that the closing receiving window will injure the sender or the postman. All aspects must be analyzed before the starting of the real project (in practice).

3) Step 3. Sending the letter. After the sender's registration is done, the sender must fill the special form at the "Main page" to send the letter. The main field within this form will be the receiver's postal address. The postal address will be chosen from the dropdown list too. There

will be not possible to send the letter to the address which does not exist in the "server's" database or to ignore this field. And the letter may be successfully sent only if all requirements have been met. This step may be simplified if the sender has registered himself (see the step 2 above).

4) Step 4. Code "A". The code "A" will be generated by the "server" only if the sender has successfully sent the letter through the website. This code will confirm, that both participants (the sender and the receiver) have been registered in the database and postal addresses are correct. The sender will get this code. This code will be used to put the letter to the new public mailbox. So, in other words, the code "A" is the sending code.

Again, returning to the problem described in the step 2, there is one more possible solution to resolve this problem. The contract with the third-party post-delivery companies may be concluded – to deliver the correspondence which is provided for the new personal mailboxes to the imaginary company's new public mailbox. This solution will reduce the burden on third-party post-delivery company's postmen. The imaginary new company's own postmen may take the "problem correspondence", deliver it and send notifications to the receiver for themselves. So, there are a few options of the resolving the problem, and they must have a great chance of success.

5) Step 5. Code "A" and public mailboxes. As soon the code "A" is received, the sender will use it near the new public mailbox. The sender does not need to wait the approval from the receiver to do this, because the receiver may ignore or make decisions with delay. **Only the presence of the code "A" is significant** for this step. The new public mailbox will accept or decline the code "A". The rejection is possible if the code is not correct. At this step, there is one more defense against the spam. If the "intruder" will decide to put the correspondence to the public mailbox with wrong, random codes, then the public mailbox will deny this request.

6) Step 6. Notification to the receiver. At the same time, the notification to the receiver will be sent, so this is an example of simultaneous steps. This notification will inform the receiver, that someone has sent the correspondence to him. The receiver can approve, decline, or ignore the correspondence. The notification may be sent in different ways (e.g, via SMS, APP notifications, e-mail etc.). This step must be provided only if the correspondence has successfully arrived at the public mailbox and not earlier. This requirement is important, because the sender can successfully make all steps before, but at the last moment will decide not to send the letter (simply will not put the letter to the new public mailbox). If the notification comes to the receiver earlier, then the receiver will vainly wait for the unsent correspondence.

7) Step 7. Code "B". If the receiver has approved the correspondence, then the code "B" will be generated by the "server". This code will be sent only to postmen. The receiver even does not need to know this code or to use it. In the scope of this project, postmen are already in the database. Also, as mentioned earlier, the code "B" will be described but only to understand the process better. It will be kept in mind, that in practice it will be taken away from the postman, "missing". The postman can use sorting device (e.g., scanner) to separate the correspondence in the public mailbox. So, approved correspondence may have one status, declined or "waiting for the decision" - another.

8) Step 8. Code "C". If the receiver has declined or ignored⁸ the correspondence, then the code "C" will be generated by the "server". This code has not been described above but must be embodied in logic too. This code must be sent only to postmen. In the future, (by the analogy with the code "B") this code will be not sent to postmen (this code will be described only to understand the process better. It will be kept in mind, that in practice it will be taken away from the postman, "missing").

9) Step 9. Notifications to the sender. As soon codes "B" or "C" are received, the sender will get a notification, that the correspondence has been approved or declined (ignored) by the receiver. If the code "B" has been received, then only information will be provided.

If the code "C" has been received, then the sender must choose – will postmen return the correspondence back to the sender or not. There will be few options to choose. Firstly, the sender may decide to send the correspondence back to him. This case is suitable if the sender has not the registered personal mailbox too (but the returning address is correct). Secondly, the returned correspondence may be sent to the mail office. The sender can take his correspondence back there. The third option is to refuse the return (to destroy the correspondence permanently). Also, the sender may ignore this notification. In this case, the correspondence will be destroyed too.

10) Step 10. Code "B" and personal mailboxes. The postman will empty the new public mailbox, according to the schedule. As soon the code "B" is received, the postman will use it near the receiver's personal mailbox. **Only the presence of the code "B" is significant** for this step. So, in other words, the code "B" is the approving code. As mentioned earlier, the code "B" will be described only to understand the process better. The personal mailbox will

⁸ In cases of ignoring, there will be a time delay for the decision (e.g., 3 days). If the receiver does not respond in 3 days, then the code "C" will be generated.

accept or decline the code "B". The rejection is possible if the code is not correct. At this step, there is one more defense against the spam (image below).

11) Step 11. Code "C" and different decisions.

a) Code "C" and personal mailboxes. As soon the code "C" is received and the sender has decided to get his correspondence back to his own address, the postman will use the code near the personal mailbox of the sender (if the sender has the registered personal mailbox) or simply will return the letter to the sender's common mailbox (if the returning address is correct). The step is similar with the step 10. The difference is only in the postal address – the postman will deliver the correspondence back to the sender, so in other words, the code "C" is the returning code.

b) Code "C" and the post office. As soon the code "C" is received and the sender has decided to get his correspondence back to the post office, the postman will bring the correspondence to the postal office. The sender can get it back using personal ID.

c) Code "C" and destroying of the correspondence. As soon the code "C" is received and the sender has decided to destroy the correspondence (or ignore the notification), the postman will bring the correspondence to the postal office. This correspondence will be permanently destroyed.

12) Step 12. Notifications to the receiver. As soon the correspondence is approved by the personal mailbox, the receiver will get a notification, that the correspondence has been arrived. This step resembles smart mailboxes, which are sending notification to the receiver, when the correspondence arrives (e.g., smart mailboxes from the "Parcelsea" company). Those mailboxes are using different kinds of sensors (e.g., motion, vibration sensors) to capture the moment of the correspondence's entering. The receiver can open the personal mailbox and retrieve the correspondence using a common lock. In the future extra notifications may be added too (e.g., notifications to the postal office, to the sender etc.).

3.3.3 Additional cases

In the future, may be situations, when the correspondence must be delivered without any restrictions, so-called "whitelist" sender's correspondence (e.g., government or bank notifications, preordered journals, newspapers etc.). In some cases, this type of correspondence may be already **preapproved** by the receiver (an analogy may be automatically payable e-invoices in banks). The "whitelist" is useful to facilitate the procedure of correspondence delivery if the sender is trustworthy. The new imaginary company may provide codes "A" and "B" or analogue, some "key to free pass" to allow the correspondence

to public and personal mailboxes without any delays and restrictions. The company may even use special company envelopes for these purposes (not mandatory but may increase the company's profit). At the first sight this decision will weaken the protection of mailboxes, but as mentioned above, this kind of correspondence will be trustworthy (the government) or preapproved by the receiver. The receiver can remove the sender from the "whitelist" at any moment.

Additionally, "whitelisted" codes may have the expired status, which may be limited in time (the analogue of subscription). What does it mean? For example, one the expired code will be suitable only for one month. After that the code will be irrelevant, expired and cannot be used to get access to mailboxes. The expired code does not mean, that already sent correspondence will disappear. This only means, that it will be impossible for senders to send expired envelopes in the future. Using the tactics of expired codes will provide a periodical rotation of "whitelist" senders and to decrease the number of codes (because expired codes may be used in the future again). Also, this will be an additional step for defending mailboxes from possible intrusion (e.g., this makes them less vulnerable to be guessed at through the e.g., brute-force method).

In contrast to the "whitelist" the "blacklist" (images below) may be used for unwanted senders. In this case, the sender will immediately (even without getting the code "A") get a notification, that he is in the "blacklist". The receiver will not get any notifications.

Receivers may start to get redundant notifications and requests for acceptance if they have declined the letter from the sender but have not "blacklisted" him. So, the paper spam problem may become the SMS/email spam problem. But the decision of this problem is very simple. As mentioned earlier, senders must be registered using secure authentication for e-services ID-card, Mobil ID, Smart ID, EU eID etc. This method will decrease the chance of repeated, multiply registrations. So, once, the spamming sender will be simply "blacklisted".

The "blacklist" may be used as a tool by the imaginary company's personnel, too. For example, the "intruder" may brim the public mailbox with spam without violating anything at the same time. The "intruder" may successfully register himself and send spam to himself or approved receivers in a huge, excessive amount. This "diversionary" tactic may create a "postal jam" because the public mailbox will be flooded with the spam. Such "intruders" may be "blacklisted" by the imaginary company's personnel, too. They will lose a chance to put the correspondence in public mailboxes at all. Alternatives of the permanent "blacklist" for "intruders" may consist of limiting the amount of daily correspondence.

Even with all preliminary precautions, cheating cases may still appear. The most obvious example will appear, if any unfair postman will decide to put spam correspondence simultaneously with the approved correspondence. The chance of this cheating case may be reduced if the receiving window will open only once and for a short time (time delay). If the postman has not managed to put the letter in time, then the code "B" will expire. There will be impossible to use this code again without the intervention of the imaginary company. Also, described above mechanical springs for the receiving window will help to create the illusion of permanently closed status of windows. So, the protection against the human's factor will appear here. As mentioned in the beginning, the eventual control of postmen's actions may be annoying for customers and there is no lawful leverage against unfair deliverymen who are putting spam. So, the expired code "B" will show to the postman's leadership, that the postman has made a mistake.

Also, security cameras may be used to reduce the chance of vandalism on the part of postmen (e.g., the unfair postman may block the receiving window physically). This should be considered too to use lawful influence in the future. As mentioned earlier, the best solution is to have the own postmen.

3.3.4 Interim check

The interim check has shown that the updated logic is a bit complicated for common users. It must be more facilitated and become in practice as simple as possible for users while retaining requirements, plusses and minuses and quality described earlier. What is difficult in practice? The abundance of codes is not user`s friendly approach. Of course, all theoretical decisions and solutions made earlier are necessary to understand the right direction, but in practice those decisions may be more simplified. The best solution in practice is to use scanners with barcodes. Within the prototype there will be the imitation of the scanner. The main idea will follow chosen conceptions, but some steps will be updated.

For imitation purposes, the author will not use expansion boards for electromechanical locks or servo valves but would confine himself with using LEDs. For the public mailbox the author will use code for two LEDs (e.g., red and green) to show the status of the receiving window.

If the receiving window is opened (access is allowed), then the green LED will work for e.g., 3 seconds. Otherwise (access is denied), the red LED will work. For personal mailboxes the author will use 4 green LEDs to imitate the opening of different personal mailboxes.

The second update is more significant and will influence to the internal part of public and personal mailboxes. The practice has shown that the controller Arduino Mega 2560 for the

prototype is not suitable for "server`s" tasks. Therefore, it must be changed to the analogue, which can use Wi-Fi interface to imitate the work of the "server". The simplest solution for the imitation of the prototype is for example to use low-cost and reliable Wi-Fi microchips ESP8266, with expansion development boards NodeMcu Lolin (image below). This module can be programmed, using Arduino IDE software, which is comfortable too (the user only needs to install appropriate free libraries).

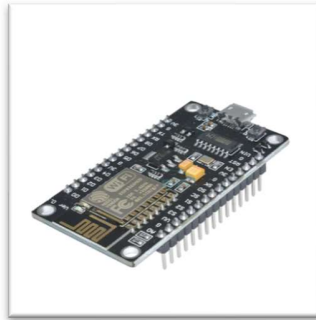

Image 3.10 The Node microcontroller ESP8266 (LOLIN CH340 chip) will be used only for the preliminary prototype.

There must be three separate controllers - for public, personal mailboxes and for the "server". In theory, those controllers may "communicate" between each other through the Wi-Fi.

3.4 The final result of the implementation

The final solution has been implemented and all elements (public mailboxes, personal mailboxes with the separate cubicle for electronics, the controlling system) have been reviewed in detail. All theoretical calculations and illustrations have been done (mainly in "APPENDIXES"). The next step is a practical check of the coding part of the extremely simplified "prototype". This step will be reviewed in the next chapter. The prototype will use data from conceptions chosen before. The purpose of the check is to show, that the code will compile. This will mean, that in the real prototype in the future mailboxes can work and communicate with each other.

4. FUNCTIONAL TESTS OF THE CODE

The purpose of this chapter is to provide functional tests of the code. This will help to reaffirm the theoretical part. Of course, interim checks have helped to find "mistakes" which were invisible during theoretical analyses and some steps were simplified too. So, the functional test will mainly reaffirm theoretical analyses with updates made during interim check. If the functional test will be successful, then the code works correctly. If functional tests will be unsuccessful, then further updates and improvements will be done.

4.1 The testing process

Steps and results of functional tests of the code for the preliminary prototype will be shown below.

1) Step 1. Firstly, the prototype will connect to Wi-Fi to imitate the job of the "server". The main code will be shown in "APPENDIXES". Code elements within this chapter will show main steps. All libraries, information and generally accepted code elements for the preliminary code (e.g., "...pinMode(ledPin, OUTPUT);...") have been found in the free access (e.g., <https://docs.arduino.cc>).

```
char ssid[] = "Kangelaste10";// the author's Wi-Fi identifier
char pass[] = "1s2p3R";// the author's Wi-Fi password
WiFiServer server(80); // free chosen port

IPAddress ip(192,168,1,200);// free chosen IP address of the server
IPAddress gateway(192,168,1,1);// the author's gateway of the network
IPAddress subnet(255,255,255,0);//the author's subnet mask of the network

void setup() { //main part of the programm. Will be used once.
  Serial.begin(115200);//begin
  WiFi.config(ip, gateway, subnet);// forces to use the fix IP
  WiFi.begin(ssid, pass);// connection to the Wi-Fi router
  while (WiFi.status() != WL_CONNECTED) { /*condition for the connection. While we have no connection to Wi-Fi there
will be typing symbols "."(dot) to show the process*/
    Serial.print(".");
    delay(500);//time delay between typing symbols
  }
  server.begin();// starting the server
```

Image 4.1 Results of testing the step 1.

2) Step 2. Putting the letter to the public mailbox. Red LED will imitate the declined status, green - accepted.

```
if (answer == "Yes") { //accepted letter
    lcd.clear(); //clean the LCD screen data
    lcd.setCursor(0, 0); //place the cursor at the beginning
    lcd.print("APPROVED"); //print at the first row of the lcd screen
    lcd.setCursor(0, 1); //put the to the second row
    lcd.print("put your letter"); //print at the second row of the lcd screen
    digitalWrite(led_green, HIGH); //the green LED is active
    delay(3000); //time delay while the receiving window is opened
    digitalWrite(led_green, LOW); //the green LED is non active after the delay
    /*this will imitate the opening of the receiving window*/
    lcd.clear(); //clean the LCD screen data
} else { //the same code for declining the letter
    lcd.clear();
    lcd.setCursor(0, 0);
    lcd.print("DECLINED");
    lcd.setCursor(0, 1);
    lcd.print("sorry");
    digitalWrite(led_red, HIGH);
    delay(3000);
    digitalWrite(led_red, LOW);
    lcd.clear();
}
    lcd.clear();
}
```

Image 4.2 Results of testing the step 2.

3) Step 3. Putting the letter to the personal mailbox.

```

if (answer == "Return") { //case for returning. So called code "C"
    lcd.clear();
    lcd.setCursor(0, 0);
    lcd.print("RETURN letter");
    lcd.setCursor(0, 1);
    lcd.print("to sender");
    digitalWrite(led_red, HIGH); /*we have one red LED to show, that access to personal mailboxes is denied*/
    delay(3000); //delay for debugging
    digitalWrite(led_red, LOW);
    lcd.clear();
}
if (answer == "No") { /*case for "spammers". This person can not put any spam inside*/
    lcd.clear();
    lcd.setCursor(0, 0);
    lcd.print("FORBIDDEN");
    lcd.setCursor(0, 1);
    lcd.print("sorry");
    digitalWrite(led_red, HIGH);
    delay(3000);
    digitalWrite(led_red, LOW);
    lcd.clear();
}
if (answer == "Wait") {
    lcd.clear();
    lcd.setCursor(0, 0);
    lcd.print("Please WAIT");
    lcd.setCursor(0, 1);
    lcd.print("for decision");
    digitalWrite(led_red, HIGH);
    delay(2000);
    digitalWrite(led_red, LOW);
    lcd.clear();
}
}

```

```

if (answer == >>> ) { /* case for allowed correspondence for the random imaginary personal mailbox. So called code "B". In this case number >>>*/
    lcd.clear();
    lcd.setCursor(0, 0);
    lcd.print("Put letter to ");
    lcd.setCursor(0, 1);
    lcd.print("555");
    digitalWrite(led_555, HIGH);
    delay(3000); //time delay while the receiving window is opened
    digitalWrite(led_555, LOW);
    lcd.clear();
}
if (answer == "777") { // - number 777
    lcd.clear();
    lcd.setCursor(0, 0);
    lcd.print("Put letter to ");
    lcd.setCursor(0, 1);
    lcd.print("777");
    digitalWrite(led_777, HIGH);
    delay(3000);
    digitalWrite(led_777, LOW);
    lcd.clear();
}

lcd.clear();
}

```

Image 4.3 Results of testing the step 3.

The code has been debugged successfully. Functional tests of the coding part show that the code works correctly.

4.2 The evaluation and plans

The preliminary code for future "prototypes" of mailboxes has been successfully tested. Functional tests have shown that the idea could work in practice. This gives a possibility to update the preliminary prototype with more complex equipment and software and to create the real company, which will sell new mailboxes with the new controlling system. Of course, in the future for the real company more advanced research must be done for resiliency of the whole system (e.g, FMEA (Failure mode and effects analysis) or FMECA (Failure mode effects and criticality analysis) processes).

SUMMARY

The principle of creation the anti-spam defending system for letterboxes has been shown as the first step for more deepen analyze. The idea is working, but the creation of the real system needs more updated equipment and software. Even the creation of the prototype must use more complicated solutions to understand all possible problems, threats etc.

LIST OF REFERENCES

L1. Laws, surveys.

* Survey on „scams and fraud experienced by consumers” 2020 Produced by Consumers, Health, Agriculture and Food Executive Agency (Chafea)
https://ec.europa.eu/info/sites/default/files/aid_development_cooperation_fundamental_rights/ensuring_aid_effectiveness/documents/survey_on_scams_and_fraud_experienced_by_consumers_-_final_report.pdf

* Elanike demograafiline jaotus KOV-de kaupa 2021

<https://www.elvl.ee/elanike-arv>

* The Estonian Commercial Code („Äriseadustik”)

<https://www.riigiteataja.ee/akt/130112022007?leiaKehtiv>

* The Postal Law („Postiseadus”)

<https://www.riigiteataja.ee/akt/113032019115?leiaKehtiv>

* Annual fraud report

https://www.ukfinance.org.uk/system/files/2022-06/Annual%20Fraud%20Report%202022_FINAL_.pdf

* Investigation on mechanical behavior and material characteristics of various weight composition of SiCp reinforced aluminum metal matrix composite (Sivachidambaram Pichumani, Raghuraman Srinivasan, Venkatraman Ramamoorthi PhD Research Scholar, Corresponding Author, Professor, Professor, School of Mechanical Engineering, SASTRA University, Thanjavur, India 613401)

L2. The equipment.

* Controller Arduino Mega 2560 Rev3

<https://store.arduino.cc/products/arduino-mega-2560-rev3>

<https://images.theengineeringprojects.com/image/webp/2018/06/introduction-to-arduino-mega-3.png.webp?ssl=1>

* Controller AM8046

<https://eboxlock.en.made-in-china.com/productimage/yXGQhcnjHmRN-2f1j00KAitnMglMFuC/China-Parcel-Locker-System-Master-Controller-with-4G-and-Open-Protocol-AM8046-.html>

* Electromagnetic lock

<https://robotechshop.com/shop/%E2%80%A2miscellaneous/dc-6v12v-electric-solenoid-lock-small/>

* Mechanical lock Emka 1000-SU951-RE

https://www.emka.com/products/de_en/1000-su951-re

* Hinge Emka 1031-U2

https://www.emka.com/products/de_en/1031-u2

* Electromechanical lock Kenrone IP65

<https://www.amazon.com/KENRONE-Electromechanical-Electronic-Cabinet-Waterproof/dp/B09W9QSRXS>

* The touchscreen Mimo MOD-10180CH

<https://www.touchwindow.com/p/MOD-10180CH.html>

* The keyboard Emka 3000-U45-05

https://www.emka.com/products/de_en/3000-u45-05

* The master control unit Emka 3000-U141-02

[Control Unit Wireless; 3000-U141-02 \(emka.com\)](https://www.emka.com/products/de_en/3000-u141-02)

* The control cockpit Emka 3000-U68-103

[EMKA Control Cockpit, extension for 20 further system \(Control Unit\); 3000-U68-103](https://www.emka.com/products/de_en/3000-u68-103)

* The indoor thermostat Eberle FTR-E 3121

<https://www.conrad.com/p/eberle-ftp-e-3121-indoor-thermostat-surface-mount-20-up-to-35-c-613121>

* The LED green for Arduino

<https://www.perintang.com/wp-content/uploads/2019/03/LED5G.jpg>

* The LED 0035.0668 SCHURTER

<https://media.digikey.com/Photos/Schurter%20Photos/0035.0668.jpg>

* The scanner SSTC-JL-5066

<https://komplektuhi.net/catalog/shtrih-code-scfneri/sstc-jl-5066>

* The power supply LRS-100

<https://www.meanwell-web.com/en-gb/ac-dc-single-output-enclosed-power-supply-lrs-100--12>

* The keypad (4x4) for Arduino

<https://www.circuitbasics.com/how-to-set-up-a-keypad-on-an-arduino/>

*

L3. Other.

* Free symbol of the hand used for the image

<https://www.vecteezy.com/vector-art/6243591-click-hand-pointer-black-finger-touch-screen-symbol>

* Free symbol of the apologizing used for the image

<https://www.vecteezy.com/vector-art/8631750-apology-tag-filled-line-icon>

* Free symbol of the approving used for the image

<https://www.vecteezy.com/vector-art/4633734-green-check-mark-icon-button-vector-illustration>

* Smart mailboxes from the "Parcelsea" company

[Smart Mailbox: These Options Are Available - Parcelsea](#)

L4. List of images and tables.

Image 1.1 The survey on "scams and fraud experienced by consumers"

Image 1.2. The junk correspondence in personal mailboxes

Image 1.3 The Gantt chart with "time anchors"

Image 2.1 The black box

Image 2.2 The scoring table for the preliminary financial reasonability analysis survey

Image 2.3 The preliminary conceptual schema

Image 2.4. The preliminary logical schema

Image 2.5 The functional model

Image 2.6 The conception 1 for public mailboxes

Image 2.7 The conception 2 for public mailboxes

Image 2.8 The conception 3 for public mailboxes

Image 2.9 The conception 4 for public mailboxes

Image 2.10 The conception 5 for public mailboxes

Image 2.11 Updates for the conception 4 for public mailboxes

Image 2.12 The conception 1 for personal mailboxes

Image 2.13 The conception 2 for personal mailboxes

Image 2.14 The conception 3 for personal mailboxes

Image 2.15 The conception 4 for personal mailboxes

Image 2.16 The conception 5 for personal mailboxes

Image 2.17 The conception 1 for the controlling system

Image 2.18 The conception 2 for the controlling system

Image 2.19 The conception 3 for the controlling system

Image 2.20 The conception 4 for the controlling system

Image 2.21 The conception 5 for the controlling system

Image 3.1 An example of external casing plates

Image 3.2 The lock Emka 1000-SU951-RE, the hinge Emka 1031-U2

Image 3.3 Standards of envelopes and dimensions of the receiving window.

Image 3.4 The controller AM8046, the electromechanical lock Kenrone, the keyboard Emka 3000-U45-05, the touch display Mimo MOD-10180CH, the LRS-100 power supply, the Eberle FTR-E 3121 indoor thermostat, the LED 0035.0668 Schurter

Image 3.5 The preliminary vision of possible installation of the receiving window with the electronic lock.

Image 3.6 The vision of the updated public mailbox.

Image 3.7 Different dimensions of personal mailboxes

Image 3.8 The vision of the updated personal mailbox, the updated separate cubicle for electronics.

Image 3.9 The master control unit 3000-U141-02 with the control cockpit Emka 3000-U68-103

Image 3.10 The Node microcontroller ESP8266 (LOLIN CH340 chip) will be used only for the preliminary prototype.

Image 4.1 Results of testing the step 1.

Image 4.2 Results of testing the step 2.

Image 4.3 Results of testing the step 3.

Table 1.1 The schedule table

Table 2.1 The morphological analysis of the general criteria (material)

Table 2.2 The morphological analysis of the general criteria (shape)

Table 2.3 The scoring matrix of the general criteria (material)

Table 2.4 The scoring matrix of the general criteria (shape)

Table 2.5 The morphological analysis of public mailboxes

Table 2.6 The scoring matrix of public mailboxes

Table 2.7 The morphological analysis of personal mailboxes

Table 2.8 The scoring matrix of personal mailboxes

Table 2.9 The morphological analysis of the controlling system

Table 2.10 The scoring matrix of the controlling system