



TALLINN UNIVERSITY OF TECHNOLOGY
SCHOOL OF ENGINEERING
Department of Mechanical and Industrial Engineering

RELOCATION AND LAYOUT OPTIMISATION OF WINDAK OÜ FACTORY

TOOTMISSETEVÖTTE KOLIMINE JA TOOTMISE PARENDAMINE WINDAK OÜ NÄITEL

MASTER THESIS

EM70LT

Student: Reti Kullerkupp

Student code: 182528MARM

Supervisor: Kristo Karjust, Professor

Tallinn 2020

AUTHOR'S DECLARATION

Hereby I declare, that I have written this thesis independently.
No academic degree has been applied for based on this material. All works, major viewpoints and data of the other authors used in this thesis have been referenced.

"....." 20....

Author:
/signature /

Thesis is in accordance with terms and requirements

"....." 20....

Supervisor:
/signature/

Accepted for defence

"....."20... .

Chairman of theses defence commission:
/name and signature/

Non-exclusive Licence for Publication and Reproduction of Graduation Thesis¹

I, Reti Kullerkupp (name of the author) (date of birth: 19.03.1993) hereby

1. grant Tallinn University of Technology (TalTech) a non-exclusive license for my thesis

Relocation and layout optimisation of Windak OÜ factory,

(title of the graduation thesis)

supervised by Kristo Karjust,

(Supervisor's name)

1.1 reproduced for the purposes of preservation and electronic publication, incl. to be entered in the digital collection of TalTech library until expiry of the term of copyright;

1.2 published via the web of TalTech, incl. to be entered in the digital collection of TalTech library until expiry of the term of copyright.

1.3 I am aware that the author also retains the rights specified in clause 1 of this license.

2. I confirm that granting the non-exclusive license does not infringe third persons' intellectual property rights, the rights arising from the Personal Data Protection Act or rights arising from other legislation.

¹ *Non-exclusive Licence for Publication and Reproduction of Graduation Thesis is not valid during the validity period of restriction on access, except the university's right to reproduce the thesis only for preservation purposes.*

Reti Kullerkupp (*signature*)

25.05.2020 (*date*)

Department of Mechanical and Industrial Engineering

THESIS TASK

Student: Reti Kullerkupp, 182528MARM
Study programme, main speciality: Industrial Engineering and Management
Supervisor: Associate Professor, Kristo Karjust, +37256203260
Consultants: Madis Tomson, Plant Manager,
Windak OÜ, +372 568 400 16,
madis.tomson@windakgroup.com

Thesis topic:
Relocation and layout optimisation of Windak OÜ factory
Tootmisettevõtte kolimine ja tootmise parendamine Windak OÜ näitel

- Thesis main objectives:**
1. Present a new layout for the relocation project which reduces waste
 2. Present developments to improve factory efficiency
 3. Present a relocation plan for efficient moving

Thesis tasks and time schedule:

No	Task description	Deadline
1.	Formulating Master's thesis	01.02.20
2.	Overview of the company, Literature review	14.02.20
3.	Old factory layout and processes analysis	01.03.20
4.	New factory layout, improvements and relocation plan	20.04.20
5.	Financial calculations, drawings and conclusion	11.05.20

Language: English **Deadline for submission of thesis:** "25" May 2020

Student: Reti Kullerkupp "25" May 2020
/signature/

Supervisor: Kristo Karjust "25" May 2020
/signature/

Consultant: Madis Tomson "22" May 2020
/signature/

Head of study programme: Kristo Karjust "25" May 2020
/signature/

Terms of thesis closed defence and/or restricted access conditions to be formulated on the reverse side

CONTENTS

CONTENTS.....	5
PREFACE	7
List of abbreviations and symbols	8
List of figures	9
List of tables	10
INTRODUCTION.....	11
1 OVERVIEW OF WINDAK OÜ	13
1.1 Overview of the products	14
1.1.1 Intake and quality devices.....	15
1.1.2 Coiling/spooling machines	16
1.1.3 Packing machines.....	16
1.2 Overview of the main customers	17
1.3 Windak OÜ work structure description.....	18
1.4 Overview of the current production.....	21
1.4.1 Overview of the assembly area	22
1.4.2 Overview of the manufacturing area	22
1.4.3 Overview of the warehouse area	23
1.4.4 Problems in the current production	24
1.5 Main reasons for relocating the factory.....	24
2 THEORETICAL BACKGROUND	26
2.1 Different moving strategies	26
2.2 Planning the factory relocation	27
2.2.1 Transferring the property	29
2.3 Lean manufacturing method to identify the waste	30
2.4 Key performance indicators to measure the performance	31
3 WINDAK OÜ OLD FACTORY PRODUCTION FLOW ANALYSES	33
3.1 Overview of the old production flow based on assembly 02-4005-B2	34
3.1.1 Designed subcontracted part 20-078729-1 flow	37
3.1.2 Designed self-produced part 20-022000.....	38
3.1.3 Purchased standard part 81-000345 flow	41
3.1.4 Assembly 02-4005-B2 flow	42
4 WINDAK OÜ NEW FACTORY PRODUCTION FLOW ANALYSES.....	44
4.1 New and old factory layout comparison	46
4.1.1 Designed subcontracted part 20-078729-1 flow	49
4.1.2 Designed self-produced part 20-022000 flow	50
4.1.3 Purchased standard part 81-000345 flow	51

4.1.4	Assembly 02-4005-B2 flow	51
4.2	KPI analysis comparing old and new factory	52
5	IMPROVEMENTS FOR THE NEW FACTOR	56
5.1	Improvements in the manufacturing area	57
5.2	Improvements in the warehouse area	59
5.3	Improvements in the assembly area	61
6	RELOCATION ACTION PLAN	64
7	FINANCIAL CALCULATIONS	68
7.1	Payback period for improvements.....	69
	CONCLUSION.....	70
	KOKKUVÕTE	72
	LIST OF REFERENCES	74
	APPENDICES	76
	GRAPHICAL MATERIALS	82

PREFACE

This thesis is initiated by Reti Kullerkupp, who has previously worked at Windak OÜ as a Mechanical Designer and as a Project Coordinator. Windak OÜ needs a bigger production area to satisfy increasing demand for cable packaging machinery.

Windak OÜ is producing automatic machines that are being designed, assembled and tested by themselves.

The author would like to thank Windak OÜ staff for the help that they have put into this work.

Keywords: relocation, layout, improvements, master thesis

List of abbreviations and symbols

3D – Three dimensional views

CE – Conformité Européene (English: European Conformity), a certification mark in Europe

CNC – Computer numerical control

ERP - enterprise resource planning

ETO - Engineer to order

EUR – Euro

KPI - Key performance indicator

PLC - Programmable logic controller

RACI – Responsible, assists, consulted, informed

TIMWOODS – transport, inventory, motion, waiting, overproduction, over-processing, defects, skills

WIP - Work in progress

List of figures

Figure 1.1 Windak OÜ turnover from 2012-2018	13
Figure 1.2 Windak machine end product; cable coil and spool [2][3]	14
Figure 1.3 Windak line [2]	15
Figure 1.4 Similarities and differences between ETO and MTO	18
Figure 1.5 Windak OÜ workflow	19
Figure 1.6 Detailed process from parts arriving to packing	20
Figure 1.7 Old factory areas	21
Figure 2.1 Cost for design changes [10]	28
Figure 2.2 The planning process for manufacturing facilities [11]	28
Figure 3.1 Assembly components	34
Figure 3.2 Windak length counter 02-4005-B2	35
Figure 3.3 Different part flows in the old factory	36
Figure 3.4 Part 20-078729-1 sketches	37
Figure 3.5 Part 20-022000 sketches	39
Figure 3.6 Part 81-000345 product picture [21]	41
Figure 4.1 New factory areas	45
Figure 4.2 Possible location for welding station	47
Figure 4.3 Shelves accessed outside of the warehouse	47
Figure 4.4 Mechanical pre-assembly stations	48
Figure 4.5 Old factory part flows	53
Figure 4.6 New factory part flows	53
Figure 5.1 Improvements in the new factory	56
Figure 5.2 Cantilever rack with pull out system [23]	57
Figure 5.3 Kanban label and card sketches	60
Figure 5.4 Pre-assembly station furniture [25]	62
Figure 5.5 Pre-assembly computer station [27] [28]	63
Figure 6.1 Gantt chart for relocation project	66

List of tables

Table 1.1 Area of the old production facilities	21
Table 1.2 Manufacturing machines at Windak OÜ.....	23
Table 2.1 Main Advantages and disadvantages for different strategic options	27
Table 2.2 8 types of waste in production [15]	30
Table 3.1 Assembly 02-4005-B2 main parameters	34
Table 3.2 Assembly code descriptions	35
Table 3.3 Part 20-078729-1 main parameters	37
Table 3.4 Part 20-078729-1 flow in the old factory	38
Table 3.5 Part 20-022000 main parameters	38
Table 3.6 Part 20-022000 flow in the old factory	40
Table 3.7 Part 81-000345 main parameters	41
Table 3.8 Part 81-000345 flow in the old factory	41
Table 3.9 Assembly 02-4005-B5 old flow	42
Table 4.1 Area of the new production facility	45
Table 4.2 Old and new production departments comparison	46
Table 4.3 Part 20-078729-1 flow in the new factory	49
Table 4.4 Part 20-022000 flow in the new factory	50
Table 4.5 Part 81-000345 flow in the new factory	51
Table 4.6 Assembly 02-4005-B2 flow in the new factory	51
Table 4.7 Old and new factory difference in KPIs	54
Table 4.8 Improvements gain calculation.....	55
Table 5.1 Labelling system for warehouse inventory	59
Table 6.1 RACI matrix for relocation project.....	65
Table 7.1 Cost for improvements	68
Table 7.2 Improvements cost and gain.....	69

INTRODUCTION

The main objective of this thesis is to generate a plan of how to relocate a factory without stopping production for more than 4 weeks. Also, new layout with improvements for optimising the production is brought out and analysed.

To develop the relocation plan, a study was conducted on what are the different moving strategies, how to plan relocation and how to transfer inventory and knowledge. To present the potential layout with improvements, the manufacturing methods and how to measure their efficiency are described. Part flows were analysed at the old factory and bottlenecks were identified in order to optimise the new layout. Improvements were proposed to decrease the waste that was discovered during the analysis.

Windak OÜ is a subsidiary of Windak Group, owned by US and Australian shareholders. Windak Group produces and sells customised cable packaging machinery for cable producers. Windak OÜ has had increasing turnover since 2012. In 2017 the turnover was 6,24 million Euros, in 2018 the turnover reached 7,18 million Euros. [1] The increased turnover is due to the growing volume of machines being developed, assembled and tested at Windak OÜ. This has created a need for bigger and higher capacity production halls.

Windak OÜ is responsible for designing, assembling, and testing of Windak lines. Windak Group underwent structural changes in 2019 where spare parts and service departments in Sweden were closed and moved to Windak OÜ. This change increased the quantity of orders processed through Estonia. Windak OÜ has started to manufacture some non-standard parts in house. To reach the company goal of producing 50% of non-standard details in house, more processing machines are required which creates a need for more space in the production hall.

Increased turnover and the goal to manufacture more details in house are the main triggers for moving to a new factory. The relocation project started in January 2020 with the idea of modelling a detailed relocation plan as a master thesis. This thesis will convey the findings of research performed on factory relocation topics and propose how to improve the new factory layout to decrease waste. KPIs are used to measure the efficiency of the new layout. Step-by-step moving process is described to decrease the moving time.

The final outcome of the thesis will be presented and evaluated personally by the author of the thesis.

Keywords: relocation, layout, improvements, master thesis

1 OVERVIEW OF WINDAK OÜ

Windak OÜ was established in 2004 by Windak Holding AB. Windak Holding AB was established in 1994 in Sweden. Windak companies from Sweden, US, Australia and Estonia form a Windak Group. Windak Group is the largest supplier of automatic packaging equipment for the cable industry in North America. Its products have been delivered to 30 countries worldwide. [2] In 2018 70% of Windak Group machinery was exported to the US. [1]

The primary responsibility of Windak OÜ has been production which includes development, procurement, assembly, testing and installation of Windak Group machines. In 2019 Windak Group went through a structural change where spare parts and service department were added to Windak OÜ responsibility. Turnover of Windak OÜ has risen every year since the economic downfall started to recover in 2012, depicted in Figure 1.1. The increase in turnover has been achieved by selling more products which creates demand for bigger and smarter manufacturing areas. This has been one of the triggers to look for a new factory.

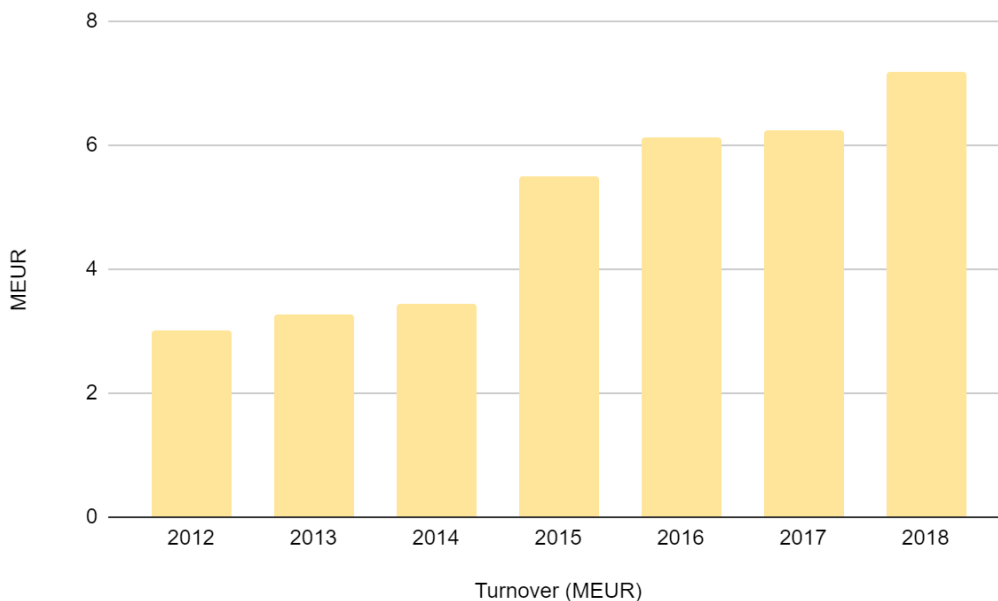

Figure 1.1 Windak OÜ turnover from 2012-2018

Windak OÜ will be moving to a new factory in Peetri in June 2020. A new building was chosen so the facility is built according to the requirements of the company. Also the increase in customers visits and inspections at Windak Group manufacturing sites, both prior to ordering and before acceptance, is a contributing factor in the selection of a new facility as it will be a positive representation of Windak to customers.

1.1 Overview of the products

Windak Group sells customized packaging lines to cable manufacturers. A line is called a full set of machines that customers purchase. A line can be a solo machine or it can consist of several products. The primary function for these machines are winding a cable, which has been produced by the customer, to a spool or into a coil (Figure 1.2) and packing it for transport. Projects commonly consist of an accumulator, coiler or spooler and a palletizer. The difference between coilers and spoolers are that coilers make a cable coil while spoolers put cable on a spool.



Figure 1.2 Windak machine end product; cable coil and spool [2][3]

The Windak line is usually divided into three main parts, where intake and quality is the first one, then comes the main machine and packing part is the end of the line. In between each machine there can be cable quality control equipment, labelling or boxing machines. Figure 1.3 describes a line with a pay-off, an accumulator, test equipment, spooler, conveyors and a palletizer. All machines from Windak are produced according to EU standards of safety and quality. All the machines that are sold to the EU have CE certification. Windak has created an ISO procedure for following the CE safety requirements. [4]



Figure 1.3 Windak line [2]

1.1.1 Intake and quality devices

Intake part of the line consists of pay-offs, accumulators, length counters and quality control devices. The goal is to feed the cable to the main machine as evenly as possible, while selecting high quality cables to run through the main machine and reject faulty material.

Pay-off is a device for customers who don't pack cable directly from the extruder line. Instead, they gather large reels full of cable and once the cable is ready for packing, place them on the pay-off machine that will feed the cable to the Windak. Accumulator is for temporarily storing cable that comes from an extruder or pay-off. There is a period where the main machine has stopped coiling/spooling and is in the process of cutting the cable and moving the coil/spool away to start a new one. At that time the extruder or pay-off is still outputting new cable and that new cable is being stored in the accumulator. Length counters measure the length of a cable to have coils/spools with correct length. This device has crucial importance since Windak machines produce packages ready to be sold to end customers. Quality control devices control the cable quality that comes from extruder and alerts the cable producer when cable does not meet requirements. Rejected cable will be separated from the good cable. Quality control devices are spark testers that measure the electrical conductivity and lump detectors that measure cable insulation thickness and regularity.

When the cable has gone through the first part of the line the cable is ready for the main machine to be coiled or spooled.

1.1.2 Coiling/spooling machines

Windak has several types of main machines that differ from each other by being spoolers or coilers and the intake/output speed, cable size capacity and also which market it is intended for.

Spoolers are the most advanced machines with the highest intake/output. Windak machines can use different sizes of spools on their machines. The sizes vary from 165 mm up to 800 mm in diameter. The spool output rate varies from 2 spools per minute to 4,6 spools per minute, depending on the size of the spool and the diameter of the cable. The diameter of the cable can be from 1,6 mm to 30 mm. The smallest spools with smaller cable can be spooled quicker and bigger cable to big spools takes more time to spool.

Coilers produce simpler products and therefore the machine is simpler also. The coil sizes are between 120 mm and 480 mm. Since coils are easier to produce, the output of the machine can be up to 12 coils per minute. The diameter of the cable can be 2,5 mm up to 20 mm.

Customers need to know their requirements when choosing a Windak machine. Since Windak makes customized production lines then every customer can have a product individually tailored to suit their production.

1.1.3 Packing machines

The last part of the Windak line is packing up coils or spools that have come out from the main machine. There can be labelling machines, boxing machines, heat shrink tunnels and palletizers. Main machine and packing part is connected with a conveyor. Labelling machines add labels to coils or spools and boxing machines put coils/spools into cardboard boxes and seals the boxes. There can also be a second labelling

machine that puts labels on the boxes. Heat shrink tunnels are one possibility to extra secure the wrapping of the coils.

The main part of the packing is the palletizer. Palletizer is a Cartesian robot that has a rectangular configuration. Palletizer has a gripper on three axes to lift, move and place a coil/spool to a pallet. First axis moves the gripper up and down for taking and placing the product, the second axis moves the product from conveyor to a pallet and the third axis is used to place the product to the correct space on a pallet. The pallet is also on a special conveyor that sends full pallets to the wrapping area to wrap it in plastic.

A pallet full of cable coils/spools is the final output of Windak lines. These pallets are ready for the end customer.

1.2 Overview of the main customers

Windak customers are cable producers who want to reduce human labour costs or who need an upgrade from older versions of packaging lines. Windak has reached all the continents of the world. Most sold areas are North-America and Europe.

The customers vary greatly in production volume. Some customers need to have the machines running 24/7 and may be stopped only a few days per year for maintenance, while others work 8 hour shifts 5 days per week and turn off the machine every day. The machines are designed specifically for each customer so the outcome would be perfect.

Windak biggest customers are Commscope, Southwire and Nexans cable productions on several continents. Windak's customer is also the biggest cable manufacturer in Estonia, Keila Kaabel from Prysmian Group.

1.3 Windak OÜ work structure description

Windak OÜ manufacturing is project based as every order is treated as a separate project. The orders come in at the sales enquiry stage where sales ask input from engineers to offer the best solution for Windak and the customer. Since cables have a broad specification, machines need to be modified according to the customers required specifications. This description explains that Windak is using engineer to order (ETO) production approach. The main characteristics for ETO have been described as following [5]:

- the production of an ETO product is linked to an actual customer order with the decoupling point in the design stage;
- suitable for low volume, highly-customized production;
- requires order-specific engineering to some extent;
- shares many characteristics with the make to order (MTO) production.

To understand the main differences between engineer to order and make to order manufacturing a Venn diagram (Figure 1.4) is conducted. Make to order can sometimes be called build to order manufacturing.

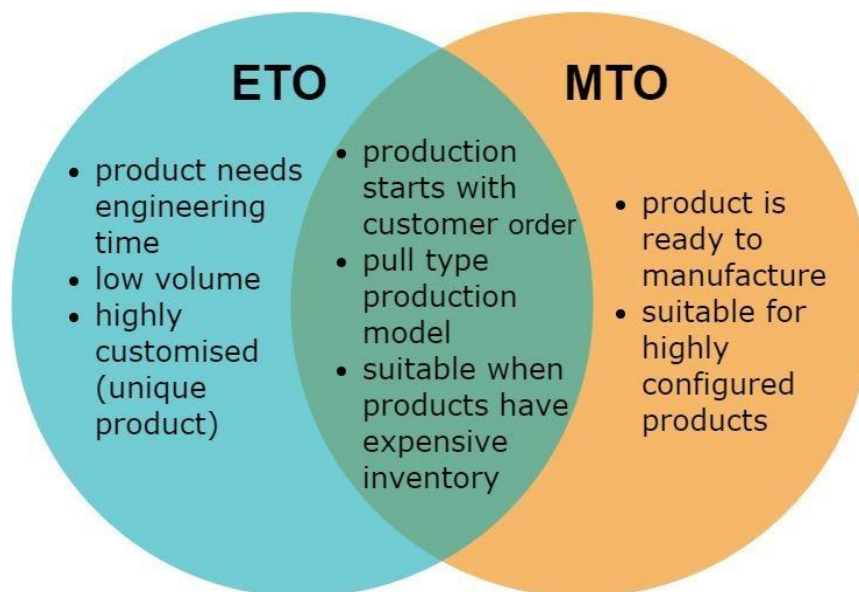

Figure 1.4 Similarities and differences between ETO and MTO

Windak OÜ company structure can be seen in Appendix 4. It is managed by the board of directors from Windak Holding (coloured green). Windak OÜ has a plant manager whose responsibility is to produce high quality products. Quality and financial managers are subordinates to plant managers, but they have great independence to

control their areas. Engineering, production, procurement and PLC programming managers are directly subordinates to plant manager. All the managers are coloured yellow. Each of the managers has its own department and the departments are divided into sub-departments. Each sub-department has one to several people working there. Project management position is located under administration.

Windak workflow (Figure 1.5) starts with sales processes that are managed by Windak Group's other companies. It is not uncommon for Windak that a customer is the one who proposes a new idea of what the machine should do. If a new project has acceptance from the board then it will be sent to the design and engineering department who will work closely with the sales department to design a machine acceptable for the customer. When most of the design is ready, the procurement process starts. Eventually an assembly process starts. After the assembly process is complete, testing will be done. Packing steps will be performed before transport.

Transport criteria differ from customer to customer, but Windak always needs to make sure that the parcels are shipped according to Windak manual. When the machines have reached to the customer an installation crew sets up the machine at the customer's site. Set-up time can be from two weeks to a month and it includes training for customer's employees. Once the machine is set up and running, after service is offered to the customer. Since there are machines that work 24/7, maintenance is important for prolonging lifetime for the machines.

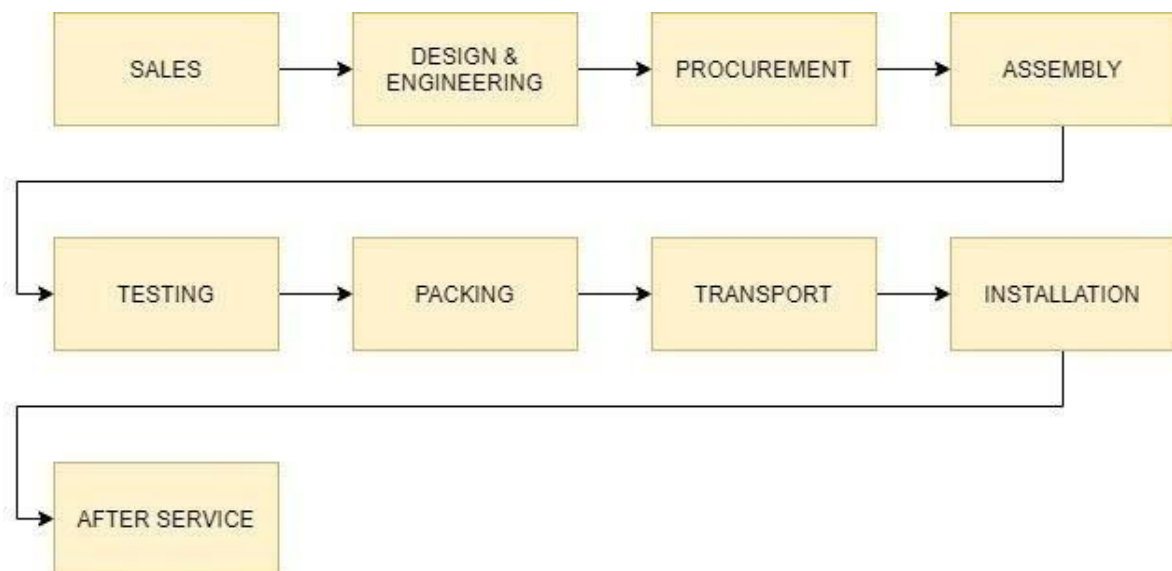

Figure 1.5 Windak OÜ workflow

With each line being different it is difficult to analyse the processes as mass production. Since the activities are similar with each project, the production analysis will be divided into different activities based on the production process diagram. Figure 1.6 depicts from procurement end to the end of packing for transport.

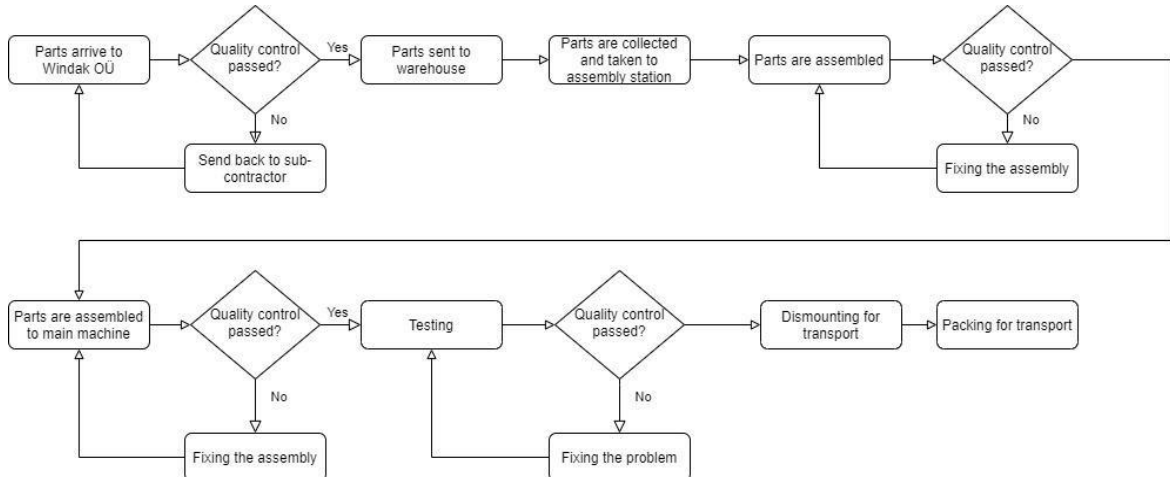

Figure 1.6 Detailed process from parts arriving to packing

To analyse the production processes of Windak OÜ the processes are chosen from the diagram with some processes expanded while others are disregarded. For example testing is not analysed, because the length varies. Following processes are going to be used for analysis:

- Warehouse intake;
- Quality control;
- Locating parts to warehouse;
- Warehouse collecting parts;
- Mechanical assembly at workstation;
- Mechanical assembly on a machine.

Windak OÜ has ISO9001:2015 standard for quality management. The Figure 1.5 and Figure 1.6 have been depicted according to ISO procedures described in Windak OÜ Quality manual. [4]

1.4 Overview of the current production

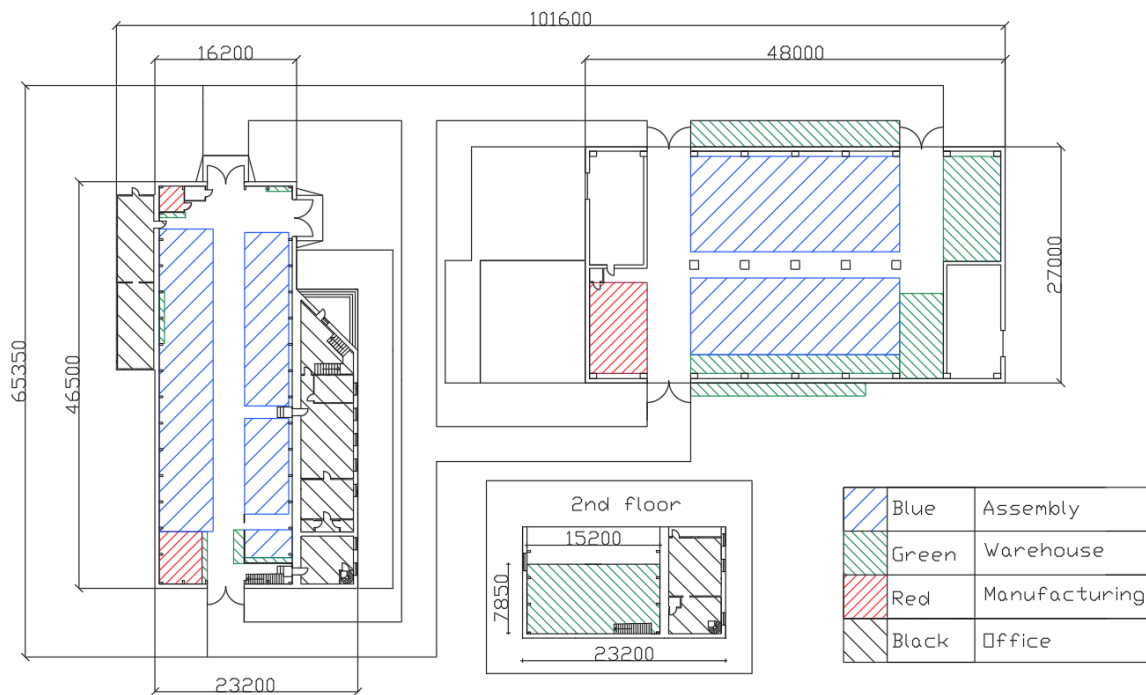

Figure 1.7 Old factory areas

Prior to the relocation, Windak OÜ factory layout are described in graphical materials on drawings with file name Old1, Old2 and Old3. The areas are depicted in Figure 1.7 and in the graphical materials on a drawing with file name Old4 with two production buildings with a total area of 2140 m². 1100 m² is owned by Windak and 1040 m² is rental property. The rental property is located 40 meters from the Windak building. It must be noted that 1040 m² is the total area of the rented building, but the total usable space is less, since the support beams in the middle of the manufacturing area and uneven floors in some places lose as much as 80 m² of usable space.

Table 1.1 Area of the old production facilities

Facility	Total (m ²)	Assembly (m ²)	Manufacturing (m ²)	Warehouse (m ²)	Office (m ²)	Other (m ²)
Old factory	1100	374	36	120	280	-
Rented factory	1040	473	61	165 + 100 outside	0	80 not operatable
Total	2140	847	97	285 + 100	280	80 not operatable

Windak production area can be divided into three sections: assembly, manufacturing and warehousing. Each section is described further in the following Items 1.4.1, 1.4.2 and 1.4.3. Table 1.1 depicts precise measurements for these areas. Production area includes assembly and manufacturing area.

1.4.1 Overview of the assembly area

Historically the machines are assembled in the one location from beginning to end. Staff working on the assembly either work on the machine or at movable workstations. Movable workstations are used for smaller sub-assemblies. On the machine assembly means that the first thing that is done is to position the main frames of each machine precisely how they are positioned on the final layout and then details are added to the main frame.

The same assembly area is also used for testing. The machines can be tested once the assembly is in final stages. When the machines are ready for testing, the assembly crew leaves the site and the testing crew comes and starts testing on the same site. This has caused time loss for testing, as sometimes testers are scheduled to start with one machine, but assembly hasn't finished in that area.

Prior to relocation Windak has room for 4 full lines at the assembly area. The total assembly area is 374 m² in the main building and 473 m² in the rented property.

1.4.2 Overview of the manufacturing area

The manufacturing area is in the Windak owned factory, since the manufacturing machines need a stable environment with high quality flooring. Also the internet connection and controlled indoor climate play an important role with milling and turning machines.

The metal processing area machines are depicted in the Table 1.2. It has a CNC Lathe and a Mill as main equipment and also a metal saw, welding unit, magnetic and stationary drill. Windak OÜ established a manufacturing

area to control the quality and reduce lead times on complicated details. Controlled environment helps to ensure the desired result.

The manufacturing area is 200 m² in the main building. For the drilling and milling machine a floor was renovated to ensure the required accuracy.

Table 1.2 Manufacturing machines at Windak OÜ

Equipment	Model	Manufacturer	Year
Turning	DNM500	Doosan	2019
Milling	Quickturn Compact 200MYL – SmoothC	Mazak	2018
Saw	Mercury	FMB	2018
Magnet drill	Bux BRP 50	Walker Magnetics	2010
Drill	25 df3	RACE	2010

1.4.3 Overview of the warehouse area

Warehouse purpose can be divided into two: warehouse for assembly parts and warehouse for the test material. Windak machines need a lot of testing with customer materials, because the machines are produced according to customer specific needs. Therefore customers ship a lot of materials from cable samples to blank labels. On average, one customer ships half a 40' sea container full of test materials to Windak factory. To reduce the cost, our sales company in the USA, Windak Inc., consolidates the test materials from different customers and ships them together.

The Windak production site usually has test materials from 3-4 customers. One sea container has 29,28 m² floor space and the material is stacked, then it is usually calculated that a container full of material needs floor space of approximately 30 m² and with 3-4 customers up to 120 m² floor space in the warehouse is needed. If the stationary test material from older projects is also calculated, then area of 200 m² is needed for it. Since most parts of test material are weather-proof it can be stored outside also. Right now Windak has 129 m² for assembly parts and 165 m² for test material, with extra 100 m² outside storage.

1.4.4 Problems in the current production

The plan of moving is not only to give personnel better working conditions but also to reduce problems that Windak OÜ is having previously.

One of the goals is to have a flexible production facility. That means if a company decides to change their product it will be possible to change production according to the new needs. Today's society is rapidly changing and flexibility is welcomed in every aspect of life.

The second main problem is that the workers need to move between workstations and manufacturing areas to reach their destination, producing waste in motion and therefore increasing idle time and loss in productivity. This problem has emerged with time, since the company has expanded their manufacturing site gradually.

Third and most apparent problem is that the manufacturing and assembly floor space needs to be more spacious. One way to reduce the lack of space is well thought placement of each part, but since the lines that Windak produces are from 40 -120 m² big, the space is needed for the ready set-up only.

The overall goal of moving is to have well planned factory with state of the art technology and motivated people to work with the equipment.

1.5 Main reasons for relocating the factory

As was mentioned in previous chapters, there are four reasons for Windak OÜ moving to a new factory:

The primary reason for the relocation is that there has been an increase in sales and therefore, larger manufacturing capacity is required. Physically bigger areas are not always a solution that removes problems that appear in small production areas. Bigger area can lead to more chaos in production. Therefore, one of the goals is to analyse and think through how the new layout for the production hall will be designed to maximize the efficiency and minimize waste.

Second reason is that Windak OÜ is in the process of increasing the amount of details made on site with milling or turning machines. As previously mentioned, Windak has a goal to increase products made in house and therefore, it needs more machines to meet this objective. More details and machines need more space.

Third reason is that Windak Group needs a presentable showroom for the customers. Since travelling is more popular each year, the trend of customers and vendors visits to Windak OÜ has increased over the years. It is custom in Windak that customers visit the showroom before purchasing a new line or accepting a line that is ready to be shipped out from the factory. Therefore an area for customers is planned for the new factory.

The fourth reason is that the job market in Estonia had only 3,9% of unemployment in third quarter of 2019 and therefore it is crucial to present modern working conditions for the workers both in the office and in the production halls. [6] With the new building there will be increased office space for office workers and better facilities for all personnel like restrooms and lounges where workers can rest and spend time with recreational activities like working out or playing games.

In conclusion, the relocation will enable Windak to complete more work in a more efficient way, but it will be more than just moving from one building to another. For Windak it will be changing the culture of the workplace by enabling workers to have space and means for resting and relaxing.

2 THEORETICAL BACKGROUND

The global spread of production makes companies relocate their manufacturing units frequently. [7] This can mean different things:

- The company changes their location, where the change is within an area that doesn't affect employees', contractors' or subcontractors' behaviour towards the company. In that case the operations know-how, stays with the company.
- The company changes their location, where the changes affect employees', contractors' or subcontractors' behaviour and they are forced to change the behaviour towards the company by ending the contracts or reducing co-operation. In that case the know-how must be transferred to the new stakeholders.
- The company relocates only part of their production. In that case the know-how stays in the company, but also needs to be transferred to a new location.

This thesis analyses a relocation project, where the company moves 20 km from the existing location. The relocation takes place within an area that should not have a large impact on the employees, contractors and subcontractors, nor will it affect their behaviour towards the company.

The theoretical part of the thesis will analyse different moving strategies, how to plan the relocation project, manufacturing methods for the new factory and how to measure the changes between prior and new set-up.

2.1 Different moving strategies

Studies have shown that relocation decisions are most commonly motivated by location and labour considerations. [8] Window OÜ is a subsidiary of the Windak Group which chose the location of its only manufacturing company based on the proximity to Sweden, where the company was established and because of the cost effective workforce that Estonia had at the beginning of 21st century. Since then, the global workforce and manufacturing environment has changed dramatically so the company had to decide what to do with Windak OÜ.

Based on Kasra Ferdows classification of foreign factories, Windak OÜ can be described as a “lead factory”. Windak OÜ has the ability to create new processes, products, and technologies for the entire company. It uses local skilled workforce and technological resources to develop products and processes. The company managers can choose suppliers and participate in development projects. [9]

Due to Windak Group increasing its yearly turnover, a new strategy was needed for the whole company. Two strategic options stood out:

- Moving closer to the customers
- Expand the current production centre

Table 2.1 Main Advantages and disadvantages for different strategic options

Criteria	Moving closer to the customers	Expand the current production centre
Advantages	Closer to the customer; better after service	No need for knowledge transfer; all the development, procurement and assembly know-how on site
Disadvantages	Bigger labour cost; need to transfer knowhow about assembly, procurement and development; need to build up new supplier system	Labour shortage; limited scope for development due to the size of the country, no customers in Estonia and main customers are in US

After the analyses based on advantages and disadvantages brought out in Table 2.1 it was determined that the relocation will take place and the Windak OÜ factory will be moved to Peetri, Harjumaa. Primary advantages for the location are closeness to the harbour and airport.

2.2 Planning the factory relocation

In a development project, the cost for design changes is exponentially related to the development phase (seen in Figure 2.1). A relocation project can also be considered a development project since the project is a onetime project without any previous experience and requires design and analyses. The planning stage is crucial for a relocation project. A good relocation plan can cut the cost of the project by saving time and resources.

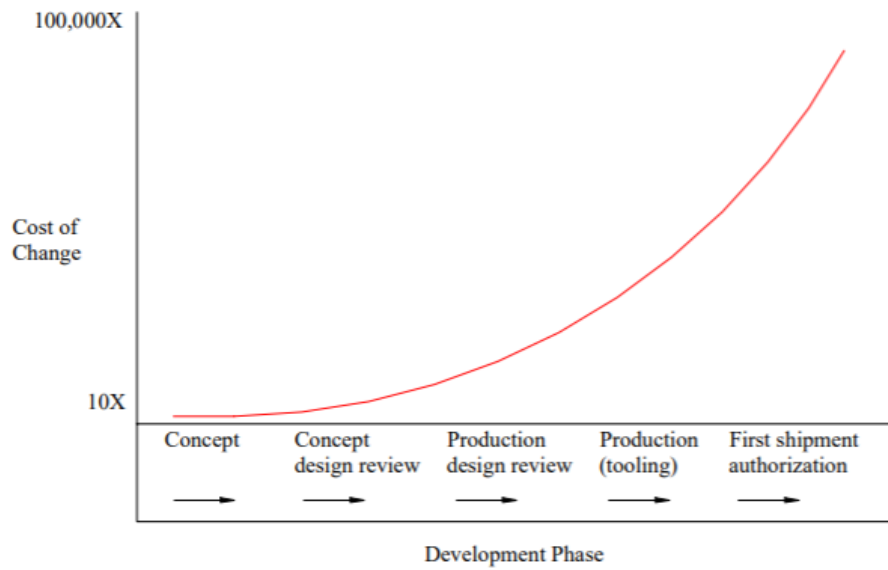

Figure 2.1 Cost for design changes [10]

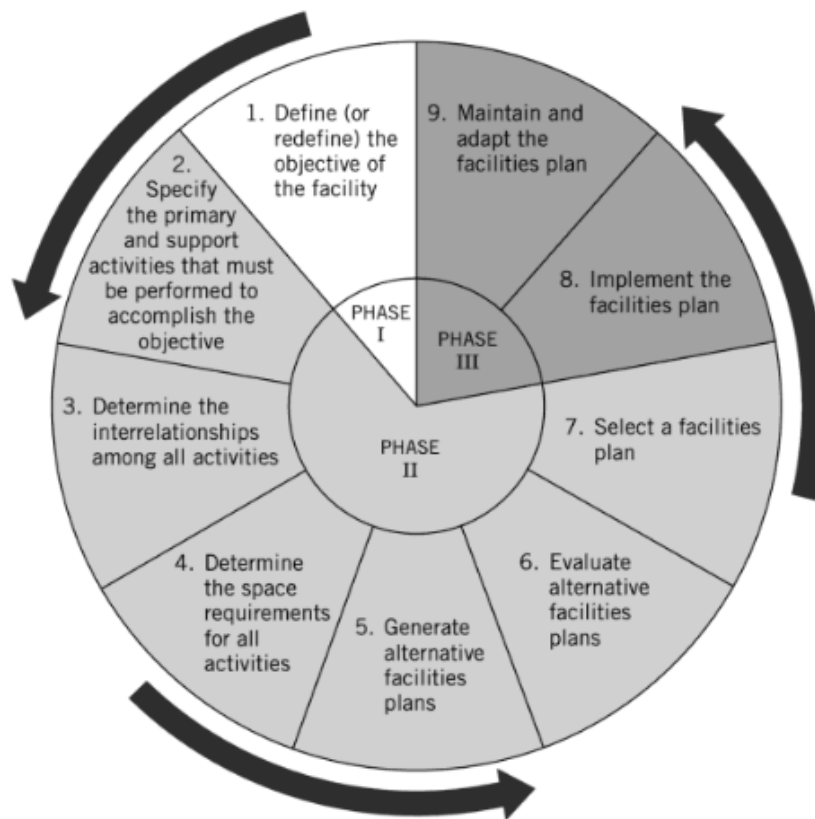

Figure 2.2 The planning process for manufacturing facilities [11]

Inadequate planning of the layout can increase total costs 15% to 70%. [11] To have a great layout for the new factory, an overall relocation plan needs to be draught. The relocation plan that the author is suggesting in Chapter 6 for Windak OÜ is a modification of the facility planning processes from the book "Facility planning". [11]

The process indicates three phases (Figure 2.2) with the first one being defining the objectives. Second phase consists of specifying the activities, determining the tasks for each team member and selecting the final plan from several alternatives. Third phase is implementing and maintaining the new changes.

2.2.1 Transferring the property

The company property needs to be transferred regardless of why the relocating takes place. Property can be divided into two categories: knowledge and equipment (including personnel).

Knowledge is mainly gathered and stored in personnel or in digital devices. Knowledge in digital devices will be transferred with other equipment. In case of the Windak OÜ relocation, a knowledge transfer is not applicable, as the move will be within the same district of Harjumaa and the distance between two facilities, the old and new one, will be approximately 17,5 km by road. If there is going to be employees that will be changing their job due to the moving, the knowledge transfer will be managed by their direct supervisor.

On the other hand transferring equipment is one of the biggest challenges of the relocation. Windak makes project based machines that take 1-3 months to complete assembly and testing, so, to minimise the potential for any delays, the process of moving the assemblies and Windak OÜ's own equipment has to be well planned. Main problem will be planning the state of the machines in production and achieving the state for the time of the moving so that the minimum amount of mounting and quickest set-up at the new factory could be managed. Also, one goal of the relocation is to increase the work ethic and make the workplace more productive and the teamwork stronger between different departments.

2.3 Lean manufacturing method to identify the waste

Windak OÜ has made a decision to improve all the aspects of their business, not only changing a building where they were located. LEAN principles are chosen as an example to guide the changes that need to be carried out. This section describes the LEAN principles that Windak OÜ plan to integrate. Also, directions on how they can be integrated to a production company are given.

Lean manufacturing can be defined as a business system and a generic process management philosophy with a systematic approach to eliminating waste through continuous improvement. [12] Lean or Lean thinking is based on the Japanese quality movement, specifically, the Toyota Production System (TPS). Manufacturing with Lean in mind has certain features such as reduced lead times of processes, faster delivery, improved quality of end products, reduction in inventory such as the work in process (WIP), low customer service activities, core materials, and products at all customer interfaces. [13] Simply said the goal of LEAN is to reduce all types of waste.

Classification of waste sources includes the following categories: transport, inventory, motion, waiting, overproduction, over-processing, defects, skills (TIMWOODS). [14] TIMWOODS wastes are described by McGraw and Hill in their book "The Toyota Way" more thoroughly and depicted in Table 2.2.

Table 2.2 8 types of waste in production [15]

Waste type	Description	Consequence
TRANSPORT	Transporting WIP (work in progress) long distances, creating inefficient transport, or moving materials, parts, or finished goods into or out of storage or between processes.	Longer process and lead times, extra work time, transportation and storage costs, and delay
INVENTORY	Excess raw material, WIP, or finished goods. Extra inventory can hide problems such as production imbalances, late deliveries from suppliers, defects, equipment downtime, and long setup times.	Longer lead times, obsolescence, damaged goods, transportation and storage costs, and delay
MOTION	Any wasted motion employees have to perform during the course of their work, such as looking for, reaching for, or stacking parts, tools, etc. Also, walking is waste.	Longer lead times, longer work time
WAITING	Workers serving to watch an automated machine or have to wait for the next processing step, tool, supply, part, etc., or just plain having no work because of stock outs, lot processing delays, equipment downtime, and capacity bottlenecks.	Longer lead times, longer work time
OVER-	Producing items without orders. Creating excess	Overstaffing, higher

Waste type	Description	Consequence
PRODUCTION	inventory.	storage and transportation costs
OVER-PROCESSING	Taking unneeded steps to process the parts. Inefficiently processing due to poor tool and product design, causing unnecessary motion and producing defects. Waste is generated when providing higher-quality products than is necessary.	Longer lead times, longer work time, higher product cost
DEFECTS	Production of defective parts or correction. Repair or rework, scrap, replacement production, and inspection means wasteful handling, time, and effort.	Longer lead times, longer work time, higher product cost
SKILLS	Unused employee creativity. Not engaging or listening to your employees.	Losing time, ideas, skills, improvements, and learning opportunities

2.4 Key performance indicators to measure the performance

A performance indicator can be defined as an item of information collected at regular intervals to track the performance of a system. [16] Key performance indicators (KPIs) are chosen by the company as the most important indicators that the individual or project is going to achieve the intended goal. To analyse whether the relocation has been a successful project KPIs are measured and analysed.

To facilitate the goal of relocating a factory, the KPIs in this thesis are grouped into following key business perspectives that are shared across most organisations, irrespective of type or industry sector [17]:

- Financial perspective;
- Customer perspective;
- Marketing and sales perspective;
- Operational processes and supply chain perspective;
- Employee perspective;
- Corporate social responsibility perspective.

KPIs measure the business health of the enterprise and ensure that all individuals at all levels are working towards the same goals and strategies. [18] In an effort to lessen the complications associated with KPI selection, the organisation should consider the following principles while selecting or defining new indicators [19]:

- An indicator must motivate the right behaviour
- A KPI must be measurable
- A KPI must be affordable
- The objective set for a KPI must be attainable
- Factors affecting the indicator must be controllable by the service provider
- A KPI must be meaningful to all the parties.

3 WINDAK OÜ OLD FACTORY PRODUCTION FLOW ANALYSES

In this chapter the main production processes at the old factory are described and analysed. The goal is to improve Windak OÜ production when relocating the factory. Windak OÜ moved to its current location in 2004 when the company was established. At first the office, recreational and production area all fitted in the main production hall. Later with the growth of the company bigger offices and recreational areas were built and removed from the hall. Old factory has a process based layout since Windak produces a variety of products in small quantities, requires high flexibility in production and the workers are experts in Windak production. [20]

To analyse the weaknesses of the old factory and plan the new factory, a process flow analysis is conducted in AutoCAD that depict the distance travelled and time required to complete each step. The processes are standardised and described in the process activity chart. Steps from part arriving until the end of assembly are measured and described to identify the processes that must be changed in the new factory layout. The main focus of this thesis is to eliminate transport and motion waste to save time in the overall process. As it can be seen from the process activity chart, time and distance is measured and value code is added for each task to determine whether it is value adding, non-value adding or required activity.

Products are chosen based on the nature of Windak OÜ production depicted in Figure 3.1. Prior to the relocation, Windak OÜ's main responsibility is assembling sub-contracted parts and a small proportion of parts manufactured on site. The goal is to reduce sub-contracted parts and manufacture primarily on site. Consumables are not analysed, because there is no precise overview of their inventory at the old factory. Three different part types are analysed based on current works:

- Sub-contracted parts based on the drawings made by Windak OÜ;
- Locally manufactured parts based on the drawings made by Windak OÜ;
- Subcontracted standard parts.

The parts that will be analysed are part of one assembly. Each category part is analysed separately (except consumables, since they are ordered in bulk and seldom cause any problems with the warehouse and also they act similar way with off the shelf parts). After each part is analysed the assembly will also be analysed.

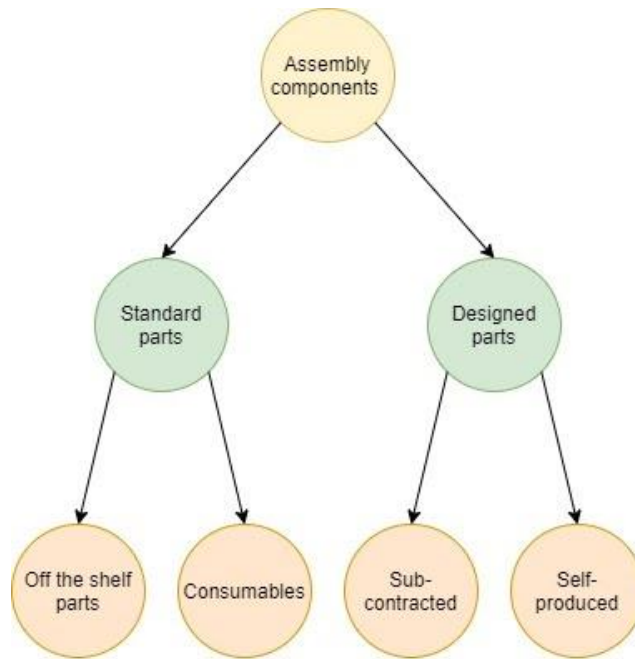

Figure 3.1 Assembly components

3.1 Overview of the old production flow based on assembly 02-4005-B2

Table 3.1 Assembly 02-4005-B2 main parameters

Name	02-4005-B2	Off the shelf	9
Weight	28 kg	Consumables	15
Dimensions	314 x 355 x 1305 mm	Subcontracted	14
Assembly time	58 min	Self-produced	1
Material	S235, Al, other	Total parts	39 different parts 60 parts total

Assembly 02-4005-B2 main parameters are described in Table 3.1. It is a length counter that is used for measuring the cable length to ensure the correct lengths are in each coil/spool. The assembly is designed by Windak mechanical designers and it consists of designed parts and standard parts. Since the assembly is part of a main machine it is not sold separately. The length counter was chosen because it has been

made more than twice and it has all the different categories of parts in its assembly. The assembly code 02-4005-B2 meaning is described in Table 3.2.

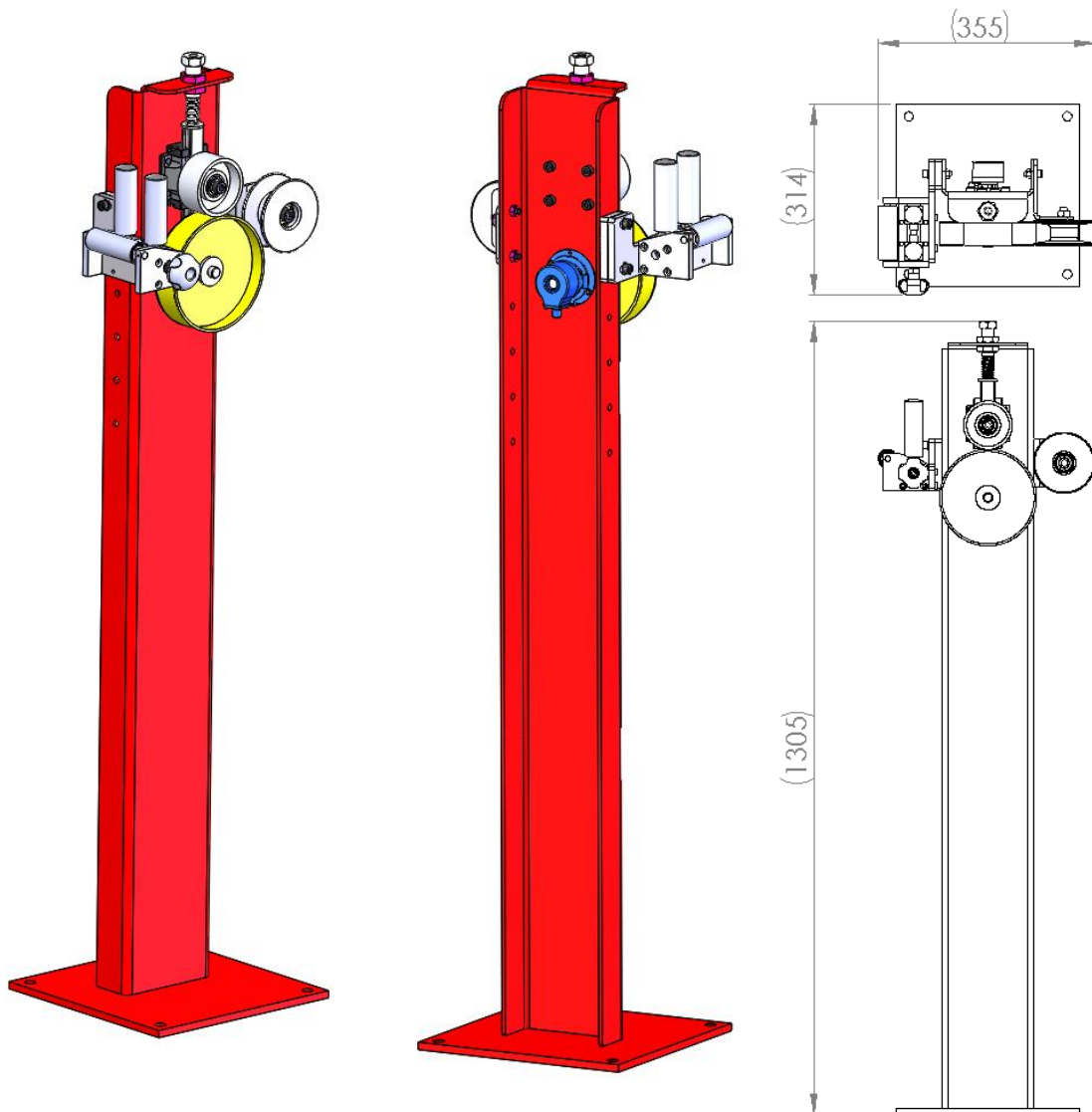

Figure 3.2 Windak length counter 02-4005-B2

Table 3.2 Assembly code descriptions

02	-4005-	B	2
Mechanical assembly code	Consecutive number	Right-to-left line direction	Version

The assembly has 39 different parts and 60 parts overall. 9 different parts are off the shelf standard parts, 15 are consumables (mainly fasteners), 14 details are subcontracted and 1 detail is self-produced. BOM list can be seen in the Appendix 2. The meaning of the part numbers is described in the Appendix 1. To analyse different flows three details are chosen, coloured yellow, red and blue on the Figure 3.2.

Position 010 in the BOM list (part no. 20-078729-1, coloured red), 080 (part no. 81-000345, coloured blue) and 120 (part no. 20-022000, coloured yellow) are analysed. The total assembly time for the assembly workers to finish the length counter is 58 min. Length counters are assembled on a separate moving assembly table. Each mechanic has his own table where he keeps all the tools needed for basic assembly. All the fasteners are in the far corner of the factory and this is the greatest time loss when moving around the assembly table. All the details needed for the assembly (except fasteners) are stored in the warehouse and transported from there by a warehouse worker. Warehouse worker has previously gathered all the details in a transport box and takes the box to the main machine assembly area. A mechanic can find the box there and start to assemble. When the assembly is finished it will be mounted to the main machine. For part flow analyses the parts collecting at warehouse, transport, assembly time and quality check time is taken into account. Figure 3.3 shows flows for different parts. A drawing in the graphical materials with a file name Old5 depicts the flows more precise.

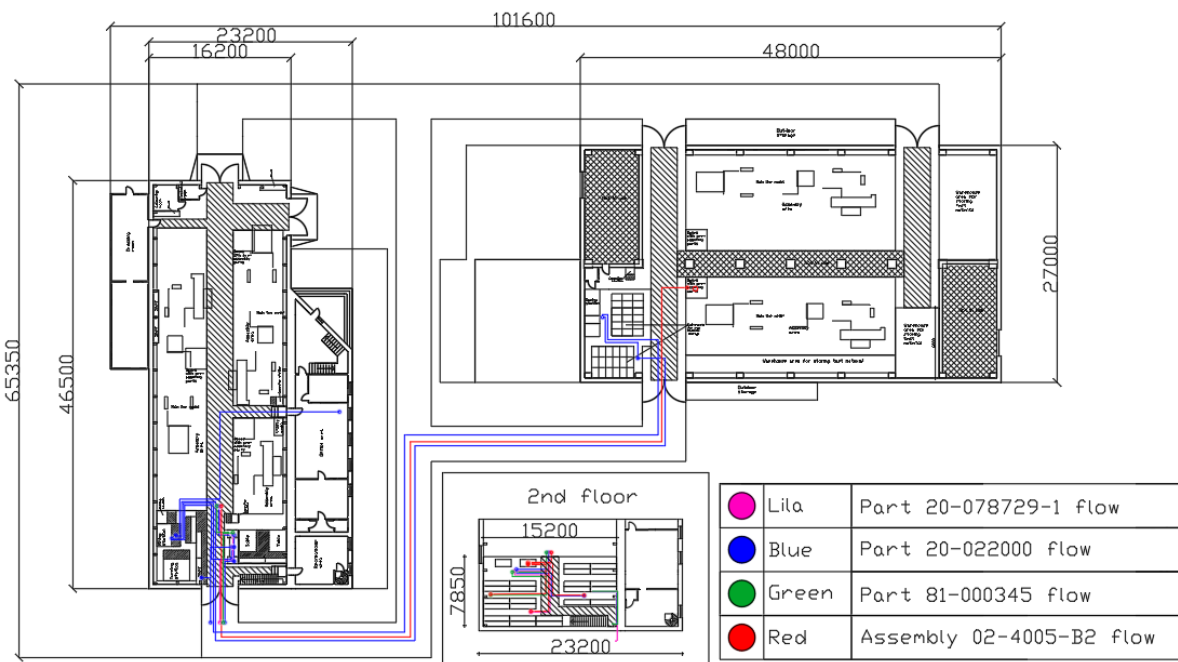

Figure 3.3 Diffeernt part flows in the old factory

The flows are analysed by studying two stages. First stage is described in items 3.1.1, 3.1.2 and 3.1.3 and the second stage is described in Item 3.1.4.

- First stage is parts from arriving (or ordering the manufactured parts) until they reach to the warehouse;
- Second stage is assembly from gathering at the warehouse to giving the gathered assembly to assembly workers.

3.1.1 Designed subcontracted part 20-078729-1 flow

Table 3.3 Part 20-078729-1 main parameters

Name	20-078729-1
Weight	19200 g
Dimensions	300 x 300 x 1270 mm
Material	S235

Detail 20-078729-1 main parameters are described in the Table 3.3 and sketch in the Figure 3.4. It is designed at Windak OÜ and purchased from a subcontractor. All the details that Windak doesn't have capacity or technology to produce are subcontracted. In this case, Windak OÜ does not carry out welding processes. No parts that require welding jigs are manufactured at Windak OÜ. Part 20-078729-1 is a stand for length counter assembly. The stand can be different for each project. 20-078729-1 was chosen, because this type of part is frequently needed. Table 3.4 describes the part flow.

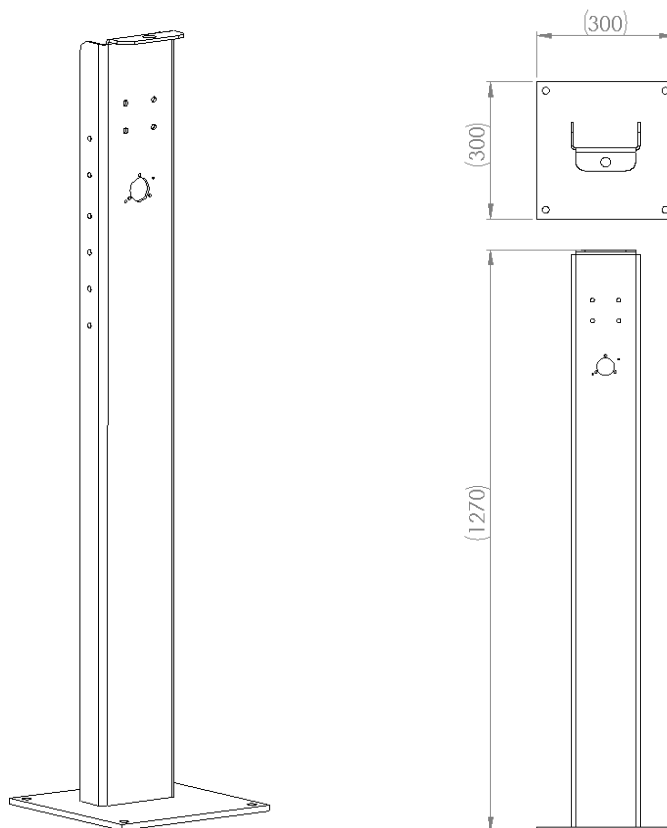

Figure 3.4 Part 20-078729-1 sketches

Table 3.4 Part 20-078729-1 flow in the old factory

No	Description	Time	Distance	Value Code
	Part no. 20-078729-1. Designed by Windak OÜ, subcontracted parts	(min)	(m)	(V/N/R)
1	Package is delivered and signed for, drawing is placed to the incoming folder	1,2	17	V
2	Package waits in the inbox to be checked by quality	45	0	N
3	Quality unwraps the package	0,5	3	N
4	Quality checking	7	0	N
5	Placing the part to the "Checked" tray, drawing is placed to the "checked" folder	0,3	3	N
6	Waiting for warehouse worker to pick the tray	60	0	N
7	Warehouse worker transports the tray to the warehouse	3,5	79	N
8	Warehouse worker inserts the part to the system	0,5	2	N
9	Warehouse worker places the item to the correct shelf	0,75	30	N
10	Waiting	7296	0	N
	Total	7414,75	134	

From the time the part arrives until the end position the total time is 7414,75 minutes (15,4 workdays). The most time consuming activities are related to waiting. The longest period is the part waiting on the shelf in the warehouse with an average of 7296 minutes (15,2 workdays), the second is waiting for the warehouse worker to collect the "checked" tray with 60 min (1 hour) and third is also waiting at the inbox to be checked for 45 minutes. Since the waiting is caused due to procurement processes they are not analysed as thoroughly since the goal of this thesis is to analyse the layout and to carry out improvements on it. The part covers a journey of 134 meters to reach to the warehouse. The longest distance with 79 meters is transport between the quality checking station and the warehouse. It can be seen that some changes need to be thought of regarding warehouse work and/or location.

3.1.2 Designed self-produced part 20-022000

Table 3.5 Part 20-022000 main parameters

Name	20-022000
Weight	445 g
Dimensions	Ø159 x 40 mm
Producing time	7 min/pcs
Material	Al

Part 20-022000 main parameters are in the Table 3.5 and sketch in the Figure 3.5. It is designed and manufactured at Windak OÜ. Windak has one milling and one turning machine. The products are based on the cost, delivery time, blank material requirement and volume. All the surface treatment is completed by subcontractors. Detail 20-022000 is chosen because it has a high production volume by Windak standards. Typically a minimum of 20 pcs are produced at once. For the detail to be produced by Windak OÜ the subcontractors' data will be left empty in the ERP system. That way a production planner prints the drawing and puts the drawing in a folder next to the applicable machine (milling or turning). The folder is arranged by the due dates. The operator takes the drawing and goes to the raw material warehouse to saw a correct piece out for the part from the blank. After sawing he completes the remaining work on the part. After the part is machined it goes to the quality check. If the part needs surface treatment, then the quality controller sends it to the subcontractor. After arriving back from the subcontractor the part is handled further like the subcontracted part. It takes 7 min each to produce 20 pieces. Part 20-022000 is a support in the length counter to the cable that runs through the machine. Therefore the wheel needs to be precise and high quality. Table 3.6 describes the part flow in the old factory.

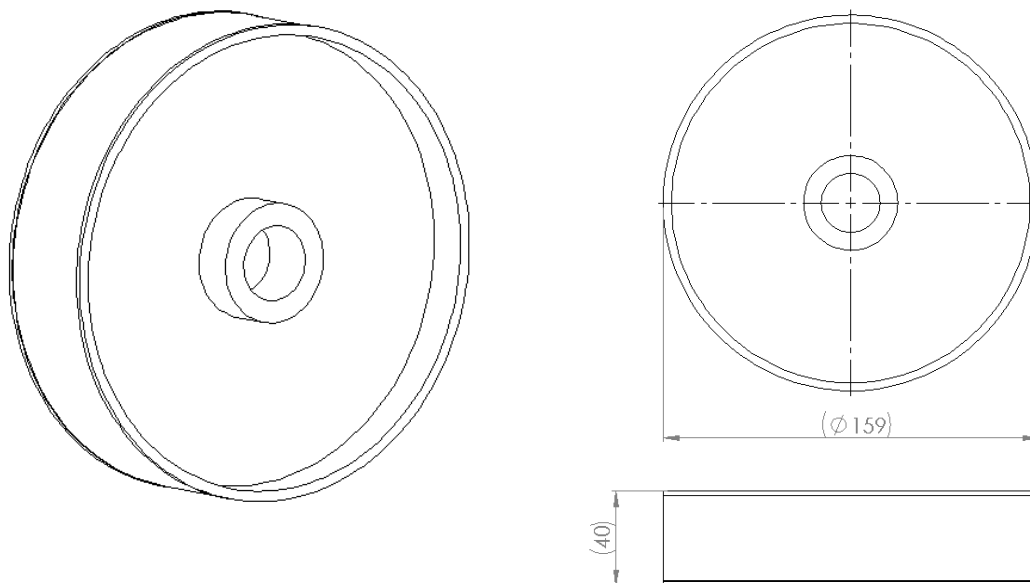

Figure 3.5 Part 20-022000 sketches

Table 3.6 Part 20-022000 flow in the old factory

No	Description	Time	Distance	Value Code
	Part no. 20-022000. Designed by Windak, self-produced parts	(min)	(m)	(V/N/R)
1	Production planner brings an order drawing to the operator	4	65	N
2	Operator goes to warehouse	7	123	N
3	Operator prepares the blanks	34	20	N
4	Operator brings the blanks to the workstation	9	123	N
5	Operator manufactures the order	7	4	V
6	Operator places the order at the quality checking inbox	1	1	N
7	Package waits in the inbox to be checked by quality	45	0	N
8	Quality checking	7	0	N
9	Quality sends the part to subcontractor for surface treatment	12	10	R
11	Package is delivered and signed for, drawing is placed to the incoming folder	2	17	V
12	Package waits in the inbox to be checked by quality	45	0	N
13	Quality unwraps the package	0,5	3	N
14	Quality checking	7	0	N
15	Placing the part to the "Checked" tray, drawing is placed to the "checked" folder	0,3	3	N
16	Waiting for warehouse worker to pick the tray	60	0	N
17	Warehouse worker transports the tray to the warehouse	3,5	79	N
18	Warehouse worker inserts the part to the system	0,5	2	N
19	Warehouse worker places the item to the correct shelf	0,75	30	N
20	Waiting	5904	0	N
	Total	6149,55	480	

People cover a total journey of 480 meters from giving the order to part placed to the warehouse. The longest distance of 123 meters is between a manufacturing area and the blanks warehouse, where the operator goes to cut out the blanks used in manufacturing. Also the same distance is needed to go back to the manufacturing area. Second longest distance with 79 meters is transport between the quality checking station and the warehouse. Third is the distance a production planner needs to walk to give the manufacturing order to the operator. From these results it can be seen that relocating a blanks warehouse can be the first change to implement. Also the process of receiving a manufacturing order could be done by computer.

The most time consuming activities are related to waiting as previously. But also the preparing of blanks takes a lot of time due to bad location and slow information flow (not enough orders are given at once).

3.1.3 Purchased standard part 81-000345 flow

Table 3.7 Part 81-000345 main parameters

Name	81-000345
Weight	500 g
Dimensions	Ø370 x 50
Material	Steel, other

Standard parts are parts that Windak OÜ can buy off the shelf from suppliers. Mainly these are electrics, pneumatics, fastenings and standard machine elements. Part 81-000345 main parameters are described in the Table 3.7 and picture of the part is in the Figure 3.6. It is an encoder that was chosen because it is one part of the length counter. Encoders are used in length counters to convert rotatory motion into digital signals to control the speed and time. This device gives the correct length of the cable passing the equipment. The part flow is described in the Table 3.8.



Figure 3.6 Part 81-000345 product picture [21]

Table 3.8 Part 81-000345 flow in the old factory

No.	Description	Time (min)	Distance (m)	Value Code (V/N/R)
	Standard parts, off the shelf parts			
1	Package is delivered and signed for	1,6	15	V
2	Package waits in the inbox to be handled by warehouse	45	0	N
3	Warehouse empties the tray and takes it to the warehouse	3,5	79	N
4	Warehouse checking of the order and a part	4	2	N
5	Warehouse worker inserts the part to the system	0,5	2	N
6	Warehouse worker places the item to the correct shelf	0,75	30	N
7	Waiting	8880	0	N
	Total	8935,35	128	

From the time the part arrives until the final position the most time consuming activities are related to waiting and longest distance is transport to the warehouse, like the previous parts. Waiting time for the encoder is the longest with 8880 minutes (18,5 workdays) the average due to ordering in bulk. The time between arriving and ending up in the warehouse is 55,35 minutes and the distance is 128 meters. The total part handling time is 8935,35 minutes (18,6 workdays).

3.1.4 Assembly 02-4005-B2 flow

Assembly 02-4005-B2 flow is described in the Table 3.9.

Table 3.9 Assembly 02-4005-B5 old flow

No.	Description	Time	Distance	Value Code
	Assembly 02-4005-B2 Length counter	(min)	(m)	(V/N/R)
1	Warehouse worker gets an order to gather an assembly	2	0	N
2	Warehouse worker gathers assembly into a box	9	70	N
3	Warehouse worker transports the box to the main machine assembly area	9,1	204	N
4	Mechanic walks to the computer to start the job in the ERP system	1	10	N
5	Mechanic takes the box and transports it to his assembly desk	0,5	26	N
6	Mechanic gathers all the fasteners that is needed	4	16	N
7	Mechanic assembles the assembly	58	10	V
8	Supervisor comes and checks the quality of an assembly	4,3	50	N
9	Mechanic walks to the computer to finish the job in the ERP system and gets new work order to assemble the assembly to the main frame	2	26	N
10	Assembly is assembled to a main frame	12	20	R
11	Supervisor comes and checks the quality of an assembly	3	50	N
12	Mechanic walks to the computer to finish the job in the ERP system	0,5	26	N
13	Mechanics clean their area	35	60	N
	Total	140,4	568	

After the parts arrive to the warehouse a warehouse worker receives gathering order and starts to gather the assembly. From gathering to be given to the assembly worker the most time consuming activity is assembling process with 58 minutes and cleaning after assembly is mounted to the main machine with 35 minutes. These results describe that the author should look into previous processes and find a solution for improvement. Assembly process is the only value adding process in the table, so it can't be eliminated.

Longest distance of 204 meters is between the warehouse and an assembly area, because the arithmetical average is measured due to two assembly areas locating at the same factory and two in the rented factory. The second longest with 70 meters is at the warehouse when the worker gathers the assembly from the shelf to the box. The third longest is the distance an assembly worker walks when they clean their areas (60 meters). These results show that the layout with two facilities is not efficient and needs to be studied. Also the cleaning process for assembly workers needs to be more efficient.

4 WINDAK OÜ NEW FACTORY PRODUCTION FLOW ANALYSES

To plan the new factory the author used a top-down approach with two steps, where the first step was to divide the departments on the layout and the second step was to plan the department inside the given area. [22] Top-down approach was used because the input for the task of planning the new factory came from upper management and the reason was lack of space. If the reason for moving would have come from the employees not working efficiently then a bottom-up approach could have been one of the tools used.

The new factory layout is depicted in the drawing with file name New1 and it also is a process based layout, since the main idea of producing Windak machines stays the same. With the top-down approach, the first step in planning the factory was to determine how much space each department requires. This was calculated based on an old factory layout. Since the new factory is designed to be able to accommodate the growth of Windak in the future, bigger areas can be used at the moment. Some departments can be put together in the future since they are part of the same system and located near each other.

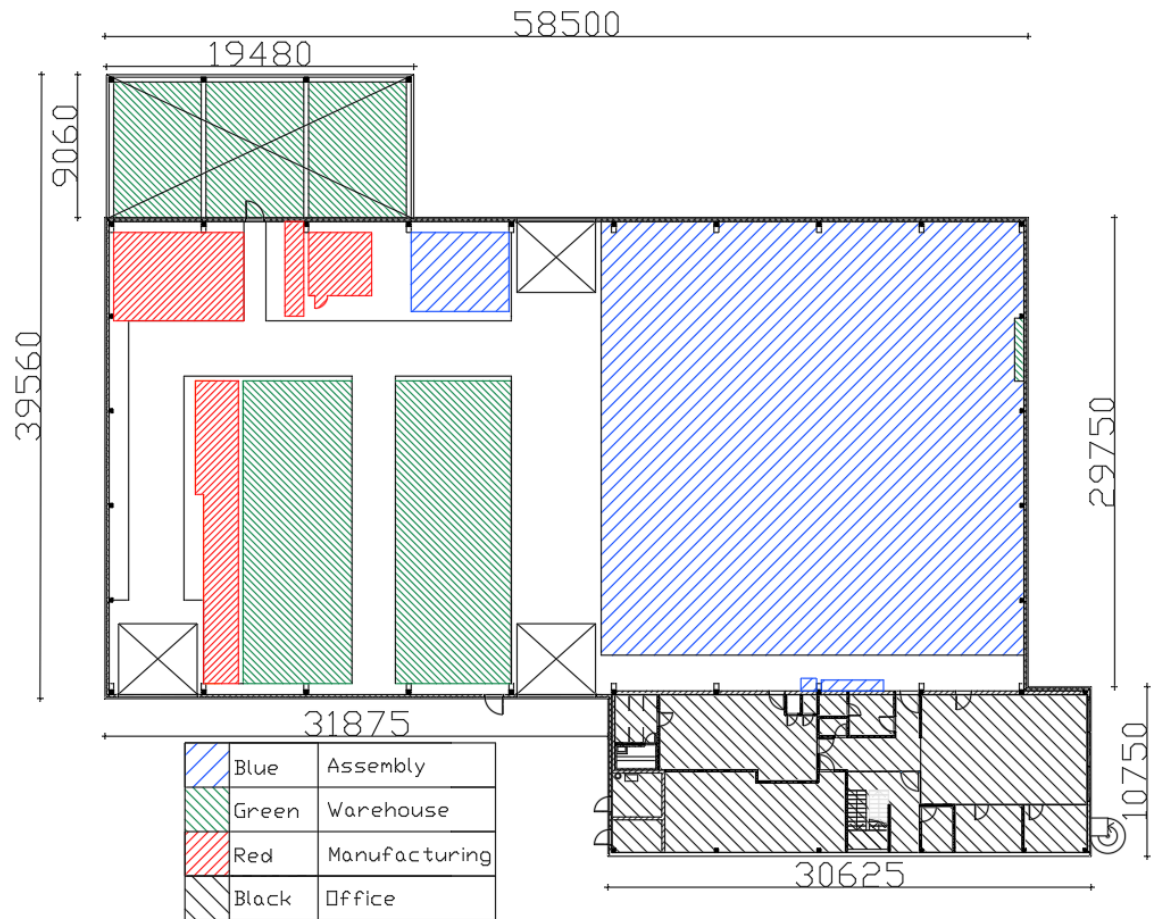

Figure 4.1 New factory areas

Second step for the planning was to determine where each department should be located so that the flow of the production would be as smooth as possible. This is achieved with different layout drawings made in AutoCAD and analysing the detail movements by experimentation. The distances are compared with the old factory and the best solution is chosen. Third step is to plan each department based on its specific needs and overall flow. After planning and comparing different opportunities a final layout is presented in Figure 4.1 with areas described in the Table 4.1. Also a drawing with file name New2 can be found among the graphical materials. Workflow descriptions for three parts are also conducted. The parts and the method of analysing are the same as Chapter 3 to be able to compare the results. The flows have some changes that were done during the planning and are more precisely described in Chapter 5.

Table 4.1 Area of the new production facility

Facility	Total area (m ²)	Assembly (m ²)	Manufacturing (m ²)	Warehouse (m ²)	Office (m ²)	Other (m ²)
New factory	2340	741	152	307	600	170 outside covered storage

4.1 New and old factory layout comparison

Table 4.2 Old and new production departments comparison

Production department	Old area (m ²)	New area (m ²)	Difference (%)
Intake and quality control	6,16	62,4	912,99
Raw material warehouse and preparation	61,15	61,06	-0,15
Machining and unfinished products	36	77,8	116,11
Warehouse	286,68	260,6	-9,1
Mechanical preassembly stations	0	93	-
Electrical pre assembly stations	25	62	148
Main assembly and transport area	781,02	581,56	-25,54
Total	1196,01	1198,42	0,2

Differences are described in the Table 4.2 and calculated with following formula 4.1. Positive difference means that the area has increased, negative means decrease.

$$\text{Difference} = \frac{\text{New area} - \text{Old area}}{\text{Old area}} \times 100\% \quad (4.1)$$

The change has increased overall production departments area by 0,2% (2,41 m²). Table 1.1 and Table 4.1 show that the assembly area has decreased 106 m² in total. This comes mainly from having all the areas under one roof. There could have been a significant decrease, but the new factory has the possibility for implementing new work areas and processes that are not yet put to work (e.g. welding centre).

The main increase is in intake and quality departments with 912,99%. This is due to Windak OÜ now being responsible for the spare parts and service department also so the warehouse will be increasing and a better system needs to be created. The initial plan takes into account that the warehouse may need more space in the future and there is room to spare for it. Also, new areas decrease the misunderstandings that happened at the old factory due intake and quality being a part of the warehouse. Problems were caused when it was not understood whether the parts are controlled and registered or not. With a designated area for intake it would be clearly visible to everyone what parts are waiting to be checked for quality standards.

Raw material warehouses will be the same size as previously. Since there is going to be a need for increased material a rack system is implemented for the operator to access the raw material himself and transport it to the sawing area. A more detailed description is in Section 5.1.

Machining and unfinished product area will have increased in floor surface by 116,11% with the readiness to have new machines installed in the area. The next machine that is planned is a welding station (red in Figure 4.2). The electrical pre-assembly station 2 and utility area (blue in Figure 4.2) will be compressed in size and will be changing places with electrical pre-assembly station 1 (green in Figure 4.2).

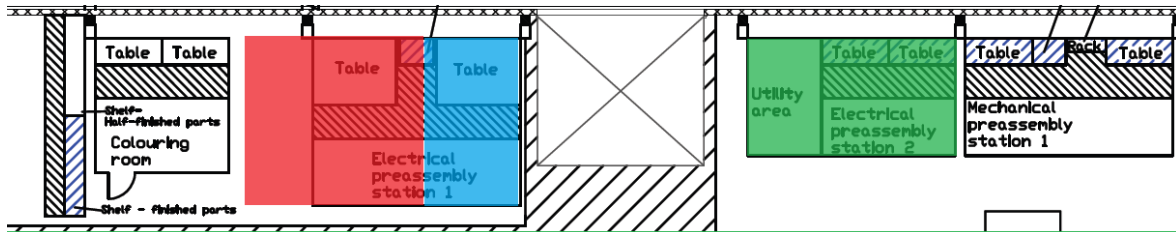

Figure 4.2 Possible location for welding station

Warehouse area will decrease due to having the whole department in the same place. In the old factory, warehouse shelves were in two different houses and in six different areas. The consumables warehouse (blue shelves in Figure 4.3) will be open for everybody to access, without warehouse workers recording the material, this eliminates unnecessary traffic in the warehouse as there have been problems with parts being taken without officially issuing them, the warehouse will be surrounded by walls with only two exits, one going in the quality control station and other will be the issuance exit. Right now there is one workstation for warehouse managers, but there is readiness for a second employee.

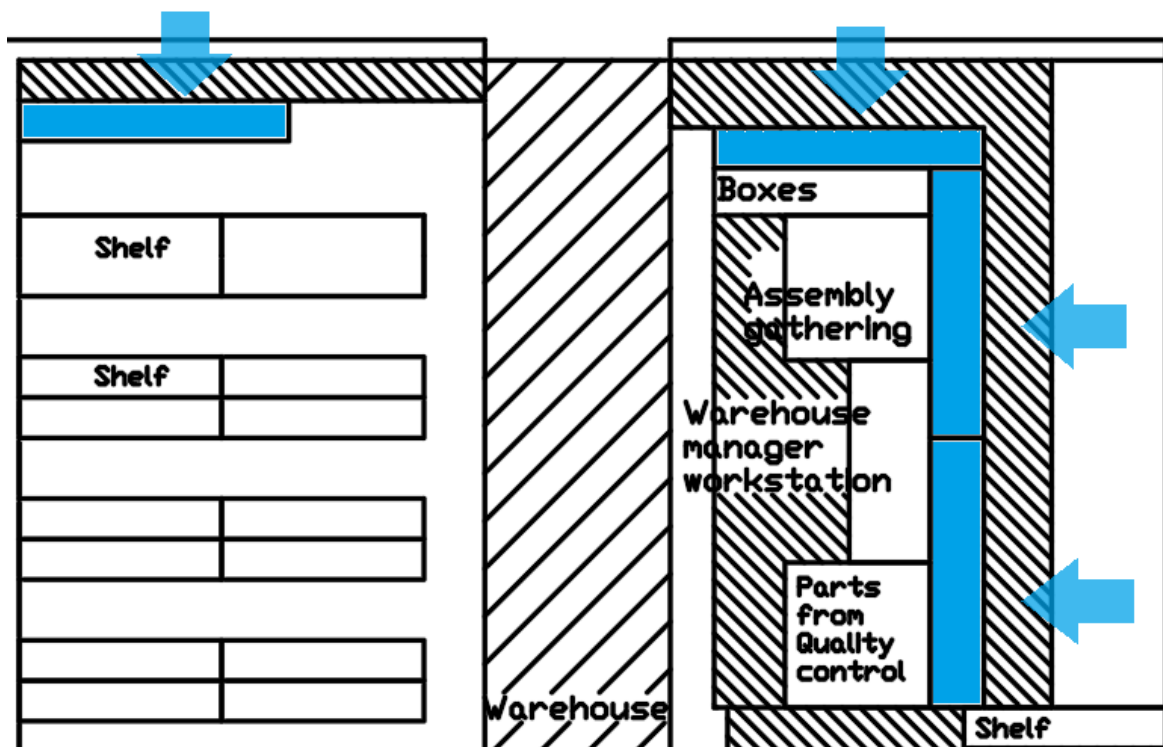

Figure 4.3 Shelves accessed outside of the warehouse

Mechanical preassembly area is a new department that didn't exist in the old factory. These are areas where assembly workers create mechanical assemblies that are transported with overhead cranes to the main assembly site to be fixed to the main machines. At the old factory, each mechanical assembly worker had a table with wheels and located himself where he wanted. This caused problems with discipline and increased distance that workers had to walk to get the needed supplies. Movable tables will be used in the main assembly areas, but preassembly stations will have personal tables with tools (blue in Figure 4.4), fasteners racks (red in Figure 4.4) and a computer per station (green in Figure 4.4). This equipment will satisfy the main need for assembling parts.

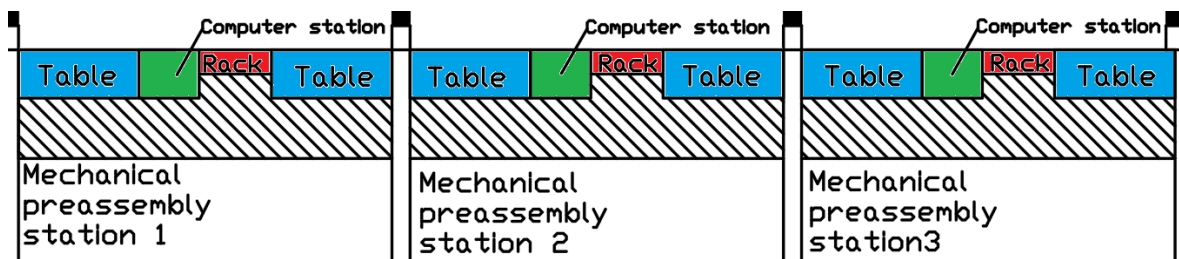

Figure 4.4 Mechanical pre-assembly stations

Electrical pre assembly area has increased 148% by having one more station and expanding the size of the station due to having big tables for assembling. Old factory had an electrical pre assembly area, but the space was often required for main assembly. Main activities are assembling electrical cabinets for the machines. Each machine has its own cabinets which makes 2-4 cabinets per main line. The cabinet assembly station needs to be clean and dust free for quality work. Usually one cabinet takes 1-3 weeks to assemble. The second station is meant for other electrical works like cable preparation and smaller electrical assemblies. There is readiness to give one station to the machining department and to move in a new place since the station can be easily moved.

Main assembly area has decreased by 25,54% by having all areas under one roof. The decrease mainly came from creating the new mechanical pre assembly areas. These areas will decrease the area required for the main assembly by only having the room for the line and not for the workers. The area will have communal stations for assembly workers for fixing the assemblies to the main line. All the assembly that can be performed at the preassembly station is done there. Transport area is for packing and transporting the finished lines. Transport area didn't exist in the old factory and packing had to be completed outside of the building, which made it dependent on the weather. Transport area is needed only when packing and transporting the line. At

other times it can be used as an intake area for big parts (like frames and safety covers). It has to be noted that a pathway from the office to the intake area can be also used as a transport area when the right-handed line is being transported and there are other lines in front of it. Therefore the pathway and the edge of the assembly area need to be placed accordingly.

4.1.1 Designed subcontracted part 20-078729-1 flow

The approximate time in Table 4.3, Table 4.4 and Table 4.5 is calculated based on previous experiences and nature of the trajectory. The flows are depicted on the drawing with file name New3 in the graphical materials. The duration can be shorter or longer due to understanding that the better system at the new factory reduces waiting, searching and transport time.

Table 4.3 Part 20-078729-1 flow in the new factory

No.	Description	Time	Distance	Value Code
	Part no. 20-078729-1. Designed by Windak OÜ, subcontracted parts	(min)	(m)	(V/N/R)
1	Package is delivered and signed for, drawing is placed to the incoming folder	1,1	16	V
2	Package waits in the inbox to be checked by quality	40	40	N
3	Quality takes and unwraps the package	0,8	10	N
4	Quality checking	6,5	0	N
5	Placing the part to the "Checked" shelf, drawing is placed to the "checked" folder	0,4	9	N
6	Waiting for warehouse worker to pick the tray	40	0	N
7	Warehouse worker inserts the part to the system	0,5	2	N
8	Warehouse worker places the item to the correct shelf	0,75	30	N
9	Waiting	7296	0	N
	Total	7386,05	107	

Main time and distance saved is on waiting and transporting items, since the new location creates better communication between quality check and warehouse. The total waiting time before arriving to warehouse has changed from 105 minutes to 80 minutes, reducing the activity by 24%. The total time was changed from 7414,75 minutes to 7386,05 minutes (the main time comes from waiting on the shelf at the warehouse). The distance was reduced from 134 meters to 107 meters, reducing the transport motion waste 21%.

4.1.2 Designed self-produced part 20-022000 flow

Table 4.4 Part 20-022000 flow in the new factory

No.	Description	Time	Distance	Value Code
		(min)	(m)	(V/N/R)
	Part no. 20-022000. Designed by Windak, self-produced parts			
1	Production planner sends an order drawing to the operator, operator learns the drawing	3	0	N
2	Operator goes to warehouse	0,5	23	N
3	Operator prepares the blanks	28	12	R
4	Operator brings the blanks to the workstation	3	11	N
5	Operator manufactures the order	7	4	V
6	Operator places the order to the finished shelf	0,3	14	N
7	Package waits on the shelf to be taken by warehouse worker	30	0	N
8	Warehouse worker transports the item to the intake area	2	88	N
9	Quality checking	6,5	0	N
10	Quality sends the part to subcontractor for surface treatment	10	16	R
11	Package is delivered and signed for, drawing is placed to the incoming folder	1,1	16	V
12	Package waits in the intake area to be checked	40	40	N
13	Quality takes and unwraps the package	0,8	10	N
14	Quality checking	6,5	0	N
15	Placing the part to the "Checked" shelf, drawing is placed to the "checked" folder	0,4	9	N
16	Waiting for warehouse worker to pick the tray	40	0	N
17	Warehouse worker inserts the part to the system	0,5	2	N
18	Warehouse worker places the item to the correct shelf	0,75	30	N
19	Waiting	5904	0	N
	Total	6084,35	275	

The overall flow time has reduced from 6149,55 minutes to 6084,35 minutes and distance needed to travel has decreased 43%. Main changes are due to using computer to receive the order and changing the location of the raw material warehouse closer to the machining station. The process of receiving the order and preparing the blanks has decreased 36% from 54 minutes to 34,5 minutes. Similar to the part 20-078729-1 flow at the new factory, the waiting times has decreased.

4.1.3 Purchased standard part 81-000345 flow

Table 4.5 Part 81-000345 flow in the new factory

No.	Description	Time	Distance	Value Code
	Standard parts, off the shelf parts	(min)	(m)	(V/N/R)
1	Package is delivered and signed for	1,1	16	V
2	Package waits in the inbox to be handled by warehouse	30	0	N
3	Warehouse empties the tray and takes it to the warehouse	1	24	N
4	Warehouse checking of the order and a part	2	0	N
5	Warehouse worker inserts the part to the system	0,5	2	N
6	Warehouse worker places the item to the correct shelf	0,75	30	N
7	Waiting	8880	0	N
	Total	8915,35	72	

Similar to other two parts the biggest change is reduced waste in waiting. Also the change in the layout from intake to warehouse has shortened and reduced transport time and distance. The overall time has decreased from 8935,35 minutes to 8915,35 minutes. The distance has shortened 44% from 128 meters to 72 meters.

4.1.4 Assembly 02-4005-B2 flow

Assembly 02-4005-B2 flow in the new factory is described in the Table 4.6

Table 4.6 Assembly 02-4005-B2 flow in the new factory

No.	Description	Time	Distance	Value Code
	Assembly 02-4005-B2 Length counter	(min)	(m)	(V/N/R)
1	Warehouse worker gets an work order to gather an assembly	2	0	N
2	Warehouse worker gathers assembly into a box	8	75	N
3	Warehouse worker transports the box to the pre assembly area	3,5	84	N
4	Mechanic walks to the computer to start the job in the ERP system	0,3	6	N
5	Mechanic assembles the assembly	52	6	V
6	Supervisor comes and checks the quality of an assembly	4	12	N
7	Mechanic walks to the computer to finish the job in the ERP system and gets new work order to assemble the assembly to the main frame	0,46	6	N
8	Assembly is transported to a main line	8	20	N
9	Assembly is assembled to a main frame	9	2	R
10	Supervisor comes and checks the quality of an assembly	3	45	N

No.	Description	Time	Distance	Value Code
	Assembly 02-4005-B2 Length counter	(min)	(m)	(V/N/R)
11	Mechanic walks to the computer to finish the job in the ERP system	0,38	20	N
12	Mechanics clean their area	15	20	N
	Total	105,64	296	

The biggest change that new layout has brought up is the decrease time in cleaning the work areas. Since each worker has their own station, the cleaning procedure is smoother and more convenient. The overall time for the part to be gathered at the warehouse to being assembled on the machine has decreased 25% from 140,4 minutes to 105,64 minutes. The overall distance has decreased 48% from 568 meters to 296 meters. Taken into account of all the results from all the parts analysed it can be said that the new layout has decreased mainly waste in motion and waiting.

4.2 KPI analysis comparing old and new factory

The relocation is a onetime project, but the layout of the factory can be changed according to the future requirements of the company. KPIs chosen for the layout are applicable with principles brought out in Section 2.4. 8 KPIs were selected and analysed to make an overall conclusion. The **Error! Reference source not found.** oncludes the data from both factories and calculates the differences. Differences are calculated according to formula 4.1. The time period that a part is waiting on the warehouse shelf is not taken into account, since it is due to procurement processes that are not analysed in this thesis. Figure 4.5 and Figure 4.6 describe the part and assembly flows that are taken for KPIs.

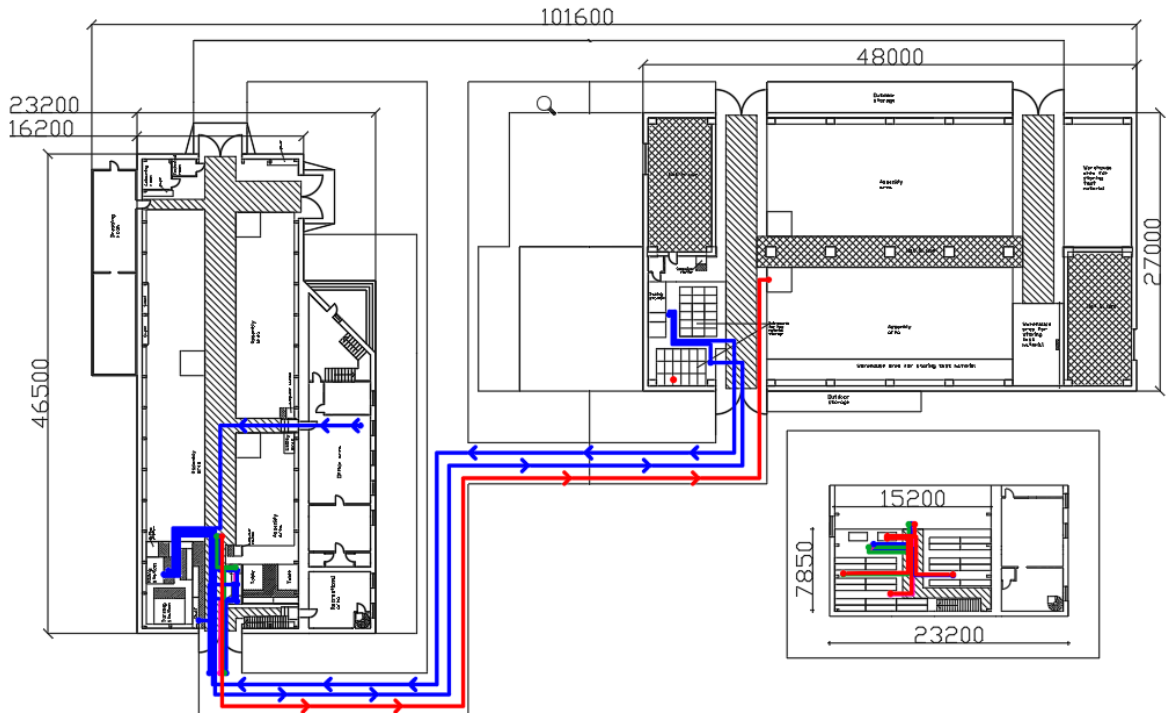

Figure 4.5 Old factory part flows

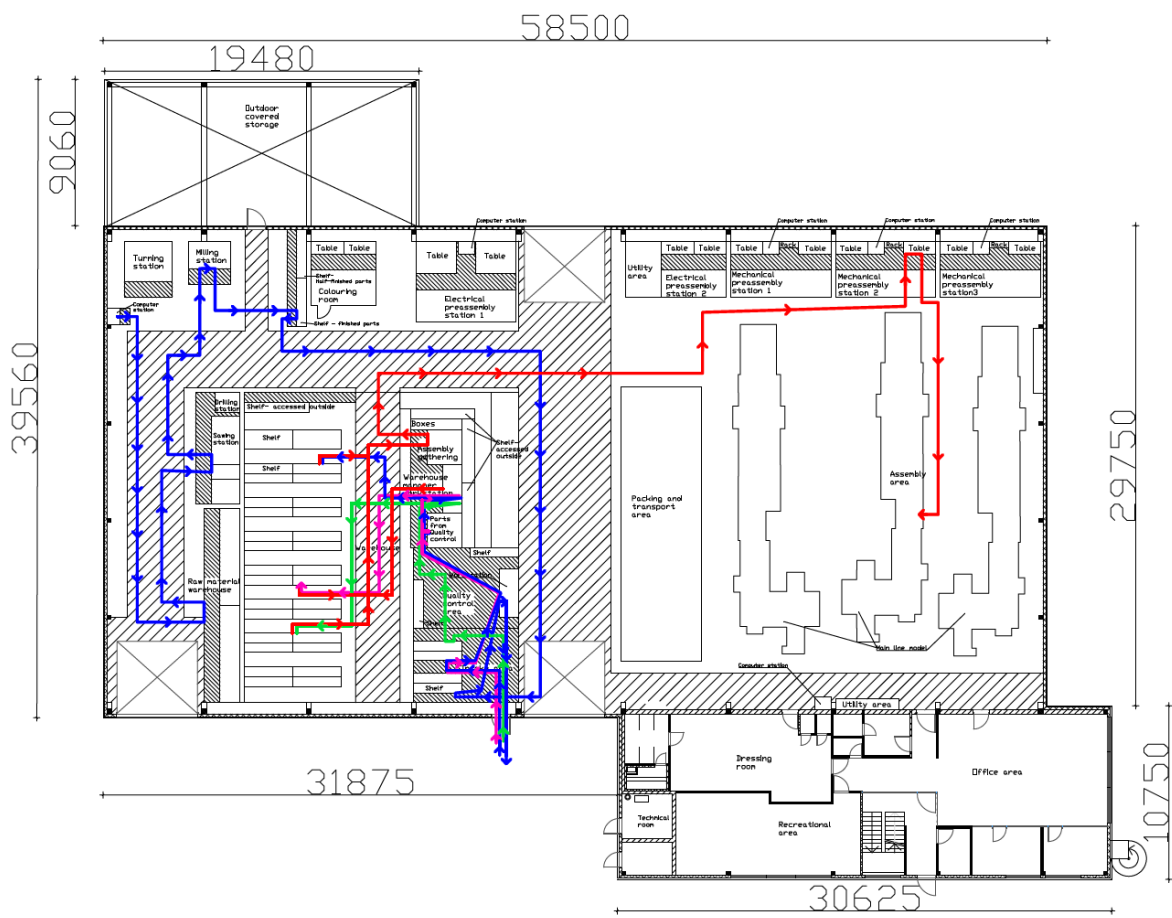

Figure 4.6 New factory part flows

Table 4.7 Old and new factory difference in KPIs

KPIs	Old factory	New factory	Difference
Part no. 20-078729-1 distance from arriving to warehouse	134 m	107 m	-20,15%
Part no. 20-022000 distance from ordering to warehouse	480 m	275 m	-42,71%
Part no. 81-000345 distance from arriving to warehouse	128 m	72 m	-43,75%
Part no. 20-078729-1 time from arriving to warehouse	118,75 min	90,05 min	-24,17%
Part no. 20-022000 time from arriving to warehouse	281,55 min	182,35 min	-35,23%
Part no. 81-000345 time from arriving to warehouse	55,35 min	35,41 min	-36,03%
Assembly flow distance from gathering at warehouse to main machine	568 m	296 m	-47,89%
Assembly flow time from gathering at warehouse to main machine	140,4 min	105,64 min	-24,75%
Non-value adding activities (part 20-078729-1)	20	18	-10,00%

In overall all the KPIs indicate the changes have reduced the waste. The assembly flow distance from gathering at the warehouse to the main machine was reduced the most by 47,89%. That is a 272 meters shorter flow and saves time of 34,75 minutes. The least successful change has been decreasing the non-value adding activities in the process, by only removing 10% on these. This is one part that needs to be looked into more thoroughly, since changing overall processes can have a positive impact on the whole outcome.

Waiting time was not chosen for a KPI since this thesis focuses on processes in the factory area from quality check to assembly. Waiting time is mainly caused by purchasing and production planning processes that are not thoroughly addressed and analysed in this thesis. The author gives recommendations for improving purchasing and production planning in chapter 6. Also the area for each department wasn't chosen for a KPI because the new factory has the room for more growth. Therefore right now the area is bigger than previous and this means that the departments have more room. If the company will evolve, layout will change according to their needs.

The gain from the change is calculated in the Table 4.8 with formula 4.2. It is done by finding the reduced work time for relevant workers. The difference is multiplied with workload that the worker has for the applicable tasks. For example, warehouse worker does the part gathering 75% of their time, additional 25% is for other tasks. The difference with workload is multiplied with the average wage cost for the company. The savings for a month and for a year are calculated. The total savings per year is calculated for payback period calculations in Chapter 7. The average wage is taken from Appendix 5.

Table 4.8 Improvements gain calculation

Description	Unit	Quality check	Warehouse worker	Assembly worker	Operator	Production Planner	Super-visor
Old flow time	min	39,4	38,35	113	58	4	7,3
New flow time	min	35,2	22,25	85,14	41,8	0	7
Difference	%	10,7	41,98	24,65	27,93	100	4,11
Workload	%	95	75	95	95	1	2
Difference with workload	%	10,1	31,5	23,4	26,5	1	0,08
Workhours	h/mo	160	160	160	160	160	160
Average wage	€/h	9,3	9,3	8,04	10,94	14,22	14,22
Workers quantity	pcs	1	1	6	2	1	1
Savings per month	€/mo	150,7	468,57	1807,65	928,76	22,75	1,82
Savings per year	€/yr	1808,8	5622,85	21691,79	11145,15	273,02	21,84
Total	€/yr	40563,5					

$$Savings\ per\ month = Difference\ with\ workload \times Workhours \times Average\ wage \times Workers\ quantity \quad (4.2)$$

5 IMPROVEMENTS FOR THE NEW FACTOR

To describe the changes that are recommended for implementation in the new factory the production area is divided into three areas. The first area is the manufacturing unit with raw material warehouse, preparation and machining. Second part is the intake, quality control and warehouse for manufactured and purchased parts. Third is the assembly area for pre assemblies and main assemblies with testing and disassembling areas. Improvements are depicted in the appendix on a Figure 5.1 and in graphical materials on a drawing with file name New4.

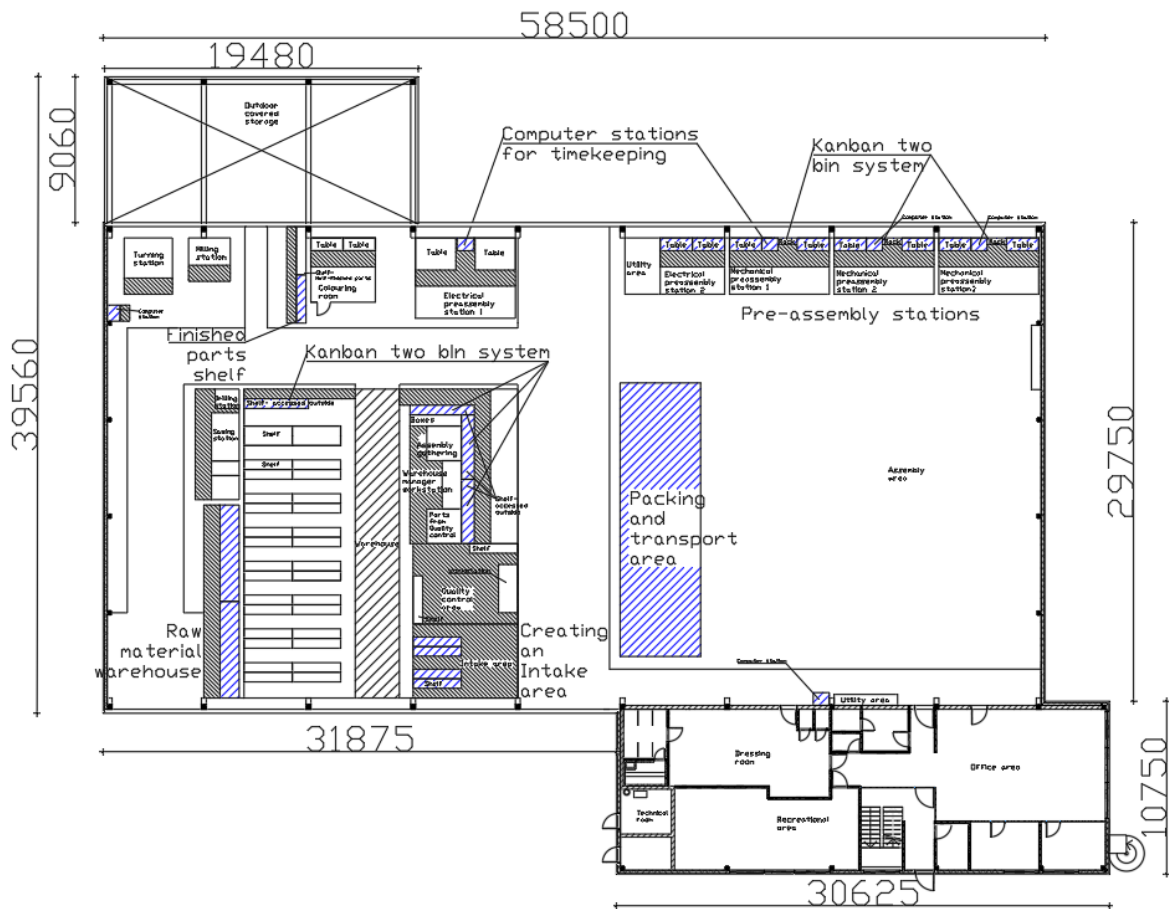

Figure 5.1 Improvements in the new factory

5.1 Improvements in the manufacturing area

Manufacturing unit needs a new raw material warehouse system. At the moment the raw material is stored on the EUR-pallets in the rented building. The company has a goal to increase manufacturing of the parts so the raw material stock is expected to increase. The system needs to meet the following requirements:

- Maximum length for the raw stored material is 3 meters;
- Maximum weight to store on one rack is 1 tonne;
- Forklift accessibility to the warehouse;
- Overhead crane accessibility to the warehouse;
- One side storage option.

The author proposes a cantilever rack that has a pull out system so that overhead cranes with magnet grippers can be used. This solution also enables for one person to work on receiving the material. The solution can be seen in Figure 5.2.

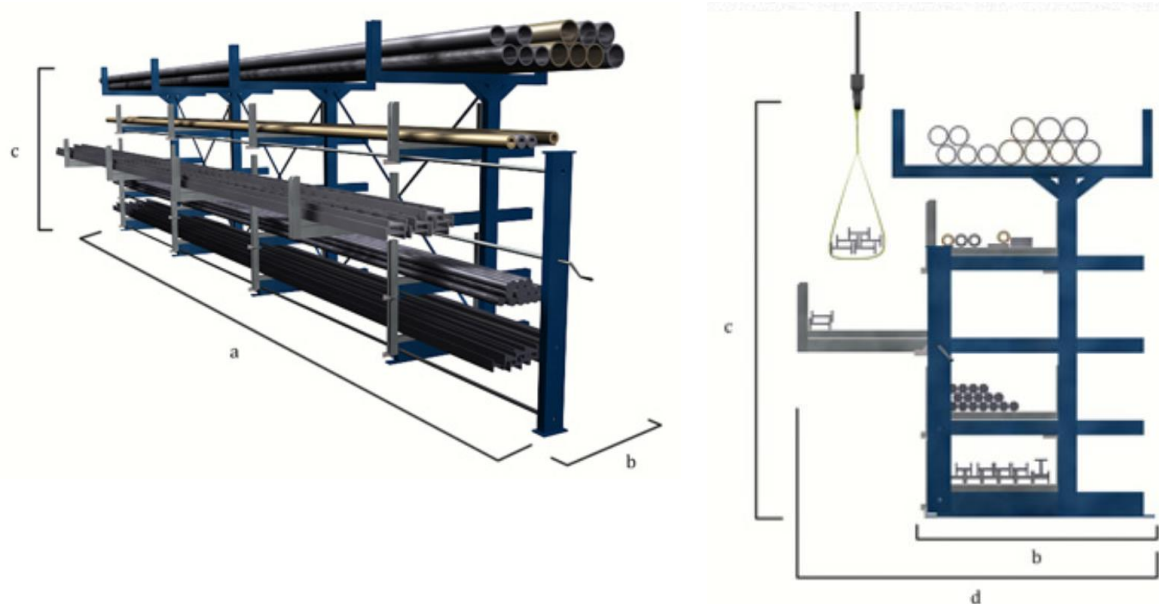

Figure 5.2 Cantilever rack with pull out system [23]

The saw has a special conveyor made for raw material to hold the 3 meter bar while sawing it. The milling and turning machines will be close to the sawing area and there is also allocated room for welding, extra CNC, laser and bending machines for future developments. Finished products will be stored at the designated shelf.

Since this is a suggestion given to Windak and not mandatory change (since the material has room on the floor for now) an opportunity cost is calculated. Opportunity cost is cost that company misses out due to having chosen one solution over another.

[24] To get the opportunity cost the warehouse floor area is calculated and compared with a renting cost of 6 €/m².

The EUR-pallet solution is calculated by adding the floor cost and EUR-pallet cost per year. Area size is the same as in the old factory of 35 m². The floor cost per month is calculated by multiplying area and the rent. Since one EUR-pallet area is 0,96 m², 36 EUR-pallets are needed. The cost for one pallet is 5 € every 12 months for renewing them.

$$\text{Floor cost} = \text{Area} \times \text{Rent} = 35 \text{ m}^2 \times 6 \frac{\text{€}}{\text{m}^2} = 210 \text{ € per month} \quad (5.1)$$

$$\text{EUR - pallet cost} = \frac{\text{Quantity} \times \text{Price}}{12} = \frac{36 \times 5}{12} = 15 \text{ € per month} \quad (5.2)$$

$$\text{Total cost for EUR - pallets} = \text{Floor cost} + \text{EUR - pallet cost} = 210 \text{ €} + 15 \text{ €} = 225 \text{ € per month} \quad (5.3)$$

The cantilever rack solution is calculated by adding floor cost and cantilever rack cost. Racks take 6,5 times less room for storing the same amount of material, making the area needed 5,8 m². The price of one cantilever with width of 800 mm and length of 1500 mm is 1500 € and for the same amount to stock 5 cantilevers are needed. The total price for the rack is 7500 €. The lifespan for a rack is estimated to be 20 years.

$$\text{Floor cost} = \text{Area} \times \text{Rent} = 5,8 \text{ m}^2 \times 6 \frac{\text{€}}{\text{m}^2} = 34,8 \text{ € per month} \quad (5.4)$$

$$\text{Cantilever cost} = \frac{\text{Cantilever price}}{20 \times 12} = \frac{7500}{20 \times 12} = 31,25 \text{ € per month} \quad (5.5)$$

$$\text{Total cost for cantilevers} = \text{Floor cost} + \text{Cantilever cost} = 34,8 \text{ €} + 31,25 \text{ €} = 66,05 \text{ € per month} \quad (5.6)$$

$$\text{Opportunity cost} = \text{Total cost for EUR - pallets} - \text{Total cost for cantilevers} = 225 \text{ €} - 66,05 \text{ €} = 158,95 \text{ € per month} \quad (5.7)$$

The one time investment for the cantilevers will be much higher than EUR-pallet costs. The author recommends the new rack solution since in the long run the costs are lower and floor space will be freed for value adding activities.

New shelves are needed for finished parts. Operators used to be the ones who transport finished parts to the intake area. Since the walking distance to the intake area and back is 90 meters, a shelf is placed in the manufacturing area for finished

products. The warehouse worker routinely empties the shelves. There is total of two shelves, one for half-finished and another for finished products. The cost for the shelves is calculated with a formula 5.8.



$$\text{Cost of the shelves} = \text{Quantity} \times \text{Shelf price} = 2 \times 200 \text{ €} = 400 \text{ €} \quad (5.7)$$

5.2 Improvements in the warehouse area

The warehouse needs smooth movement of parts that come from machining units and subcontractors, pass through quality control and end up at the warehouse shelves from where they are gathered and sent to the assembly area. Windak OÜ is responsible for the service and spare parts department also. A key improvement to the layout was bringing quality control together with the warehouse as the old factory had them on separate floors which made the transport and communication slower.

Extra marking for the parts before moving needs to be implemented to determine whether they are needed, scrapped or sold. The labels should be different colours so that no further distinguishing is required. For example, a green sticker means that the part will be moved to the new factory, yellow indicates that it should be sold and red is directly scrapped. Also notes can be written on labels as it can be seen on Table 5.1.

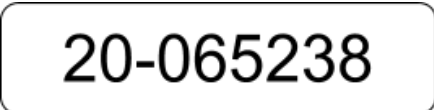
Table 5.1 Labelling system for warehouse inventory

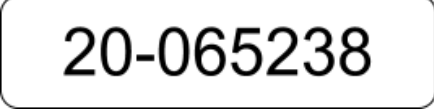
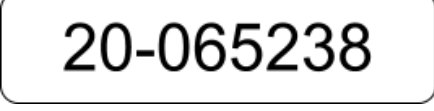
Part markings	Description
	Part waiting to be marked according to its destination.
	Part that can be sold.
	Part that will be scrapped.
	Part that will be kept and relocated to the new factory.

Kanban two bin system implementation is the main organisational changes taking place in the warehouse system and one of the changes that will be implemented by Windak OÜ. [15] Two bin systems can be implemented to the racks that face out of the warehouse and where the workers can take inventory without the warehouse issuing them. These parts are different fasteners, pneumatic hoses and electrical cables. The system will work as according to the pick-place-pull method.

The worker will pick an item that is needed, then if the box is empty, places it to the empty bin location and then pulls out a new bin from behind the old one that is filled with the same items. The warehouse worker will see the empty bin and fill it with the same items and place the bin behind the current one. The system will also be implemented to the assembly station racks. Since there is no room for two bins, a divider is used to mark the refilling point and a special card that has information about the product and the quantity is put into the "empty card bin" where the warehouse worker takes it and refills the bin accordingly. A warehouse worker will check the empty bin/card areas according to the need. The bin label and Kanban card both have part number, the quantity that needs to be in the box and the location of the box. The labels and cards are depicted in Figure 5.3. The cards are coloured red to differentiate them from other bins used in the warehouse.

Implementing the system at the same time as moving is suitable, since the positions for items need to be changed. Advantages for this system are that the potential shortages will be seen beforehand; it enables to have more space in the pre-assembly area, and increases the distribution efficiency.

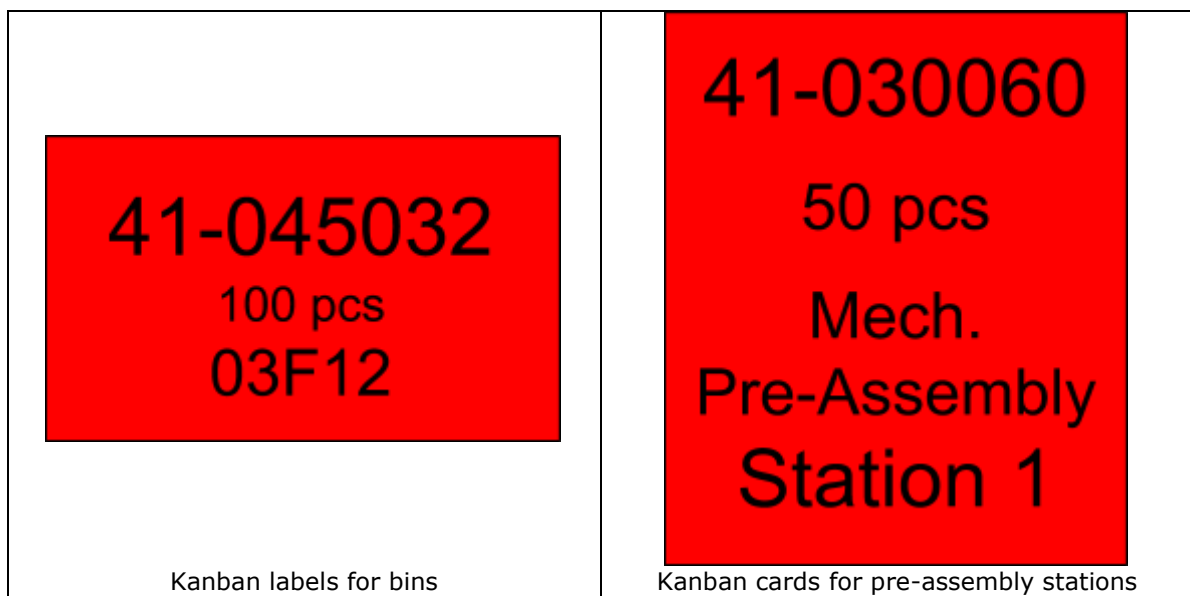

Figure 5.3 Kanban label and card sketches

Cost for implementing Kanban two bin system can be calculated by the cost of inventory that is needed and the time that it takes for workers to learn the new system. The cost is calculated for calculating the total cost of the relocation.

Cost of inventory comes from needing new bins for each applicable position, dividers for pre-assembly bins, and resources needed to create the bin labels and cards. 232 bins will be in the system and 112 cards are needed. 12 people will be involved with the system. The average wage per hour is shown in Appendix 5.

$$\text{Bins cost} = \text{Quantity} \times \text{Price} = 20 \times 2,5 \text{ €} + 20 \times 5,5 \text{ €} + 20 \times 9 \text{ €} = 340 \text{ €} \quad (5.8)$$

$$\text{Dividers cost} = \text{Quantity} \times \text{Price} = 14 \text{ bins} \times 8 \text{ pre-assembly areas} \times 2 \text{ €} = 224 \text{ €} \quad (5.9)$$

$$\text{Labels and cards cost} = \text{Quantity} \times \text{Cost per piece} = 344 \text{ €} \times 0,3 \text{ €} = 103,2 \text{ €} \quad (5.10)$$

$$\text{Training cost} = \text{Workers} \times \text{Time} \times \text{Average wage} = 12 \times 4 \text{ h} \times 9 \frac{\text{€}}{\text{h}} = 432 \text{ €} \quad (5.11)$$

$$\begin{aligned} \text{Total cost for Kanban} &= \text{Bins cost} + \text{Dividers cost} + \text{Labels and cards cost} + \text{Training cost} \\ &= 340 \text{ €} + 224 \text{ €} + 103,2 \text{ €} + 432 \text{ €} = 1099,2 \text{ €} \end{aligned} \quad (5.12)$$

5.3 Improvements in the assembly area

The assembly area is divided into two main areas, pre-assembly stations and the main machine assembly area. The packing area, where main machines are packed for transport, is also part of a main assembly area. The new factory will provide the ability to pack inside the house since the containers can be placed inside the house. At the old factory, there was no room for that and the containers stayed outside while packing. Making the packing process uncomfortable and affected by the weather.

The biggest improvement for the assembly area is the pre assembly stations for mechanical assembly. Old factory had only an electrical pre-assembly station. Each station has workplaces for two workers. Workstations are special orders so that they would have a hardcover desk, individual lighting system, wall and drawers for tools and safety gear, boxes with most used fasteners and an area for drawings, work orders and quality documents. The stations drawings are depicted in Figure 4.4 and

the inventory in them look similar with Figure 5.4. Also the area will have a shelf for finished assemblies and unfinished. This will give a quick overview where the downtime comes from, is there a problem with some part in an assembly or with the main machine. Also one computer is per workstation for looking at drawings in 3D and to insert the work hours.

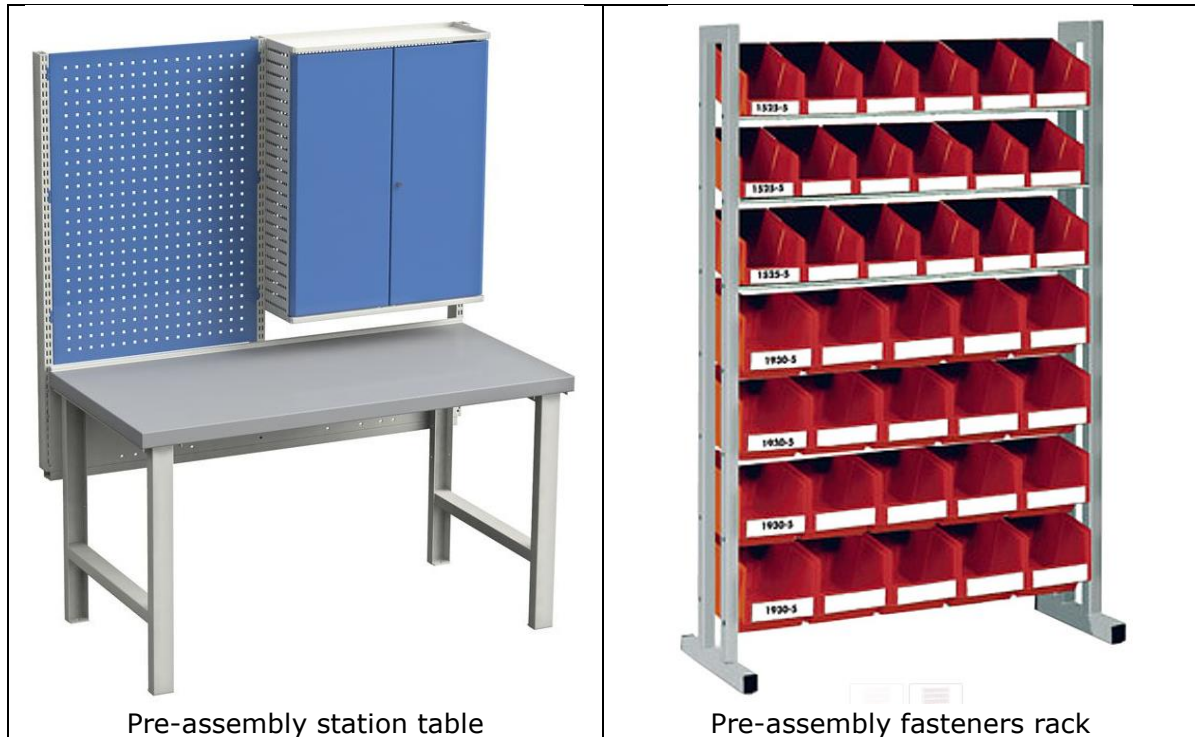

Figure 5.4 Pre-assembly station furniture [25]

The price for one table is 850€, since 6 tables are needed, the total cost for the tables is 5100€. Three fasteners racks are added with the cost of 300 € each. Total cost is 6000 €. This cost will be used for the payback calculations. The main purpose of this system is to save time on assembling the machines, so the time from the assembly worker receiving the gathered assembly by warehouse until the assembly is fixed and the workplace is cleaned is taken into account.

Timekeeping system also needs improvement since workers don't want to use it right now due to being inconvenient. Timekeeping is done using ERP, computers and work orders. Windak uses the Monitor ERP system for accounting, BOMs, procurement, warehouse and assembly. [26] Assembly workers' work orders come from ERP. All the work orders have special 6-digit code that has to be inserted to the ERP system when the job is started, paused, restarted and finished.

Old factory had a problem with not having enough computers at the production hall for the workers to update the work status properly. Long distances that were needed to

walk to get to the computer made workers wait until a convenient time appeared to go update the status. This wasted time and overall information wasn't precise. The old factory main building had two computers for work registration and the rented house had one computer.

In the new factory four computers will be used in pre-assembly areas and one will be used in the main assembly area. The workers also use them to view 3D drawings of the assemblies. These stations are named "Computer stations" in the layout drawings. For the new plan 2 new licences and computers are purchased. The stations look similar to Figure 5.5 and can be seen from the Figure 4.4 as a part of the mechanical pre-assembly stations. The cost will be used when payback period is calculated.

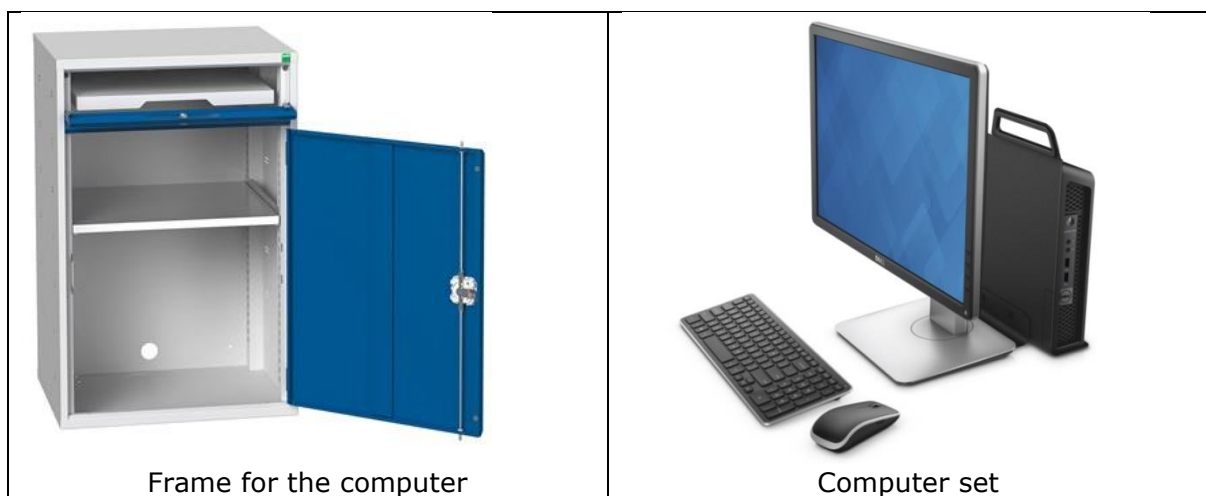

Figure 5.5 Pre-assembly computer station [27] [28]

Cost for one workstation includes the frame, computer, and the Monitor ERP licences. Frame for the computer price is 100 €, computer is 250 € and the Monitor ERP licence for 1 computer per month is 30€, total for a year is 360 €.

$$Total\ cost\ for\ the\ extra\ computers = Quantity \times (Frame \times Computer \times Licence) = 2 \times (100 + 250 + 360) = 1420 \text{ €} \quad (5.13)$$

Total cost is added to the final calculations to find out how much the relocating cost.

6 RELOCATION ACTION PLAN

The author of this thesis will be a consultant for this project and suggests a 9 step plan with details based on the facilities planning process chart (Figure 2.2). Steps 1-4 are done before receiving the keys for the new factory. Steps 5-11 are executed on site.

1. Create a team that will be responsible for the relocating. Each person is responsible in one segment of the process. Budget, layout, schedule and targets are recorded.
2. Sorting is executed. This step also includes choosing what equipment will be relocated and what will be sold or scrapped. All the equipment is labelled according to its destination.
3. Layout of the new factory is created.
4. Transport plan is created.
5. Marking of the new factory.
6. Transport is arranged.
7. Equipment is installed and calibrated in the new factory.
8. Inventory check is executed to assess if everything is according to the plans.
9. Test run is executed to check if everything works properly.
10. New factory introductions to Windak workers are performed with new work methods and ethics.
11. Work starts at the new factory.

Based on these steps the first action is to create a team that will be responsible for relocating. The plant manager will be the overall project leader who forms a team and preliminary budget that is monitored by the financial manager. The property manager will be in charge of sorting the inventory before the move, marking the new factory layout and transport. The procurement manager sells the designated things and conducts the inventory. The production manager will be responsible for having the production ready for relocating. Final step is the launch by the plant manager.

To estimate the workload for each manager due to the relocation project and to improve communication within the company a RACI matrix was conducted (Table 6.1). It's a responsibility assignment matrix, where RACI means following statuses: responsible, accountable, consulted and informed, that is assigned to a stakeholder depending on the activity. Responsible is a stakeholder who has been assigned responsibility for delivering a task, accountable is ultimately answerable for the completion of the task, consulted stakeholder is a key person who must be consulted

regarding the activity and informed stakeholder needs to be kept up on date with progress. [29]

Table 6.1 RACI matrix for relocation project

<h2 style="text-align: center;">RACI Matrix</h2> <p style="text-align: center;"> R - Responsible A - Accountable C - Consulted I - Informed </p>		Stakeholders							
		Plant Manager	Production Manager	Procurement Manager	Property Manager	Financial Manager	Engineering Manager	PLC Programming Manager	Additional workforce
Activities/Deliverables	Form a project team	R/A	C	C	C	C	C	C	
	Prepare estimated cost	R/A	I	I	I	C			
	Monitoring the budget	A	I	I	I	R			
	Sorting execution	I	R	R/A	R				
	Selling/scrapping old equipment	C	C	R/A	C	C	C	C	
	Creating a production plan	I	R/A	C	C		C	C	
	Creating a transport plan	I	R	R/A	R	I	I	I	I
	Marking the new factory layout	I	C	C	R/A	C	C	C	I
	Transport of inventory	I	R	C	R/A				R
	Inventory execution	I	R	R/A	R				
	Launch	R/A	I	I	I	I	I	I	

A Gantt chart is created for a better overview of the moving status. Gantt chart is a project visualisation tool that has two primary variables with their dependencies, time and tasks. [30] Wrike Gantt chart is used in this thesis. The overall plan is to use summer time for the moving because the factory will have mandatory vacation for most of the workers and that time is used for transport. The mandatory vacation will be held from 13th of July until 2nd of August 2020. Also the decrease in new orders due to the economic recession of 2020 spring lets the moving be faster since the production has less parts/machines in it.

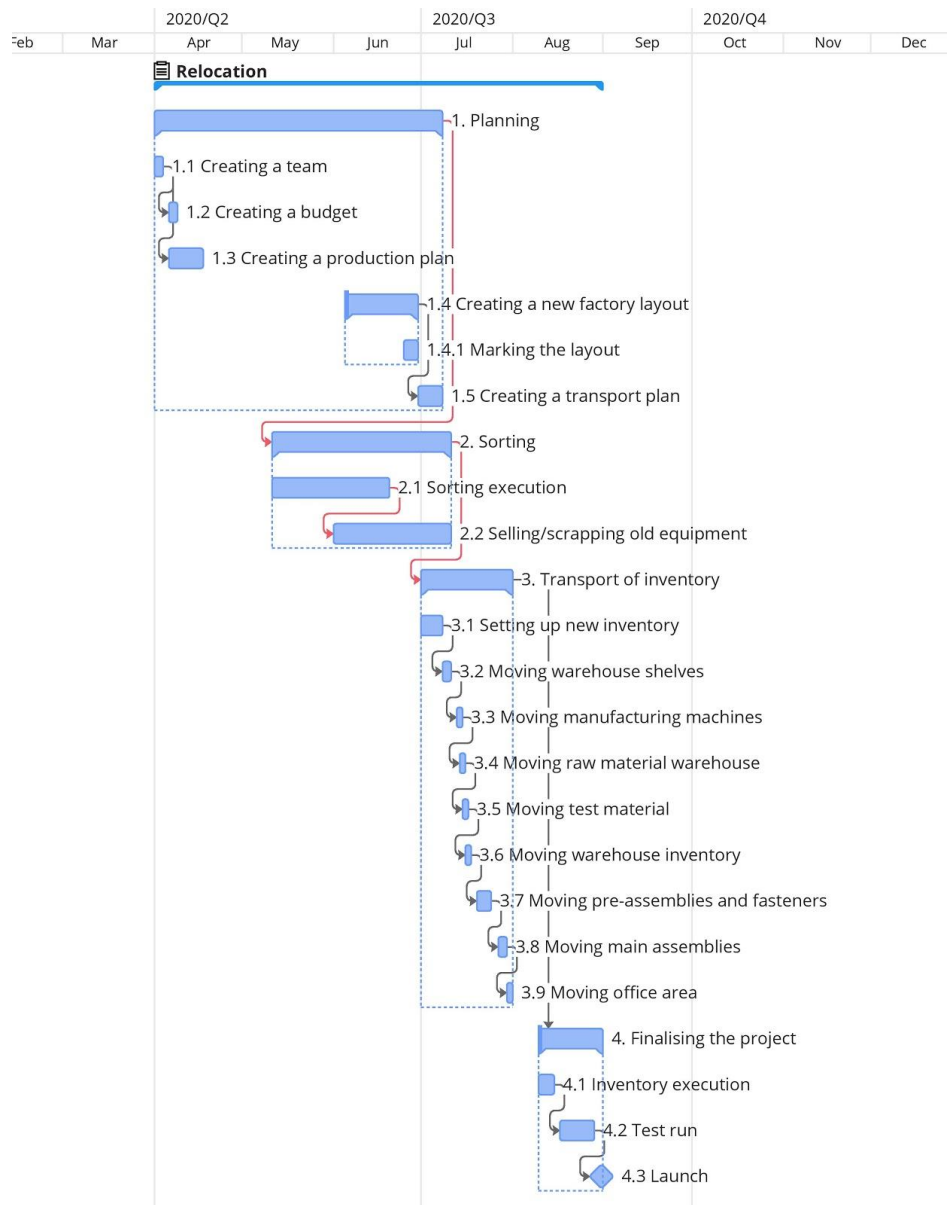

Figure 6.1 Gantt chart for relocation project

The procurement manager will dictate how and when sorting is executed. Sorting should be completed before the actual relocating process, since there must be enough time between the equipment to be sold or scrapped and the moving. The property is sorted and labelled based on the destination: sold, scrapped or kept. Sample of the labels can be seen on Table 5.1. He also sells the unwanted equipment.

At the same time the production manager starts to plan the production to ensure that the machines will be assembled as much as possible at the old factory so that a minimum amount of separate parts need to be relocated. It is easier and less time consuming to transport 20 parts that are assembled into one, than it is to transport them separately.

After the amount of inventory that needs to be relocated is known, a precise transport plan is proposed to the property manager. The milling and turning machines are the first equipment to be sent to the new factory with 40' trucks, since their location is the furthest from the door. After that the raw material storage is transported. The test materials can be transported after them. The warehouse stocks are proposed to be moved next in containers, since the presence of the container weeks before moving can make the transport from warehouse to the loading place more flexible. The same shelves are used so the shelves need to be emptied and set up at the new factory before the parts arrive. Next are assemblies and fasteners. The main lines are to be relocated as a final step for the production area, since they are located the closest to the main door and would be in a way before. The final step is the office area.

Before the transport starts, a property manager is responsible for marking the factory with the locations of different areas. The goal is that all the locations will be well marked so no misunderstandings occur while transporting the inventory. It must be noted that Windak OÜ will have keys handed over in the end of June so the marking period needs to be within 2 weeks before the moving. The markings will be precise, depicting all the machinery, workstations and utility areas.

After the relocation an inventory is executed to see if everything is according to the plans. All the machinery, and implementations, and workers need to be working properly. If better places have been found for inventory, then the factory layout is updated. Test runs are conducted on an on-going basis to check if everything works according to the plan. After the factory is tested the project team concludes the project with timeline and budget updates for upper management.

7 FINANCIAL CALCULATIONS

Financial calculations are made to understand the total cost for the relocating of the factory. All the previously calculated costs for improvements in this thesis are brought out in Table 7.1. Additional costs are personnel costs, lost turnover for relocating period and transport costs. The total cost for Windak OÜ due to the moving is calculated by adding all the previously mentioned costs together (Formula 7.6).

Table 7.1 Cost for improvements

Improvements	Cost
Raw material storage racks	7500 €
Kanban two bin system	1099,2 €
Pre-assembly stations	6000 €
Extra computers at the workstations	1420 €
Total cost:	16019,2 €

Cost for losing the income due to stopping the production is dependent on the length of time the production doesn't generate income. Based on the Gantt chart (Figure 6.1) the total duration for the project is 5 months. The total cost for work is calculated based on the precise timetable (Appendix 5) depicting the personnel occupied with moving processes. Extra 6% is added to the total cost for work for utility costs.

$$\begin{aligned} \text{Personnel cost} &= \text{Total cost for work} + 6\% \text{ for utility costs} = 36646,47 \text{ €} + \\ &36646,47 \text{ €} \times 0,06 = 38845,26 \text{ €}. \end{aligned} \quad (7.1)$$

The lost turnover for the relocation period is calculated based on 2018 turnover, since this is the newest public turnover available. Work hours used is calculated in Appendix 5.

$$\text{Turnover per month} = \frac{\text{Turnover per year}}{12} = \frac{7180000 \text{ €}}{12} = 598333,3 \text{ €} \quad (7.2)$$

$$\text{Turnover per hour} = \frac{\text{Turnover per month}}{12} = \frac{598333,3 \text{ €}}{160} = 3739,6 \text{ €} \quad (7.3)$$

$$\text{Turnover per person per hour} = \frac{\text{Turnover per hour}}{40} = \frac{3739,6 \text{ €}}{40} = 93,49 \text{ €} \quad (7.4)$$

$$\text{Lost turnover} = \text{Turnover per person per hour} \times \text{Work hours used} = 93,49 \times 3723,2 = 348080,42 \text{ €}. \quad (7.5)$$

Transport cost is calculated by the duration of transport which is 23 workdays. To have everything on time one truck is rented for this period. The cost for the truck is 15000 € for this period.

$$\begin{aligned} \text{Total cost for moving} &= \text{Improvements cost} + \text{Personnel cost} + \text{Lost turnover} + \\ \text{Transport cost} &= 16019,2 \text{ €} + 38845,26 \text{ €} + 348080,42 \text{ €} + 15000 \text{ €} = 417944,88\text{€} \end{aligned} \quad (7.6)$$

The cost that is calculated takes into account the main expenses for the relocation activity, work obstruction and improvements brought out in this thesis. It is calculated like that, since the fixed plan for relocation came from the board of directors and as the author consulted on the relocation plan part of the project. The information regarding other cost aspects like real estate investment, maintenance and utility cost was not available for the author.

7.1 Payback period for improvements

The payback period is the length of time for the investment to reach a break-even point. [31] The payback period is calculated taken into account total cost and gain for improvements. The cost and gain is summed up in Table 7.2 from the Table 7.1 and the Section 4.2. The payback period will be calculated with the formula 7.7.

Table 7.2 Improvements cost and gain

Total Cost	16019,2 €
Total Gain	40563,5 €/yr

$$\text{Payback Period} = \frac{\text{Total Cost}}{\text{Total Gain}} = \frac{16019,2 \text{ €}}{40563,5 \frac{\text{€}}{\text{yr}}} = 0,395 \text{ years} \approx 5 \text{ months} \quad (7.7)$$

The cost for improvements is paid back within 5 months. The calculations show that the improvements are profitable and have a positive effect on the production. Even if Windak OÜ wants to change or improve the production within couple of years, the period before that would be profitable.

CONCLUSION

The purpose of this thesis was to help Windak OÜ with moving project by creating a layout for the new factory with improvements in process flows and a relocation plan. The relocation plan was conducted by studying the work flow methods used for moving. A step-by-step guide was given to the company to have as smooth moving process as possible.

New layout with improvements was put together by analysing the part flow, finding the bottlenecks and identifying different wastes that old factory layout had. The new factory was divided into three main areas: manufacturing, warehouse and assembly.

The result of the thesis can be determined to be successful, since the layout with the developments described in the thesis has been taken as a guideline for the new production facility. The proposed ideas are possible to implement without any major changes in the structure of the company. One part of the thesis that is also going to be used in Windak OÜ is the relocation plan with detailed time table for the process to eliminate confusion by appointing tasks directly to personnel.

The most efficient change by analysing the KPIs is the reducing the assembly flow distance from gathering at warehouse to the main assembly area by 47,89% and the time 24,75%. The biggest effect was of bringing the warehouse to the same floor as the manufacturing and assembly areas. The payback period for flow improvements is 5 months, which makes the change profitable.

Pre-assembly stations were implemented to assembly area. These stations were created for electrical and mechanical assembly workers who used to have movable tables that were frequently positioned in private corners of the assembly area, causing time delays due to not having enough control over the workers. By creating stationary areas for assembly workers a better overview of the process is reducing waste.

Warehouse area waste reduction was done by implementing Kanban two bin system to the shelves for consumables at the new pre-assembly stations and in the warehouse. These warehouse shelves are accessed outside without warehouse keeping track on the parts concurrently. The system notifies warehouse worker only when the bins need to be filled, reducing the unnecessary movement from shelf to shelf.

A cantilever racks were proposed to the manufacturing area instead of old system with EUR-pallets storing the raw material. The racks take up 6,5 times less room and give opportunity to implement value adding activities to the floor space that is freed under the EUR-pallets.

In conclusion, the thesis has extensive role at Windak OÜ regarding the relocation project by proposing the plan of how to move and improvements for the new layout. The project is in work since April and several proposals have been put into work already (Kanban two bin system, pre-assembly stations), to reduce waste and improve the efficiency of the production.

KOKKUVÕTE

Töö eesmärk oli koostada Windak OÜ-le asendi-ning kolimisplaan, koos parendustega uues tehases. Plaanide koostamisel uuriti tootmise ning kolimisega seotud protsesside metoodikat. Firmale esitati detailne asendiplaan inventuuri paigutamiseks ning kolimisplaan, eesmärgiga teostada võimalikult sujuv ning kulusid kontrolliv kolimine.

Uue asendiplaani koostamiseks analüüsiti detailide liikumist vanas tehases, mille käigus avastatud pudelikaelasid ning kulusid eemaldati või vähendati. Uus tehas jaotati kolmeks erinevaks alaks: tootmiseks, ladustamiseks ning koostamiseks.

Tööd võib lugeda õnnestunuks, kuna Windak OÜ kasutab esitatud asendiplaani uue tehase sisustamisel. Töö tugevus seisneb esitatud muudatustes, mis muudavad protsesse tõhusamaks, ilma suurema rahalise või struktuurilise muutuseta. Windak OÜ on kasutusele võtnud ka kolimisplaan, kus on välja toodud selged ülesande kirjeldused koos vastutajatega ning ajaline graafik, hoidmaks kogu projekti kindlas ajavahemikus. Projekti plaani kasutuselevõtu eesmärk on segaduse vähendamine töötajates.

Kõige tõhusam muudatus vastavalt KPI-de analüüsile on koostu teekonna vähenemine 47,89% võrra ja ajakulu vähenemine 24,75% võrra. Seda tulemust mõjutas enim lao toomine samale korrusele, kus toimub üldine tootmine. Tagasimakse antud muudatusele on 5 kuud. Antud period näitab, et muudatus on kasumlik.

Koostamise ala põhiliseks muudatuseks oli eelkoostejaamade loomine. Jaamad loodi mehaanikutele ja elektrikutele, kelle töökohad varasemalt olid liigutatavad laudad tootmises, mis andis neile vabaduse paigutada oma töökohad eraldatud kohtadesse, tekitades hilinemisi ning puudujääke töödistsipliinis. Statsionaarsed tööjaamad loovad tööliste mugavamad töötingimused ning juhtidele parema ülevaate nende tööst, mis vähendab omakorda raiskamist.

Laos ning eelkoostejaamades vähendati raiskamist Kanban kahe konteineri süsteemi juurutamisega. Süsteem kehtib inventuurile, mille üle ladu enne kolimist detailset ülevaadet ei omanud, näiteks kinnitusvahendid. Tänu süsteemile väheneb volitamata asjade võtmine laost ning tekib jooksvalt parem ülevaade inventuurist.

Tootmisalale tehti ettepanek lisada toormaterjalide ladustamiseks konsoolriiulid, et vähendada põrandapinda. Hetkel ladustatakse toormaterjali aluste peal. Konsoolriiulid

vajavad võrreldes alustega 6,5 korda vähem põrandapinda, mida saab kasutada tulutoovamaks ettevõtmiseks.

Kokkuvõtteks saab öelda, et antud töö on mõjuv osa Windak OÜ kolimise projektis. Kasutusse minevad väljundid on asendiplaan, koos mõningaste tootmisprotsesse parendavate muudatustega, ning kolimise projekti plaan. Kolimise projekt algas juba aprillis ning Windak OÜ on alustanud parendustega (nt. Kanban kahe konteineri süsteem ja eelkoostejaamad), et vähendada raiskamist ning suurendada tootmise efektiivsust.

LIST OF REFERENCES

- [1] Windak OÜ, Majandusaasta aruanne, Tallinn, 2019
- [2] Windak Group Homepage. [WWW]
<https://www.windakgroup.com/company/about-windak/> (06.02.2020)
- [3] Electrician Supplies. [WWW]
https://www.electriciansupplies.com.au/shop/index.php?main_page=popup_image&pID=889%27 (12.03.2020)
- [4] Windak OÜ, Quality Manual, Tallinn, 2020
- [5] Willner, O., Powell, D., Gerschberger, M., Schönsleben, P. Exploring the archetypes of engineer-to-order: an empirical analysis. – International Journal of Operations & Production Management, 2016, 36 (3), 242-264
- [6] Eesti Statistika. [WWW] <https://www.stat.ee/pressiteade-2019-137> (25.02.2020)
- [7] Cheng, Y., Madsen, E. S., Liangsiri, J. Transferring knowledge in the relocation of manufacturing units. – Strategic Outsourcing An International Journal, 2010, 3(1), 5-19
- [8] Schmitt, N., Gleason, S. E., Pigom, B., Marcus, P. M. Business Climate Attitudes and Company Relocation Decisions. – Journal of Applied Psychology, 1987, 72(4), 622-628
- [9] Ferdows, K. Making the most of Foreign Factories. – Harvard Business Review, 1997
- [10] Folkestad, J. E., Johnson, R. L. Resolving the conflict between design and manufacturing: Integrated Rapid Prototyping and Rapid Tooling (IRPRT). – Journal of Industrial Technology, 2001, 17, 4, 1-7
- [11] Facilities Planning/J. A. Tompkins, J. A. White, Y. A. Bozer, J. M. A. Tanchoco. Fourth edition. John Wiley & Sons, 2010
- [12] Womack, J. P., Jones D. T. Lean Thinking: Banish Waste and Create Wealth in Your Corporation. New York: Simon & Schuster, 1996
- [13] Jones E. Quality Management for Organizations Using Lean Six Sigma Techniques. CRC Press, 2014
- [14] Douglas, A., Douglas, J., Anthony, J. Gold in the Mine: Recognising Waste in UK HEIs using Lean Thinking. – Enhancing Process Efficiency and Effectiveness in Higher Education Using Lean Six Sigma. Proceedings of First International Conference on Lean Six Sigma for Higher Education, 2013
- [15] Liker, J. K. The Toyota Way 14 Management. Principles from the World's Greatest Manufacturer. New York: McGraw-Hill, 2004
- [16] Fitz-Gibbon, C. T. Performance Indicators. – Bera dialogues, 1990, 2(2)
- [17] Marr, B. Key Performance Indicators: The 75 measures every manager needs to know. FT Publishing, 2011
- [18] Bauer, K. KPIs - The Metrics That Drive Performance Management. – DM Review, 2004, 14(9), 63-64
- [19] Masayna, V., Koronios, A., Gao, J., Gendron, M. Data quality and KPIs: A link to be established, 2007
- [20] Heragu, S. S. Facilities Design. CRC Press, 2008
- [21] Kübler. [WWW]
<https://www.kuebler.com/en/products/measurement/encoders/product-finder/product-details/5020> (04.04.2020)

- [22] Meller, R. D., Kirkizoglu, Z., Chenb, W. A New Optimization Model to Support a Bottom-up Approach to Facility Design. – *Computers and Operations Research*, 2010, 37(1)
- [23] Eurostorage. [WWW] <https://www.eurostorage.be/storage-profiles/roll-out-rack.php> (28.04.2020)
- [24] Opportunity Cost [WWW] <https://www.investopedia.com/terms/o/opportunitycost.asp> (01.05.2020)
- [25] Laomaailm [WWW] <http://laomaailm.ee/laokaup/toolaud-1500-x-750-x-850-mm-750-kg-terasplekiga-lauaplaat-perfopaneel-ja-kapp-treston/> (03.05.2020)
- [26] Monitor ERP. [WWW] <https://www.monitorerp.com/> (03.05.2020)
- [27] AJ. [WWW] <https://www.ajproducts.co.uk/warehouse-industry/workshop-industry/computer-storage-cabinets/computer-workstation/459443-19452066.wf?productId=19452064> (16.05.2020)
- [28] AM arvutimaailm. [WWW] <https://www.am.ee/Dell-Optiplex-seeria-uuendus> (16.05.2020)
- [29] Cordell, A., Thompson, I. *The Category Management Handbook*. London: Routledge, 2018
- [30] Robles, V. D. Visualizing Certainty: What the Cultural History of the Gantt Chart Teaches Technical and Professional. *Communicators about Management*. – *Technical Communication Quarterly*, 2018, 27(4), 300-321
- [31] Payback Period. [WWW] <https://www.investopedia.com/terms/p/paybackperiod.asp> (24.05.2020)
- [32] Eesti Statistika – Salary info. [WWW] <https://www.palgad.ee/salaryinfo> (06.04.2020)

APPENDICES

Appendix 1 Windak part codes

Code	Description	Code	Description
21	Cut, drilled	43	Linear guides
22	Turned, milled	44	Keys
23	Welding	45	Belts
24	Welding, combination	46	Bumpers
25	Treated std part	47	Gearboxes
26	Plastic	80	Sensors, cables
27	Aluminium	81	Cables
28	Stainless	82	Connectors
29	Rubber	83	Servo drives, frequency inverters
40	Rollers, clutches, breaks, wheels	84	Electrical buttons
41	Fasteners	85	Air conditioners
42	Pneumatics	86	Electrical motors

Appendix 2 Windak BOM for 02-4005-B2 Length counter



Part no.	Name	Revision
02-4005-B2	Lenght counter, 5000 p 5V DC	

Material... [02-4005-B2]

Pos.no.	Part no.	Name	Quantity	Unit	Rev.	Supplier's part name
010	20-078729-1	Stand	1,0	pcs		
020	20-056268-1	Housing	1,0	pcs		
030	41-106045	Socket Head Cap Screw	3,0	pcs		DIN912 M6X45
040	43-003215	Ball Bearing	2,0	pcs		6002 2Z/C3
050	20-056270	Shaft	1,0	pcs		
060	44-910015	Circlip, Shaft	2,0	pcs		SGA15
070	44-920032	Circlip, Hole	1,0	pcs		SGH32
080	81-000345	Sensor, Pulse, 5000 pulses 5V	1,0	pcs		Sendix 5020, 8.5020.8842.5000
090	81-000681	Cable,M12 Female, SH,PUR,8>	1,0	pcs		1522901/PUR/20
100	41-104010	Socket Head Cap Screw	2,0	pcs		DIN 912 M4X10
110	20-056271	Bush	1,0	pcs		
120	20-022000	Wheel	1,0	pcs		
130	40-000080	Tensioner element	1,0	pcs		CN 25 15X25
140	43-000401	INA Carriage 25	1,0	pcs		KWVE25-b
150	41-108016	Socket Head Cap Screw	4,0	pcs		DIN912 M8X16
160	20-056272	Linear guide INA	1,0	pcs		
170	20-036661	Shaft	1,0	pcs		
180	20-022001	Wheel	1,0	pcs		
190	43-003215	Ball Bearing	2,0	pcs		6002 2Z/C3
200	41-710010	Washer	1,0	pcs		DIN 125 10,5X21X2
210	41-110050	Socket Head Cap Screw	1,0	pcs		DIN912 M10X50
220	20-021884	Shaft	1,0	pcs		22-021884
230	44-950053	Spring, push	1,0	pcs		1553
240	20-021883	Screw	1,0	pcs		22-021883
250	41-630020	Nut, low	2,0	pcs		DIN936 M20
260	20-071555	Bracket	1,0	pcs		
270	41-108020	Socket Head Cap Screw	2,0	pcs		DIN912 M8X20
280	41-610008	Locking nut	2,0	pcs		DIN985 M8
290	20-080256	Wheel	1,0	pcs		
300	43-018016	Ball bearing	1,0	pcs		3201 A-2ZTN9/MT33
310	44-920032	Circlip, Hole	2,0	pcs		SGH32
320	20-071557	Bushing	1,0	pcs		
330	41-112050	Socket Head Cap Screw	1,0	pcs		DIN912 M12X50
340	41-610012	Locking nut	1,0	pcs		DIN985 M12
345	20-085089	Plate	1,0	pcs		
350	20-085091	Plate	1,0	pcs		
360	41-710008	Washer	2,0	pcs		0407-8
370	41-108040	Socket Head Cap Screw	2,0	pcs		DIN912 M8X40
380	41-610008	Locking nut	2,0	pcs		DIN985 M8
390	40-000527	Roller, Adjustable, left	1,0	pcs		3-400282-02/1297
400	41-906020	Socket Head Cap Screw Low h	4,0	pcs		DIN7984 M6x20

Appendix 3 Duration of relocation project

Title	Start date	Due date	Duration
Relocation	4/1/2020	8/31/2020	152 days
1. Planning	4/1/2020	7/7/2020	70 days
1.1 Creating a team	4/1/2020	4/3/2020	3 days
1.2 Creating a budget	4/6/2020	4/8/2020	3 days
1.3 Creating a production plan	4/6/2020	4/17/2020	10 days
1.4 Creating a new factory layout	6/5/2020	6/29/2020	17 days
1.4.1 Marking the layout	6/25/2020	6/29/2020	3 days
1.5 Creating a transport plan	6/30/2020	7/7/2020	6 days
2. Sorting	5/11/2020	7/10/2020	45 days
2.1 Sorting execution	5/11/2020	6/19/2020	30 days
2.2 Selling/scrapping old equipment	6/1/2020	7/10/2020	30 days
3. Transport of inventory	7/1/2020	7/31/2020	23 days
3.1 Setting up new inventory	7/1/2020	7/7/2020	5 days
3.2 Moving warehouse shelves	7/8/2020	7/10/2020	3 days
3.3 Moving manufacturing machines	7/13/2020	7/13/2020	1 day
3.4 Moving raw material warehouse	7/14/2020	7/14/2020	1 day
3.5 Moving test material	7/15/2020	7/15/2020	1 day
3.6 Moving warehouse inventory	7/16/2020	7/17/2020	2 days
3.7 Moving pre-assemblies and fasteners	7/20/2020	7/24/2020	5 days
3.8 Moving main assemblies	7/27/2020	7/29/2020	3 days
3.9 Moving office area	7/30/2020	7/31/2020	2 days
4. Finalising the project	8/10/2020	8/31/2020	16 days
4.1 Inventory execution	8/10/2020	8/14/2020	5 days
4.2 Test run	8/17/2020	8/28/2020	10 days
4.3 Launch		8/31/2020	
Total: 24 tasks			

Appendix 4 Windak OÜ company structure

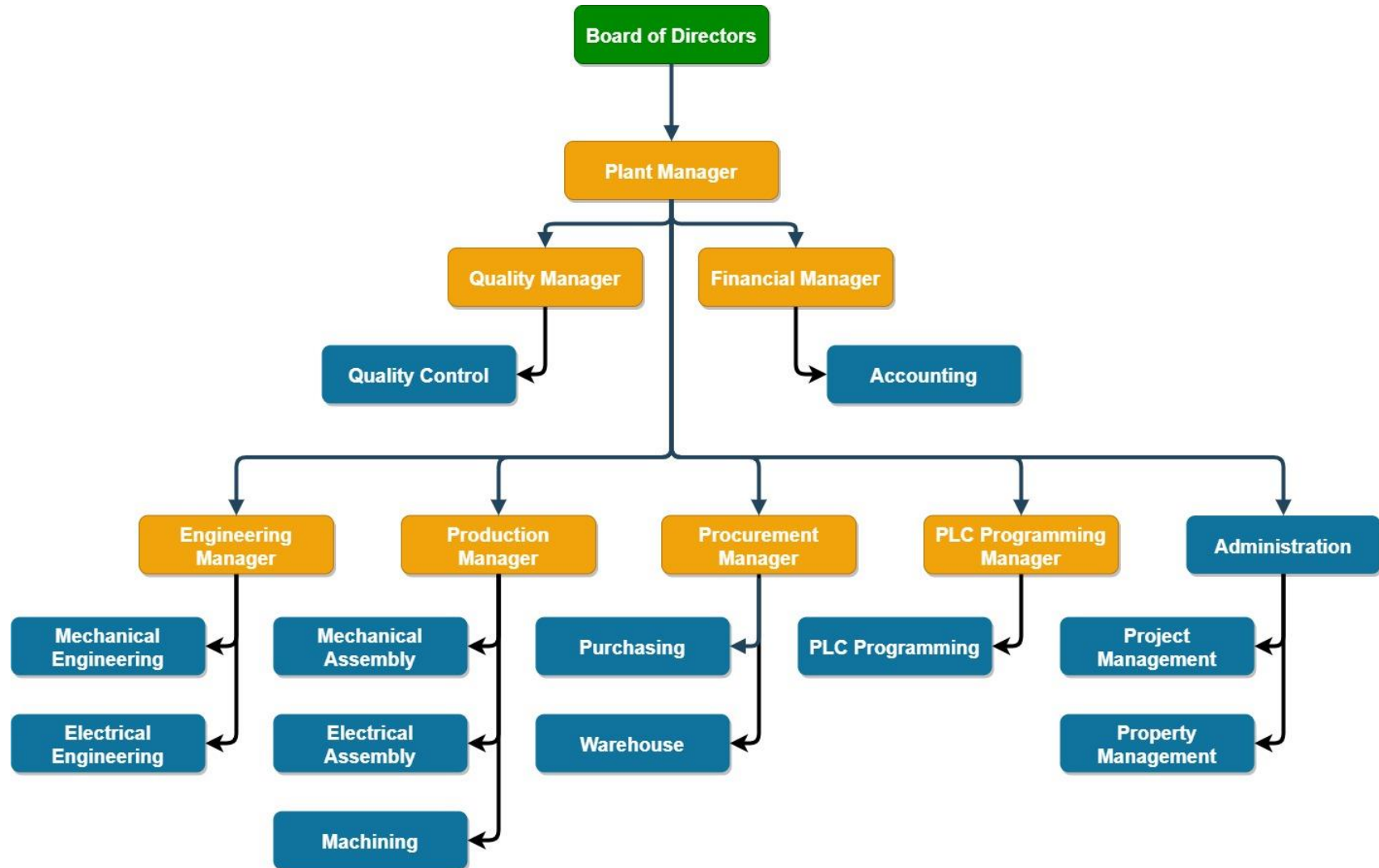

Appendix 5 Total cost for work calculations

Title	Start date	Due date	Duration	Responsible	Work load	Ppl	Responsible	Work load	Ppl	Responsible	Work load	Ppl	Cost	Hours
Relocation	4/1/2020	8/31/2020	152 days											
1. Planning	4/1/2020	7/7/2020	70 days											
1.1 Creating a team	4/1/2020	4/3/2020	3 days	Plant manager	100%	1							385.95	24.00
1.2 Creating a budget	4/6/2020	4/8/2020	3 days	Plant manager	100%	1	Financial manager	100%	1				787.75	48.00
1.3 Creating a production plan	4/6/2020	4/17/2020	10 days	Production manager	50%	1							643.24	40.00
1.4 Creating a new factory layout	6/5/2020	6/29/2020	17 days	Property manager	50%	1							736.97	68.00
1.4.1 Marking the layout	6/25/2020	6/29/2020	3 days	Property manager	100%	1	Transport workers	100%	4				1,324.23	120.00
1.5 Creating a transport plan	6/30/2020	7/7/2020	6 days	Procurement manager	80%	1	Property manager	40%	1	Production manager	20%	1	979.98	67.20
2. Sorting	5/11/2020	7/10/2020	45 days											0.00
2.1 Sorting execution	5/11/2020	6/19/2020	30 days	Procurement manager	20%	1	Warehouse workers	40%	2				2,557.32	240.00
2.2 Selling/scrapping old equipment	6/1/2020	7/10/2020	30 days	Procurement manager	100%	1							3,859.46	240.00
3. Transport of inventory	7/1/2020	7/31/2020	23 days											0.00
3.1 Setting up new inventory	7/1/2020	7/7/2020	5 days	Property manager	100%	1	Transport workers	100%	4				2,207.04	200.00
3.2 Moving warehouse shelves	7/8/2020	7/10/2020	3 days	Property manager	100%	1	Transport workers	100%	4	Warehouse workers	20%	2	1,413.50	129.60
3.3 Moving manufacturing machines	7/13/2020	7/13/2020	1 day	Property manager	100%	1	Transport workers	100%	4	Operators	100%	2	441.41	56.00
3.4 Moving raw material warehouse	7/14/2020	7/14/2020	1 day	Property manager	100%	1	Transport workers	100%	4	Warehouse workers	20%	2	471.17	43.20
3.5 Moving test material	7/15/2020	7/15/2020	1 day	Property manager	100%	1	Transport workers	100%	4	Warehouse workers	20%	2	471.17	43.20
3.6 Moving warehouse inventory	7/16/2020	7/17/2020	2 days	Property manager	100%	1	Transport workers	100%	4	Warehouse workers	100%	2	1,180.39	112.00
3.7 Moving pre-assemblies and fasteners	7/20/2020	7/24/2020	5 days	Property manager	100%	1	Transport workers	100%	4	Assembly workers	100%	10	5,424.94	600.00
3.8 Moving main assemblies	7/27/2020	7/29/2020	3 days	Property manager	100%	1	Transport workers	100%	4	Assembly workers	100%	10	5,342.25	360.00
3.9 Moving office area	7/30/2020	7/31/2020	2 days	Property manager	100%	1	Transport workers	100%	4	Office workers	100%	17	5,213.65	352.00
4. Finalising the project	8/10/2020	8/31/2020	16 days											0.00
4.1 Inventory execution	8/10/2020	8/14/2020	5 days	Procurement manager	50%	1	Warehouse workers	100%	2				321.62	100.00
4.2 Test run	8/17/2020	8/28/2020	10 days	Eveybody	25%	40							2,622.23	800.00
4.3 Launch		8/31/2020	1 day	Everybody	25%	40							262.22	80.00
Total: 24 tasks													Total:	36,646.47 3,723.20

Title	People	Average cost per hour	Bruto
Assembly workers	10	8.04	962.00
Financial manager	1	16.74	2002.00
Office workers	17	15.92	1904.00
Operators	2	10.94	1308.00
Plant manager	1	16.08	1923.00
Procurement manager	1	16.08	1923.00
Production manager	1	16.08	1923.00
Property manager	1	10.84	1296.00
Transport workers	4	11.08	1315.50
Warehouse workers	2	9.30	1112.00
Total:	40	131.11	
Average cost per hour		12.79	

*Average cost per hour is taken from Estonian Statistics. [32]

GRAPHICAL MATERIALS