



TALLINN UNIVERSITY OF TECHNOLOGY
SCHOOL OF ENGINEERING
Department of Mechanical and Industrial Engineering

**INTEGRATION OF LEAN PRINCIPLES FOR THE
SURFACE TREATMENT PROCESS IMPROVEMENT:
A CASE STUDY OF AQ LASERTOOL OÜ**

**LEAN-PRINTSIIPIDE JUURUTAMINE
PINNAKATMISE PROTSESSIDE JAOKS:
JUHTUMIUURING AQ LASERTOOL OÜ NÄITEL**

MASTER THESIS

Student: Jan Golõnski

Student code: 204695MARM

Supervisor: Kashif Mahmood, researcher

Tallinn 2022

(On the reverse side of title page)

AUTHOR'S DECLARATION

Hereby I declare, that I have written this thesis independently.
No academic degree has been applied for based on this material. All works, major viewpoints and data of the other authors used in this thesis have been referenced.

"30" December 2022

Author: Jan Golõnski
/signed digitally/

Thesis is in accordance with terms and requirements

"30" December 2022

Supervisor: Kashif Mahmood
/signed digitally/

Accepted for defence

"30" December 2022

Chairman of theses defence commission: Kristo Karjust
/signed digitally/

Non-exclusive licence for reproduction and publication of a graduation thesis¹

I, Jan Golõnski (date of birth: 31.12.1995) hereby

1. grant Tallinn University of Technology non-exclusive licence for my thesis "Integration of the lean principles for the surface treatment processes improvement",

supervised by Kashif Mahmood,

1.1 to be reproduced for the purposes of preservation and electronic publication of the graduation thesis, incl. to be entered in the digital collection of the library of Tallinn University of Technology until expiry of the term of copyright;

1.2 to be published via the web of Tallinn University of Technology, incl. to be entered in the digital collection of the library of Tallinn University of Technology until expiry of the term of copyright.

2. I am aware that the author also retains the rights specified in clause 1 of the non-exclusive licence.

3. I confirm that granting the non-exclusive licence does not infringe other persons' intellectual property rights, the rights arising from the Personal Data Protection Act or rights arising from other legislation.

29.12.2022

/Signed digitally/

¹ *The non-exclusive licence is not valid during the validity of access restriction indicated in the student's application for restriction on access to the graduation thesis that has been signed by the school's dean, except in case of the university's right to reproduce the thesis for preservation purposes only. If a graduation thesis is based on the joint creative activity of two or more persons and the co-author(s) has/have not granted, by the set deadline, the student defending his/her graduation thesis consent to reproduce and publish the graduation thesis in compliance with clauses 1.1 and 1.2 of the non-exclusive licence, the non-exclusive license shall not be valid for the period.*

Department of Mechanical and Industrial Engineering

THESIS TASK

Student: Jan Golõnski, 204695MARM

Study programme: MARM06/18, Industrial Engineering and Management

Supervisor: Reseacher, Kashif Mahmood, +372 58254893

Thesis topic: Integration of lean principles for the surface treatment process

improvement: a case study of AQ Lasertool OÜ

Lean-printsiiptide juurutamine pinnakatmise protsesside jaoks: juhtumiuuring AQ

Lasertool OÜ näitel

Thesis main objectives:

1. To define the main bottlenecks in surface treatment processes
2. To find Lean solutions to evade the bottleneck or minimize the effect of it.
3. To analyze the surface treatment process based on Lean tools and techniques.
4. To implement Lean tools for the processes improvement to keep solutions working.

Thesis tasks and time schedule:

No	Task description	Deadline
1.	Overview of the company and surface treatment processes	17.11.2022
2.	Lean principles and methods overview	23.11.2022
3.	Analysis of KPI-s and lean solutions selection for optimization	28.12.2022
4.	Feedback of the implemented solutions and calculations	28.12.2022
5.	Summary	28.12.2022

Language: English **Deadline for submission of thesis:** "30" December 2022

Student: Jan Golõnski (signed digitally) "29" December 2022

Supervisor: Kashif Mahmood (signed digitally) "30" December 2022

Head of study programme: Kristo Karjust (signed digitally) "30" December 2022

Terms of thesis closed defence and/or restricted access conditions to be formulated on the reverse side

CONTENTS

PREFACE	6
List of abbreviations and symbols	7
INTRODUCTION.....	9
1. OVERVIEW OF THE COMPANY	10
1.1 Overview of AQ Lasertool OÜ	13
2. LEAN INTEGRATION.....	16
2.1 Lean principles and techniques	16
2.2 Tools of implementation	18
2.2.1 VSM tool	19
2.2.2 Error proofing tool (Poka-yoke tool).....	24
3. PRODUCTION PROCESSES AND BOTTLENECKS	26
3.1 Overview of processes in Viimsi production plant	26
3.1.1 Pre-production and control processes.....	28
3.1.2 ED and powder coating processes.....	32
3.1.3 Assembly and packing processes.....	36
3.2 Bottlenecks	39
3.3 Key Performance Indicators	42
4. CASE STUDY OF SURFACE TREATMENT PROCESSES	43
4.1 VSM analysis	43
4.2 Lean solutions and their implementation.....	46
4.3 Calculation and KPI analysis.....	54
SUMMARY.....	57
KOKKUVÕTE	58
LIST OF REFERENCES	59
APPENDICES	61
GRAPHICAL MATERIAL	65

PREFACE

Jan Golõnski, who works as a product engineer in company AQ Lasertool Viimsi, initiated the master thesis "Integration of the lean principles for surface treatment on the example of AQ Lasertool Viimsi.

AQ Lasertool Viimsi is filial of the AQ Lasertool OÜ, which is the part of the AQ Group concern, AQ Lasertool Viimsi was integrated into the concern in 2014. The production facility is needed to be upgraded due to increased orders from the main customers that have troubles with downtime due to COVID-19 pandemic, heavily increased energy, and gas prices.

Author of the thesis would like to thank the supervisor Kashif Mahmood for his continuous support by providing feedback during thesis preparation and final writing.

Keywords: Lean principles, Surface treatment process, Process improvement, Causes and solutions, Master thesis

List of abbreviations and symbols

AQ – Aros Quality

SEK – Swedish krona

EBT – Earnings before tax

EBIT – Earning before interest and tax

CE – construction equipment

QMS – Quality Management System

HR - Human Resources

RFQ – Request for Quotation

PPAP – Production part approval process

PSW – Part Submission Warrant

ERP – Enterprise Resource Planning

FMF – Foleshill Metal Finishing

BOM – Bill of Material

ED – electrodeposition

PREP – preparation

PVR – Part Version Report

µm – micron (0,001 mm)

PCO – powder curing oven

CTT – curing temperature test

ZnPh – Zinc-phosphate

Kaizen – continuous improvement

JIT – Just In Time

TPS – Toyota Production System

VSM – Value Stream Mapping

IT – Information technologies

FIFO – First in, First Out

PCS – pieces

wk - week

INTRODUCTION

Recent situation in production filed shows to us that companies need to adapt as soon as possible due to increased risks of deficit of energy resources, unpredictable limitation of human resources and logistics complications. AQ Lasertool Viimsi has been facing them during the last 2 years and made sufficient progress how to evade or confront these kinds of risks. The motivation to choose AQ Lasertool Viimsi and write the master thesis is going to show what lean methods are in use to evade these risks or minimize the major consequences from them.

The main idea of the thesis is to analyse how does the company provide the implementation of lean principles to the production processes: from price calculations till packaging of finished goods, and show the results of the lean integration. The other aspect of the thesis relates us to make sure, what is lean and why does it need in our days.

The motivation of further lean integration also came after the Covid-19 pandemic and energy crisis. It has seriously affected the production costs and capacities by increasing utility costs and downtime, but also decreasing the human resources at some time.

The first chapter introduces the overview of company: business areas, goals, business concepts, management, main clients and revenues. The second chapter meets further with the AQ Lasertool Viimsi surface treatment processes and its problems that have possibility to occur. Next chapters explain the methodological part of lean integration for surface treatment processes and the analysis how to optimize them wisely: initial stages, key performance indicators, elimination of the bottlenecks and solutions.

1. OVERVIEW OF THE COMPANY

AQ Group AB was established in 1994 as a Aros Quality Group through the merger of ABB Industrial Systems transformer division and ABB Relays accessories section. The entire concern divided into two main segments: system and components. Concern has approximately 6500 employees in 16 countries. The list of countries: Brazil, Bulgaria, Canada, China, Estonia, Finland, Germany, Hon Kong, Hungary, India, Italy, Lithuania, Mexico, Poland, Sweden, USA. Annual turnover is about €520 millions. [1]

System segments include bussines areas that are related with electric cabinets (Figure 1.1) and system products (Figure 1.2). The examples of system products: ticket machines for parking lots and airports, automatic teller machines, packaging machines, printers and passport automation systems. [2]



Figure 1.1: Electric cabinets [2]



Figure 1.2: System product (automatic teller machine) [2]

Component segments include bussines areas that involve: [2]

- injection molding (thermoplastic components);
- inductive components (transformers, inductors, coils, chokes, reactors etc.);
- wiring systems (wiring harness systems and electromechanical modules);
- sheet metal processing (sheet metal components and sheet metal assemblies);
- special technology and engineering (product development and implementation).



Figure 1.3: Inductive components [2]



Figure 1.4: Wiring systems [2]



Figure 1.5: Sheet metal products [2]

Core values of the concern are: [3]

- customer focus;
- simplicity;
- entrepreneurial business;
- cost efficiency;
- courage and respect.

Value of customer focus explains as being a long-term partner and supplier to the customers. Value of simplicity refers as making production processes easier to understand and more efficient to decrease the downtime. Entrepreneurial business represents as a competent supplier in their field that always ready for continuous improvements and being independent from the creditors. Cost efficiency value explained as a wise use of resources such as time, finances and connections. The last value represents as not only being ready for the changes, but also making crucial decisions.

Figure 1.8 shows the graph the financial development of AQ Group since its establishment in 1994. [4]

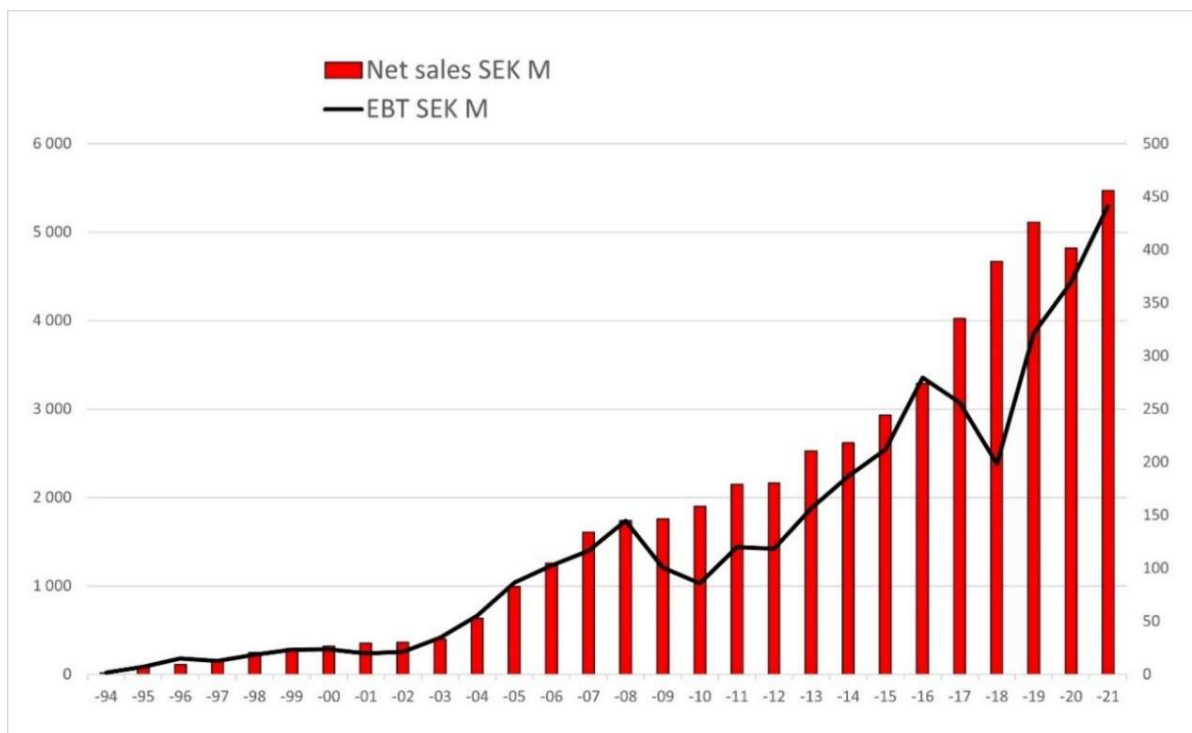


Figure 1.6: Financial development of the AQ Group AB [4]

Table 1.1 shows the last 5 years of the annual revenue and operating profit (EBIT) that were financially documented.

Table 1.1: AQ Group AB annual revenue and operating profit [4]

Year	Annual revenue (SEK)	Operating profit (SEK)
2021	5 471 000	446 000
2020	4 819 000	401 000
2019	5 113 000	340 000
2018	4 667 000	208 000
2017	4 020 000	263 000

1.1 Overview of AQ Lasertool OÜ

AQ Lasertool OÜ mostly related with sheet metal processing, commonly with sheet metal components for automotive, locomotive industries. Such as spare parts for public transport, track-bound traffic, trucks, construction machinery, forestry and agriculture equipment.

AQ Lasertool OÜ main production facilities:

- Pärnu (10 000 m²);
- Jüri (4 000 m²);
- Viimsi (2 500 m²).

AQ Lasertool Viimsi is a part of AQ Lasertool OÜ company, which was integrated in 2014. Production site located at Vanapere tee 8 in Pringi county, Harjumaa, Estonia.



Production capacity is 2500 m² and main production processes related with surface treatment: ED-coat and powder coating. In addition, there is also a possibility to assembly processes. [1]



Figure 1.8: AQ Lasertool Viimsi production facility

Main clients for the Viimsi department mostly related to the automotive industry: trucks, buses, construction equipment, forest equipment. These clients are Volvo Group, Scania, Man. Table 1.2 shows examples of finished products, which parts going to be in use after ED and powder coating processes at Viimsi plant.

Table 1.2: Main customers of AQ Lasertool OÜ [5], [6], [7]

Customer	Field of Industry	Visual example
Volvo	automotive, construction equipment, forest equipment	
Scania	automotive	
MAN	automotive	

The main lead at Viimsi production unit is in hands of production unit manager, who also cooperates with the Lagre production unit, who is in charge of QMS, finances, human resources, purchase, logistics, administration. Figure 1.15 shows the structure of AQ Lasertool Viimsi management. Table 1.3 shows the main responsibilities of each position.

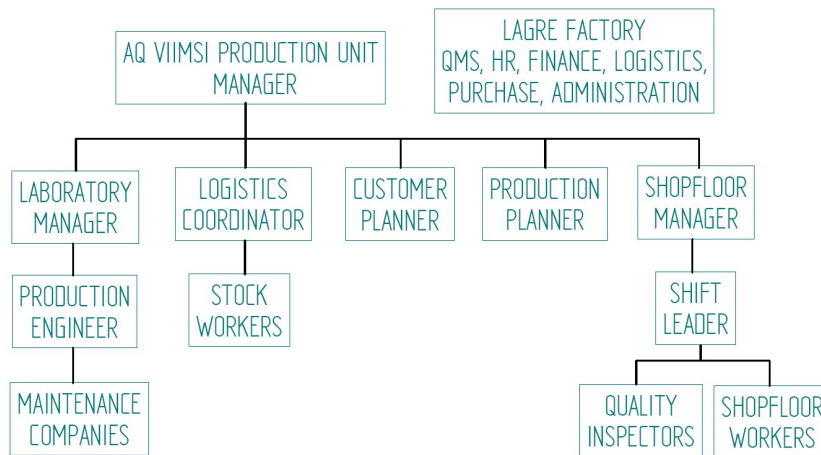


Figure 1.9: Management structure of Viimsi production unit

Table 1.3: The list of position and their main responsibilities

	Position	Responsibilities
1.	Production Manager	Labour resources allocation, production schedules tracking, cost adjustments
2.	Laboratory Manager	Supervision of laboratory tests to make sure that processes and products meet the standards and safety regulations
3.	Logistics Coordinator	Ensuring the material flow of raw material from suppliers and final goods to customers
4.	Customer Planner	Registration of the new customers, orders registration and approval
5.	Production Planner	Production schedule planning, colour change and their priority evaluation
6.	Shopfloor Manager	Shopfloor staff management
7.	Production Engineer	RFQ calculation, work instructions creation and optimization, new products integration, preparations organization
8.	Shift Leader	Direct supervision of shopfloor workers
9.	Stock Workers	Responsible for packing materials and methods that answer customer's needs
10.	Quality Inspectors	Direct quality control of the coated products
11.	Shopfloor Workers	Products hanging, demagnetisation, masking, powder coating, pre-packing

2. LEAN INTEGRATION

Lean production is method of production that involves such designs or paths of approaches that supplier can maximize the potential gains and customer value while decreasing the wastes without increasing the price. Main purposes of lean methods integration are to increase and hold the decent quality of final product, reduce lead times and production costs, relies on the collaboration. [8]

2.1 Lean principles and techniques

Lean principles were created for the knowledge of working and management to encourage the practice of improvement implementation, respect worker's labour and increase customer's value. First main principles as shown in Fig 2.1 came from TPS that include value definition, value stream mapping, flow creation, pull establishment and pursuit of perfection. [8]

Value definition needs to understand what kind of value customer ready to pay for and does it covers the needs. Value stream mapping means to point out, which necessary processes push forward to the value. Also, what kinds of processes tangle the path towards it, but necessary and which processes should be eliminated.

Flow creation means to make sure that path is smooth enough and without any delays for the value adding processes. Pull establishment is needed to take inventory under control, which means that the information and materials are ready to use at the right time. Pursuit of perfection develops the culture of continuous improvement, which means that senior and junior staff will be encouraged to get the best value.



Figure 2.1: Circulation of the lean principles [9]

To implement all these principles to the practice, people need to use specific techniques that were created especially for the lean production management. Technique is a skill or procedure that needed to use to complete the task or resolve the problem.

Main techniques of lean production: [10]

- continuous improvement;
- elimination of wastes;
- organization of the workplace;
- maintainability and reconfigurability.

Continuous improvement is a never-ending perfection of the product, process or their combination. This kind of principle helps not to stagnate or downgrade the quality of final product or entire production process.



Figure 2.2: Definition of the Kaizen [11]

Kaizen means continuous improvement as defined in the Figure 2.2, which also means continuous approach (Figure 2.3) of small changes with positive effects that based on cooperation and commitment between senior and junior staff to lower defects, boost productivity, promote innovation, encourage shopfloor operator purpose and eliminate wastes. It stays in belief that everything can be improved by identifying issues and finding or creating solutions, testing and implementing them into the process. [10]



Figure 2.3: Kaizen steps for continuous improvement [12]

Elimination of wastes is a principle of eliminating all kinds of things that do not add value to the customer. Main wastes divide into waiting, over-processing, over-production, defects, motion, inventory, and unnecessary transportation. [10]



Figure 2.4: 7 wastes of lean production [13]



Figure 2.5: 5S diagram [15]

Organization of the workplace enables ease of access for the workers, keeps the workplace clean, improves the ergonomics to make processes smoother and keeps workplace safe for the users. [16]

Maintainability and reconfigurability are these aspects that measure the ability of retain, restore the equipment and reconfigure to those settings that will be more suitable and effective for the production. [16]

2.2 Tools of implementation

Implementation happens by using lean tools that reduce wastes and increase the quality by eliminating unvaluable processes. Main lean tools that are going to be in use: Value Stream Mapping and error proofing.

2.2.1 VSM tool

VSM visualizes production steps, their tasks, lead time and material consumption. It helps to find the processes that have less value and should be deleted, also processes can be added to increase the value. VSM mainly used in such fields like manufacturing, logistics, healthcare, administration, IT. [20]

Main benefit of using Value Stream Mapping tool is an ease of visualization and understanding. You can clearly visualize the process, its timings and materials, where the waste has a possibility to occur. [20]

List of wastes that can be found with the help of VSM: [20]

- inventory issues and constraints (lack or excess of inventory)
- timing issues and constraints (process delays, excessive downtime)

There are two kinds of VSM visualizations that need to be issued. Firstly, the current state map that shows processes, methods, timings and inventory that company uses for production. Secondly, the future state map that shows the improved version of production with eliminated or less influential wastes, decreased downtimes or increased quality of the product.

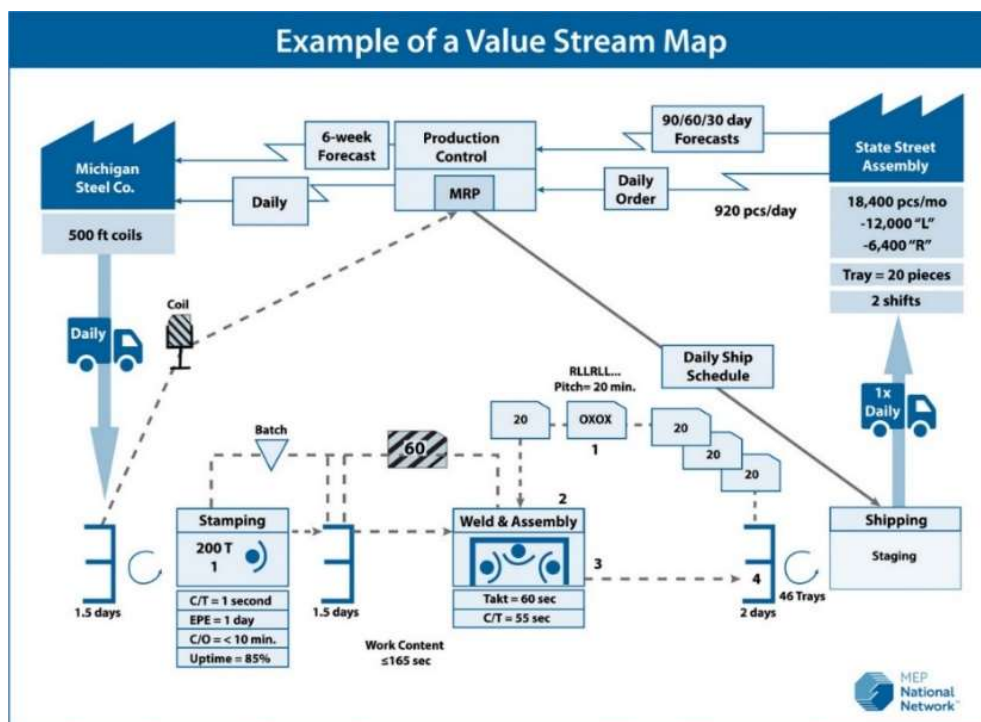


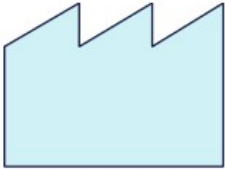

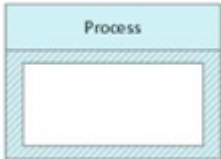
Figure 2.6: Example of VSM visualization [21]

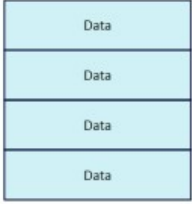
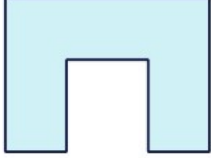
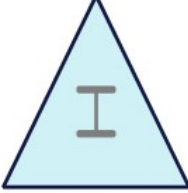


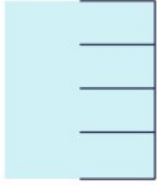


Main steps of Value Stream Mapping: [22]

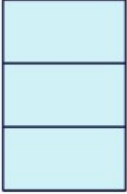
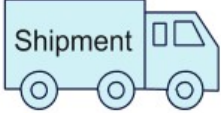
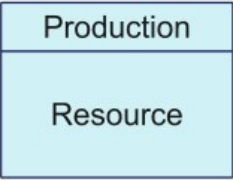





- Scoping out the Value Stream Map;
- Process family determination;
- Identification of similarities;
- Creation of VSM template;
- Creation of Current State Map;
- Creation of Future State Map;
- Creation of VSM Draft Plan.


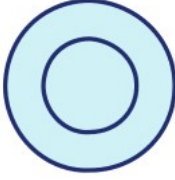

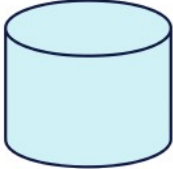

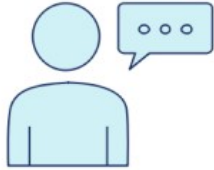
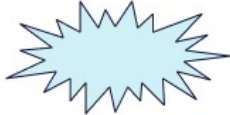

Table 2.1 shows the symbols that usually used for creation of current and future state maps.

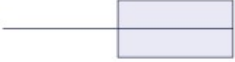
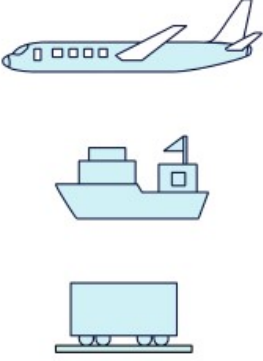
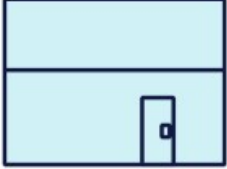
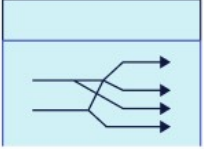

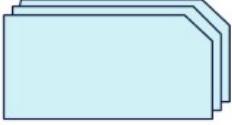
Table 2.1: Symbols of VSM [23]

Name of Symbol	Description	Symbol Visualization
Customer/Supplier	Supplier (upper left corner) and customer (upper right corner)	
Dedicated Process Flow	Fixed and continuous internal material flow through a department, process, operation or machine	
Shared Process	Process, operation, work center that shared by other stream value families	

<p>Databox</p>	<p>Significant data. Usually placed under the symbols that own this data.</p>	
<p>Work cell</p>	<p>Shows an integration of multiple processes into one work cell.</p>	
<p>Inventory</p>	<p>Stored inventory or inventory between processes.</p>	
<p>Shipment</p>	<p>Raw materials shifting the supplier to the plant. Delivery of final products from plant to the customer.</p>	
<p>Push Arrow</p>	<p>Journey of material from one process to another one.</p>	
<p>Kanban Stock Point (Supermarket)</p>	<p>Shows where the downstream customers can get the inventory they need as the supplier provides it.</p>	
<p>Material Pull</p>	<p>Used when Kanban Stock Points connect to downstream processes for physical removing of the materials.</p>	
<p>FIFO Lane</p>	<p>First-In-First-Out system,</p>	

Safety Stock	Emergency stock to protect the system in case of possible failures.	
External Shipment	Shipment of raw materials from the supplier or finished goods to the customer.	
Production Control	Central production scheduling or control department.	
Manual Info	General information from memos, reports etc.	
Electronic Info	Digital information from the Internet, Intranet and other servers.	
Production Kanban	Production needs to supply parts to customers	
Withdrawal Kanban	Card that instructs the operator to move a product from stock point to a process.	
Signal Kanban	Shows that inventory levels have dropped to a minimum in a stock point. Also, it signals the production for the receiving process.	

<p>Kanban Post</p>	<p>Used near stock points to show the location for collecting Kanban signals.</p>	
<p>Sequenced Pull</p>	<p>Offers instructions to processes to manufacture a required product. Also eliminates the need for stock point storage.</p>	
<p>Load Leveling</p>	<p>Used to batch Kanbans to level the production volume</p>	
<p>MRP/ERP</p>	<p>Inventory scheduling</p>	
<p>Go See</p>	<p>Visual observation by the supervisor</p>	
<p>Verbal Information</p>	<p>Verbal and personal information</p>	
<p>Kaizen Burst</p>	<p>Highlights the problem areas to solve the problem with intercity and urgency</p>	
<p>Other Information</p>	<p>Useful information</p>	

Timeline	Shows waiting and processing times. Helps with calculation of lead time and total cycle time.	
Transportation	Shows the type of transportation	
Warehouse	Shows internal or external warehouse	
Cross-Dock	Shows supply chain that eliminate the need of warehouse. Materials go from inbound to outbound transport.	
Phone	Communication by phone or phone orders	
Batched Kanban	Kanban cards arriving or being sent in batches	

2.2.2 Error proofing tool (Poka-yoke tool)

Error proofing involves the methods that make processes mostly impossible to mistake or fast to correct them. It helps to find and prevent the errors that have been occurred in production processes. Their implementation should strengthen quality and safety, increase the value for the customer. [24], [25]

Main steps of error proofing tool implementation: [24], [25]

- Flowchart creation;
- Error source searching in the processes;
- Error proofing solution analysis (minimization, prevention, replacement or elimination);
- Decision making;
- Inspection method choosing (self-inspection, successive inspection or source inspection).

In addition, there are two types of functions that must be added during error proofing implementation. Firstly, setting functions that establish parameters or attributes for error inspection. Secondly, regulatory functions (signals) that alert workers if error has occurred. Setting functions divide into contact, motion-step, fixed-value or information enhancement. Regulatory functions divide into warning and control ones.

3. PRODUCTION PROCESSES AND BOTTLENECKS

Surface treatment is a process applied to the surface of the material to increase the durability, corrosion resistance and visual appearance of the object.

Surface treatment includes the sufficient amount of processes that need to follow to achieve the final product that meets customer needs and to lower the negative affects to the production, people and environment. These affects cause additional production costs like materials, equipment, utilities, maintenance, sick pays, downtimes.

3.1 Overview of processes in Viimsi production plant

Viimsi production processes consist of:

- RFQ;
- raw material control;
- demagnetization;
- hanging for ED and powder line;
- masking before ED and powder line;
- ED coating;
- quality control for coated parts;
- powder coating;
- assembly;
- packing.

AQ Lasertool OÜ uses Monitor ERP programm that include such types of information like BOM, process steps and timings, customer info, supplier info, planning, price calculation and technical documentation. The benefit of this programm is its versatility that means less paperwork and faster information flow with more detailed intel.

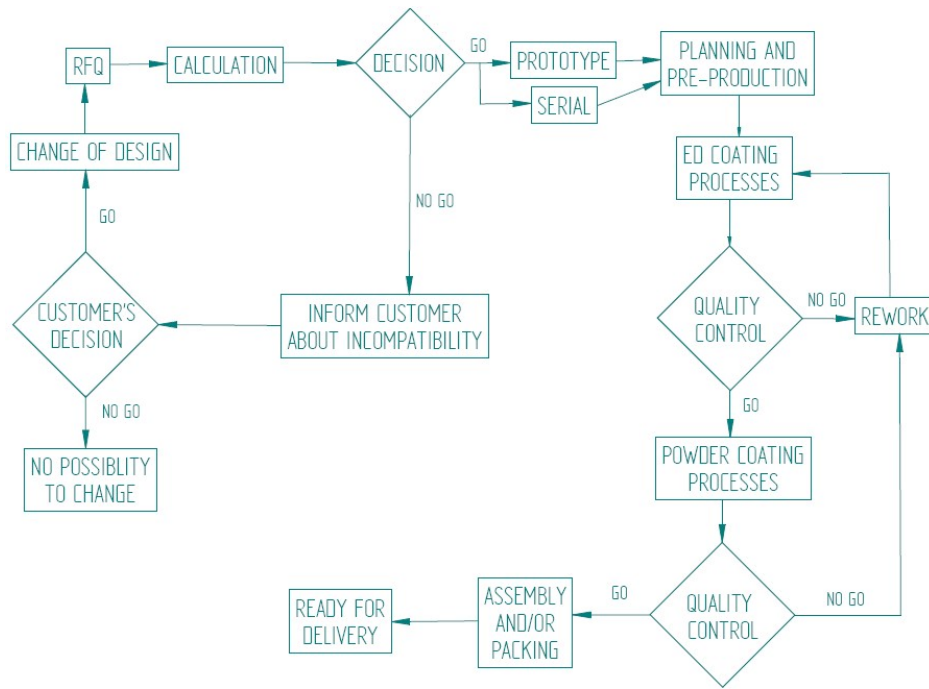


Figure 3.1: Production flowchart

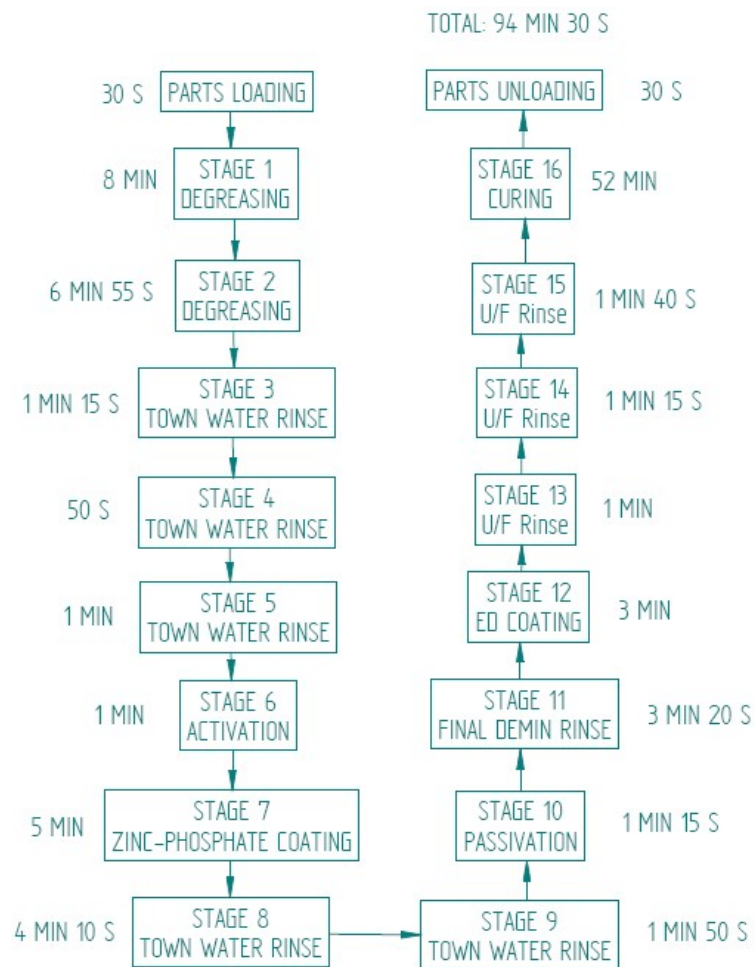


Figure 3.2: ED coating flowchart with timings

3.1.1 Pre-production and control processes

RFQ or request for quotation is a calculation process for production that includes all possible costs that are going to be used for: purchased material, special equipment and lead time. Also it includes a margin that describes like an exact percent of each part that is going to be coated. During the RFQ customer sends all crucial documents: drawings, 3D-models, PVR and annual amount of the part article and/or batch quantities.

Each significant stage of the surface treatment process goes through the quality control. Quality control process consists of visual control and the coated part must meet the customer standards. There is also a defect catalogue of each significant stage (raw material, ED and powder coated parts) that shows possible defects that can occur during the production processes.



Figure 3.3: Example of the failure catalogue

Demagnetization is a process during which metal parts are going through the demagnetization tunnel that removes undesirable magnetism that affects the quality on ED line. Tunnel creates counter-magnet field that neutralizes the magnet field on the part. Figure 2.3 shows the defect that can occur after ED coating without the demagnetization process. [26]

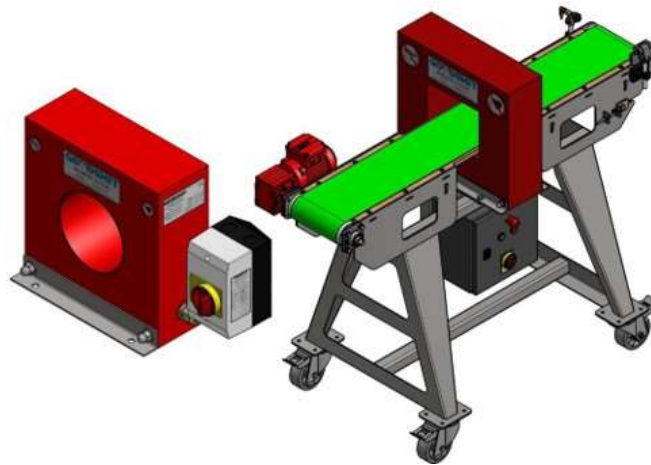


Figure 3.4: Gouldsmith demagnetization tunnel [31]



Figure 3.5: Sharp edges on undemagnetized surfaces after ED coating

During hanging process shopfloor workers hang the raw material for ED coating line or ED-coated parts for powder line according to the instruction that shows the method of hanging, equipment, amount of details and additional information.

Hanging methods divide into:

- hanging for light and simple parts;
- hanging for light and complex parts;
- hanging for heavy and simple parts;
- hanging for heavy and complex parts.

Figures 3.6-3.9 show the examples of hanging methods for the parts.



Figure 3.6: Example of heavy parts hanging method for powder line



Figure 3.7: Example of heavy parts hanging method for the ED coating line



Figure 3.8: Example of light parts hanging method for the powder line

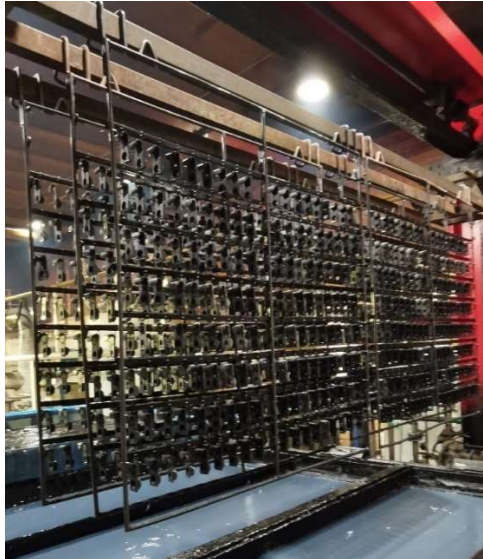


Figure 3.9: Example of light parts hanging method for the ED coating line

Masking process describes as a covering process for holes, axles and flat surfaces to protect them from unnecessary surface treatment due to customer's need, standard. Also, if thread of the nut, screw or bolt is already coated, there is also a need to mask them due to needless additional thickness that makes treads unusable for assembly. [27]

There are two main types of masking methods:

- masking with rubber caps or plugs;
- masking with heat resistant tape;
- masking with special caps or plugs that are only for exact article.

Figures 3.10-3.12 show the types of masks that are in use.



Figure 3.10: Cap shaped mask for screws and bolts



Figure 3.11: Plug shaped mask for threaded holes or nuts



Figure 3.12: Special type of mask for treaded holes, tubes or nuts

3.1.2 ED and powder coating processes

ED or electrodeposition coating is surface treatment process that uses electrical current to deposit paint on the surface to protect parts from corrosion. ED coating includes 4 main steps: pretreatment, electrocoating, post rinse and curing. [28]

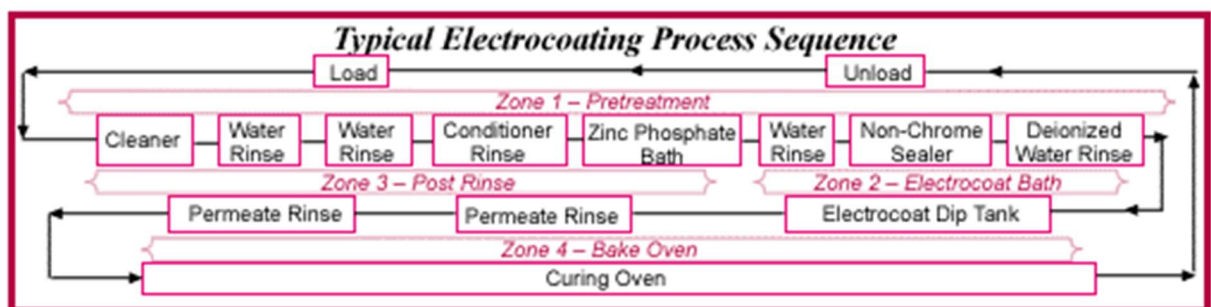


Figure 3.13: Process scheme of ED coating [28]

During pre-treatment metal parts gets cleaned from dirt, metal particles and oil in neutral pickling and alkali degreaser baths. After that parts move through the rinsing baths to be ready for activation for ZnPh coating. Activation stage promotes the

formation of dense, fine crystalline zinc phosphate coatings, especially on surfaces that have been alkali degraded. ZnPh stage improves the protection of the metal surface against corrosion forming a layer of zinc crystals, it also creates high adhesion to the subsequent coatings. It is suitable for use on steel or galvanized steel. This stage is applied by dip for a full coverage of the parts. [29], [30]

After that parts go through rinse bath with town water to reduce the carry-over of the ZnPh solution to another bath to reduce the stage contamination. Activation stage is a pre-treatment stage after ZnPh conversion coating. This stage enhances corrosion protection and contributes to an excellent adhesive substrate for the paint step by filling the gaps between the crystals to uniform the zinc layer. The last stage of pretreatment is a rinse with dionized water to prevent the contamination of the ED bath. [29], [30]

ED coating process assures the protection of the metal surface against corrosion. It applies the paint layer by electrodeposition, where the paint particles are given negative electrical charge allowing them to deposit on substrates of the opposite (positive) charge when influenced by a direct current. The paint layer has also chemical resistance and allows certain flexibility. The ultrafiltration system increases the efficiency while the anolyte system minimizes the waste. This stage is applied by dip for a full coverage of the parts. [29], [30]

During the post rinse stage, the ultra-filtration system provides a rinse solution that will remove drag out painted material that is circling to the ware exiting the electrocoat bath. Drag out is then returned to the paint bath enabling high paint usage. [29], [30]

The curing oven purpose is to bake the e-coat layer. The baking process requires certain time and temperature so that molecules are chemically combined forming a single uniform hard and solvent resistant layer. This process is called crosslinking. Volatile materials are extracted through the exhaust pipe. The stage has direct gas heating. Temperature sensor controls the gas burner and with air circulation desired temperature is maintained. The curing temperature is between 160 - 200 C° and whole curing process lasts 52 minutes. [30]



Figure 3.14: AQ Lasertool Viimsi ED coating line

Powder spraying process is the application of a top layer on ZnPh or e-coated surfaces. It is applied electrostatically, where the powder particles are charged positively and are sprayed towards the grounded object by compressed air spraying. The powder paint gives additional corrosion resistance to primer coated parts. It gives the final mechanical properties and cosmetic appearance. Powder paint is dry and solvent free. It allows to build a thicker and stronger layer than with common wet paints. [33]



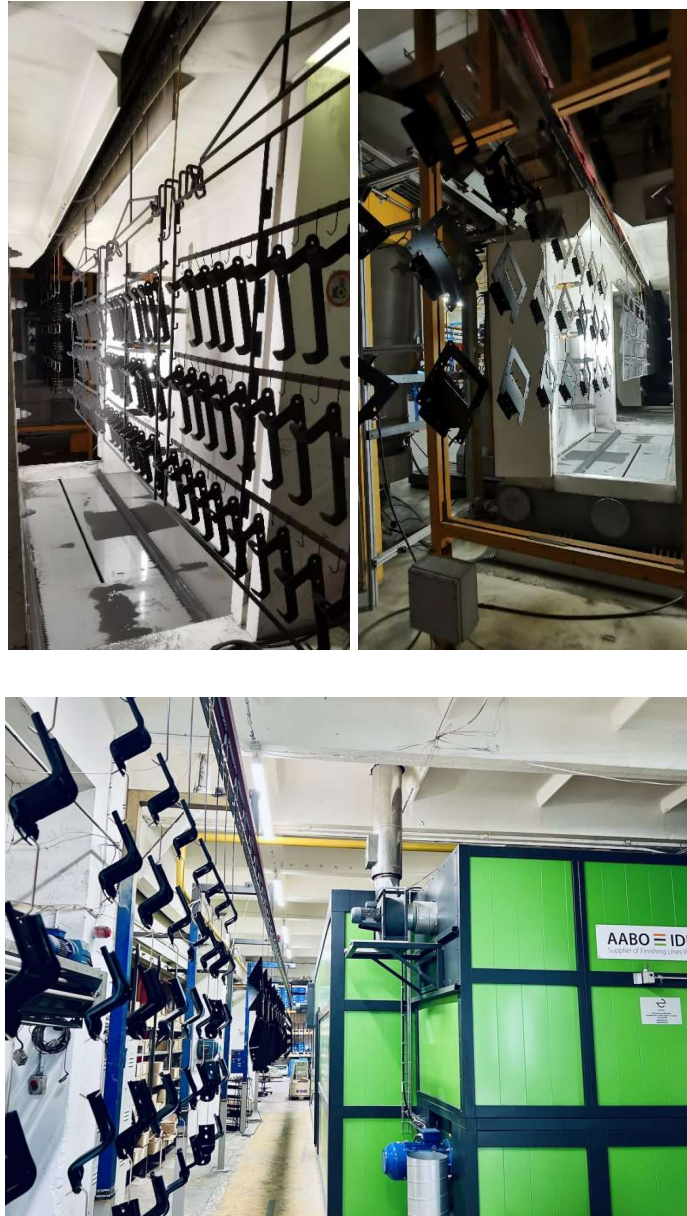


Figure 3.15: AQ Lasertool Viimsi powder line

The powder curing oven purpose is to bake the powder layer. The baking process requires certain time and temperature so that molecules are chemically combined forming a single uniform hard layer resistant to most solvents. This process is called crosslinking. The stage has direct gas heating. Temperature sensor controls the gas burner, and with air circulation, desired temperature is maintained. [31]



Figure 3.16: AQ Lasertool Viimsi curing oven [32]

3.1.3 Assembly and packing processes

The post-production processes start after powder coated surface quality inspection, which takes place on the powder line after curing process. Assembly is not so common process, because it depends on the production and time costs and customer needs. If production capacity, equipment and assembly difficulty answers the standards, so it has more possibility that part is going to be fully prepared for usage. Figure 3.17 shows the example of assembling process of the complex part.





Figure 3.17: Assembly process for the Scania battery box

The last process of the whole production is a packing. Packing goes according to customer needs and their packing instructions and packing material. Customer's packing instruction includes article number, amount of packaging material, number of parts per layer or box, total amount of parts, issue date and additional information. If there is a problem related to the packing method, so AQ Lasertool informs the customer and suggest their solution that provides the protection during transportation, reasonable quantity of parts and simplicity of packaging method for operators. After the packing part is ready to go to the customer plant for the final assembly.

Figure 3.18 shows:

- the example of packing for Scania;
- the example of packing for Volvo;
- the example of packing for others clients.



Figure 3.18: Examples of packing solutions according to the customers and their needs

3.2 Bottlenecks

Bottleneck is occasion or place during production processes, where the time, volume or safety indicators show lower numbers than usual ones, causing delivery delays, financial fines and safety risks. [35]

The main bottlenecks that can occur during surface treatment, related to: [35], [36]

- quality issues;
- lack of equipment and/or materials;
- lack of human resources;
- transportation delays;
- communication issues;
- unforeseeable circumstances (war conflict, economic crisis, pandemic etc.).

Bottlenecks mostly related to the surface treatment defects that come during the ED and powder coating: large or insufficient thickness of the top coat, paint cracks, drips, marks, colour deviation, orange peel and particles under the top coat. Common ones are the issues, that caused by:

- dirty masks;
- human error;
- insufficient information;
- unprepared raw material from the supplier;
- wrong speed on the powder line;
- wrong colour of the detail;
- incorrect hanging during ED coating.

Figures 3.19 – 3.25 show the examples of defects that cause bottlenecks.



Figure 3.19: Defect caused by dirty mask



Figure 3.20: Human error during the packing process

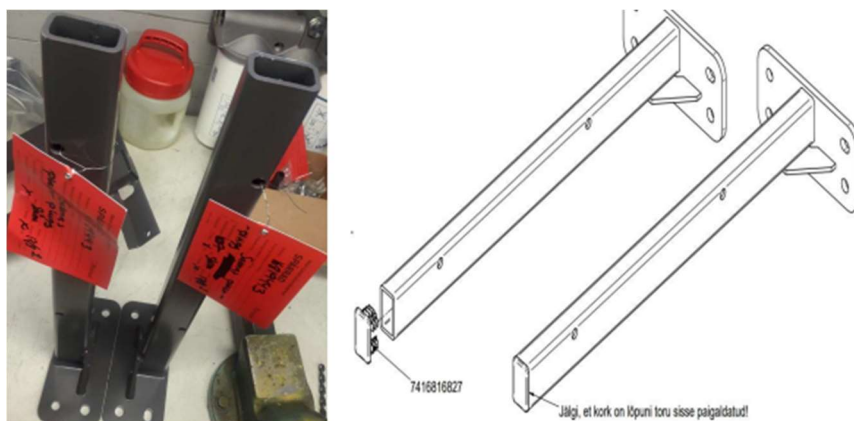


Figure 3.21: Insufficient information about the assembly process

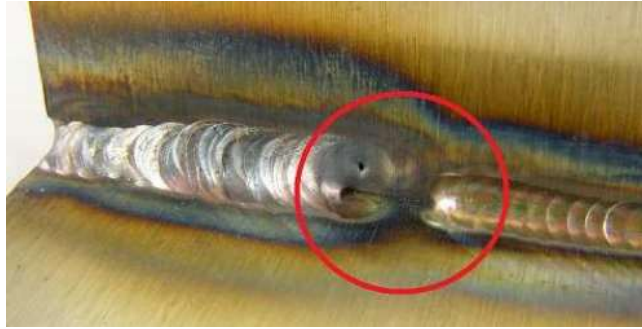


Figure 3.22: Poor quality of the raw material due to pore inside the weld



Figure 3.23: Large number of thickness due to wrong speed on the powder line



Figure 3.24: Wrong type of colour was used for the powder coating



Figure 3.25: Inadequate distance between parts on the ED coating line

Another bottlenecks, like lack of equipment or materials mostly related to transportation delays or warehouse shortages on the warehouses of the maintenance company or material supplier. Lack of human resources usually related to the irrelevant sales needs from the customer. In addition, the last 2 years have the full of unforeseeable circumstances, like Covid-19 pandemic, war in Ukraine and economic crisis caused by their combination.

The consequences than can occur, if company will not be going to start solving the causes of bottlenecks, mostly related to finances and reputation of the main customers. Mainly, company will receive less funds from clients and the AQ Group itself and possible reputation losses cause the closing it or selling the company to another concern, that bring more downtimes due to process of adjusting.

3.3 Key Performance Indicators

KPI or Key Performance Indicator is an indicator or number of indicators that show the efficiency of performance over some period for the specific type of action. Table 3.1 shows KPI that are in use in AQ Lasertool OÜ. [36]

Table 3.1: Main Key Performance Indicators of AQ Lasertool OÜ

	Key Performance Indicator	Description
1.	Production capacity	Shows the percentage of finished and sent order according to the production plan.
2.	Delivery Performance	Shows the percentage of sent products to the customers according to the sales plan.
3.	Number of reclamations	Shows the amount of quality or delivery claims from main customers

4. CASE STUDY OF SURFACE TREATMENT PROCESSES

Use case of the master thesis is going to show more detailed information how lean tools were implemented into surface treatment processes. The use case consists of three main topics: VSM analysis to mark areas and processes that have major influence on the production, lean solutions implementation with examples (Poka-Yoke), KPI analysis before and after the implementation with calculations.

4.1 VSM analysis

VSM analysis helps to identify valued processes and wastes that can affect the value of product. Analysis divides into 2 main parts: Current State Map and Future State Map. Current State Map shows the current flow of entire production, its planning and support. Future State Map shows the upgraded flow of entire production, where the wastes are minimized or eliminated and/or more value-added decisions implemented.

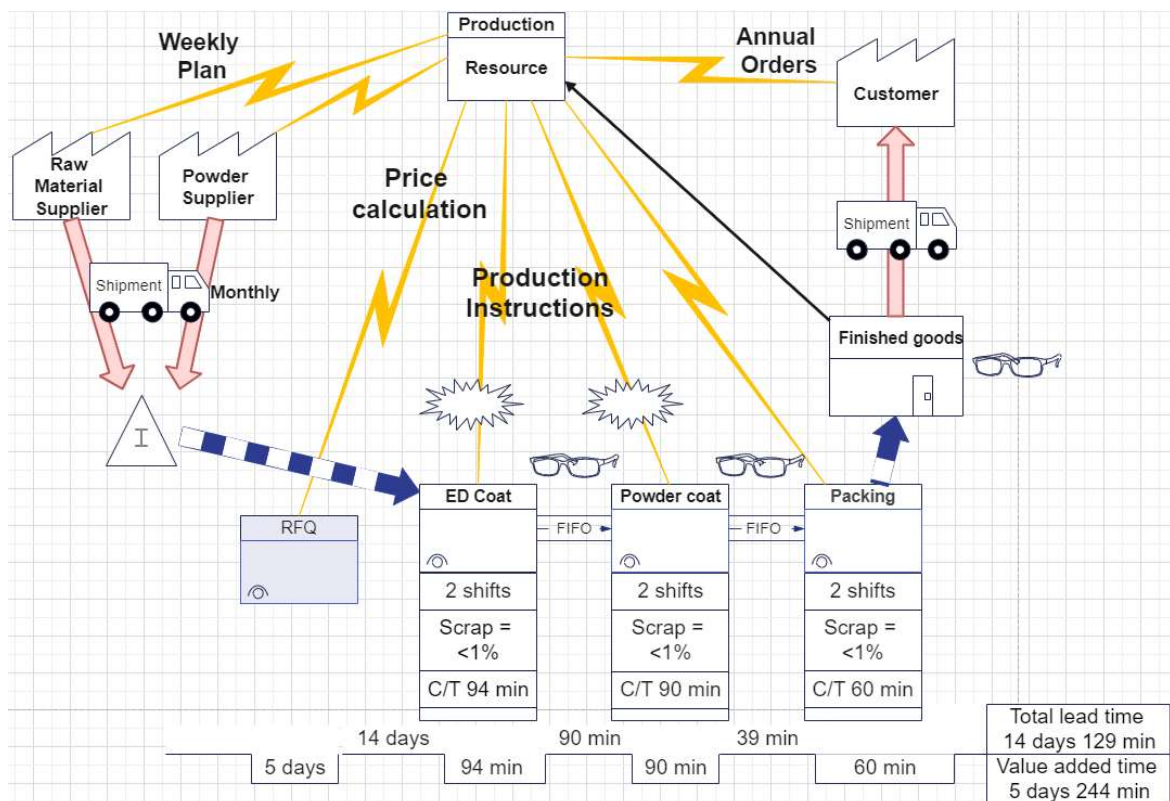


Figure 4.1: Current State Map of the production at AQ Lasertool Viimsi plant

According to the Current State Map (Figure 4.1), there are Kanban posts only on ED and powder coating processes. It means that main attention is gathering only for these two processes. Also, digitalized instructions coming only to the main surface treatment

processes. All in all, it means that packing and pre-production processes like RFQ are missing the Kanban posts that can have crucial negative effects in case of problem. Also final processes like packing and assembly must also receive information digitally to increase the information flow and its quality.

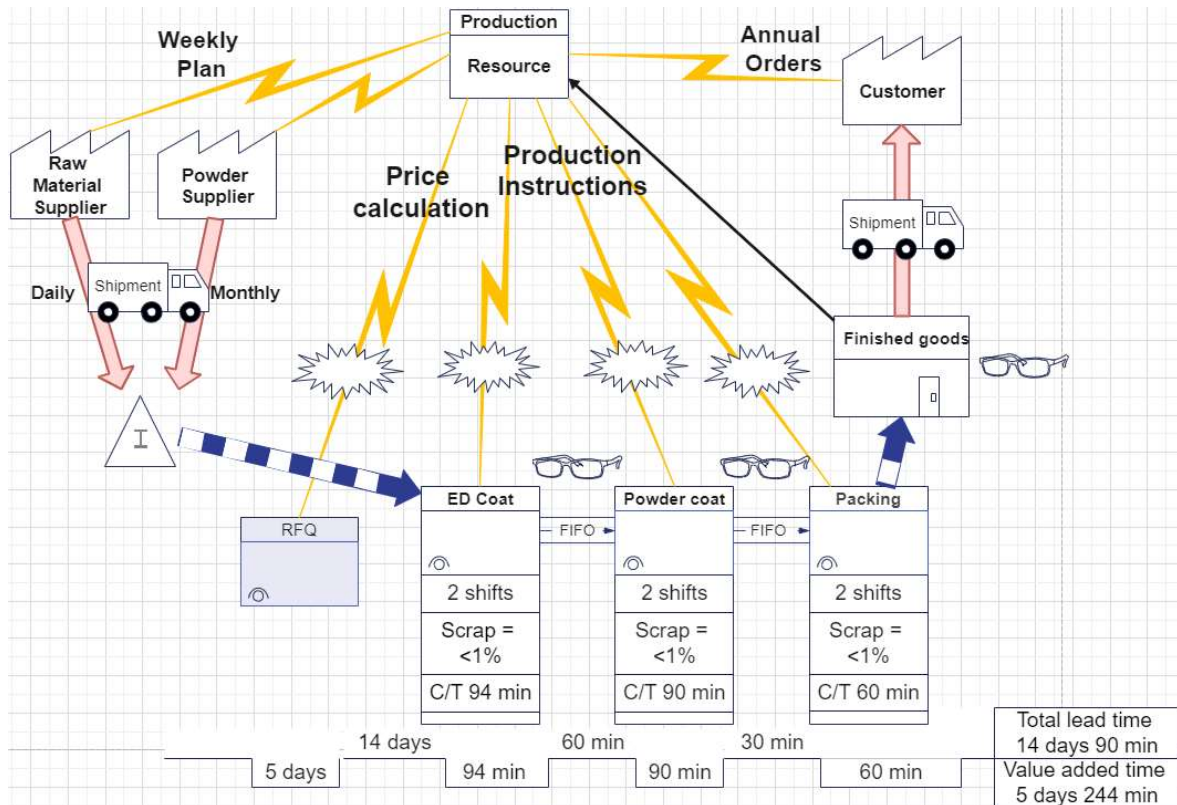


Figure 4.2: Future State Map of the production at AQ Lasertool Viimsi plant

Future State Map (Figure 4.2) shows the improvements that need to be integrated into production stream to increase the value or manage to decrease or eliminate the bottlenecks in the future. Kanban posts are added to pre-production (RFQ) and final (packing and assembly) processes. Digital instructions are also implemented for final processes.

Kanban post for the RFQ helps with evading future risks like parts that Viimsi plant cannot afford to paint due to measuring, hanging, coating problems that cause defects that staff cannot eliminate, or elimination require a huge amount of production costs. The RFQ must include technical documentation (drawings, 3D models and PVR), annual amount, batch quantity, type of colour, BOM list (threaded parts) and special requirements.

The next step after VSM analysis is to mark down more common bottlenecks and solutions that should be implemented for them (Table 4.1).

Table 4.1 Main processes, causes and solutions implementation table

Process	Cause of the bottleneck	Solution
RFQ	insufficient information communication delays	More detailed package of technical documentation (3D models, drawings, PVR, annual and batch quantities etc.)
Quality control	insufficient information flow	error catalogue
Hanging	insufficient information flow unsuitable equipment or lack of it human error	proper instructions suitable equipment
Masking	insufficient information flow unsuitable equipment or lack of it human error	proper instructions suitable equipment
ED coating	human error insufficient information flow defects	proper instructions plan monitoring
Powder coating	human error insufficient information flow defects	proper instructions plan monitoring
Packing	lack of materials communication delays insufficient information	proper instructions

4.2 Lean solutions and their implementation

The result after VSM analysis brought to the attention that Future State Map shows the decreasing factors like scrap percentage and total lead time, it comes due to implementation of the new hanging equipment for ED and powder equipment that were tested and implemented exactly for these kinds of processes.



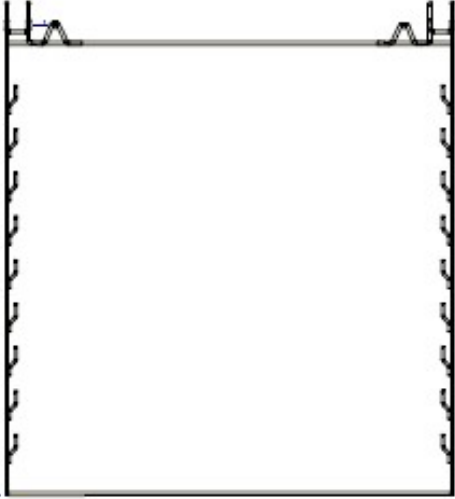
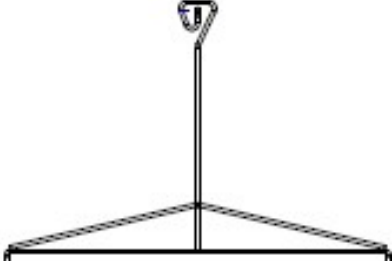
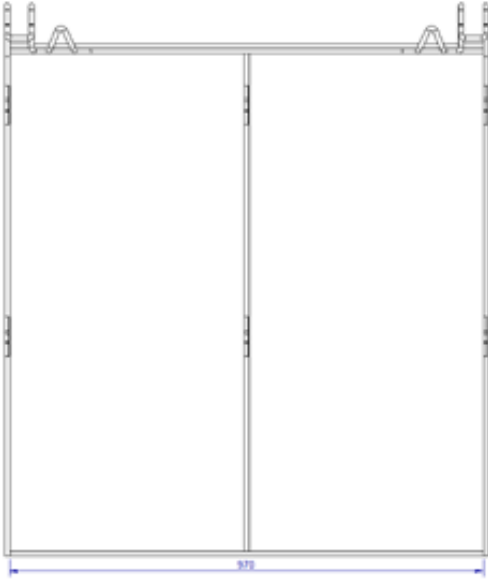
Figure 4.3: Old frame for ED and powder coating

Old frame made of sheet metal parts that have been welded together. The roots of the problem come from their maintenance. If coating thickness on the frame is huge enough it blocks the contact with electrical impulse and parts are going to be uncoated. Operators need to use cleaning oven to get rid of the coating material, but the entire frame must be placed inside.

Also, jigs are not interchangeable, and the only way is to cut them down and weld the new ones, which makes this process more complicated, inefficient. That is why there is a crucial need of hanging equipment modification.

The list (Table 4.2, 4.3) consists of new frames, jigs for light and heavy parts. Also, it includes the additional hanging equipment for the frames.

Table 4.2: List of new hanging equipment for surface treatment processes

Article	Visual example
<p>HCF 1000 2U</p>	
<p>HCF 2U AQ</p>	
<p>HCF 1000 2U Middle</p>	

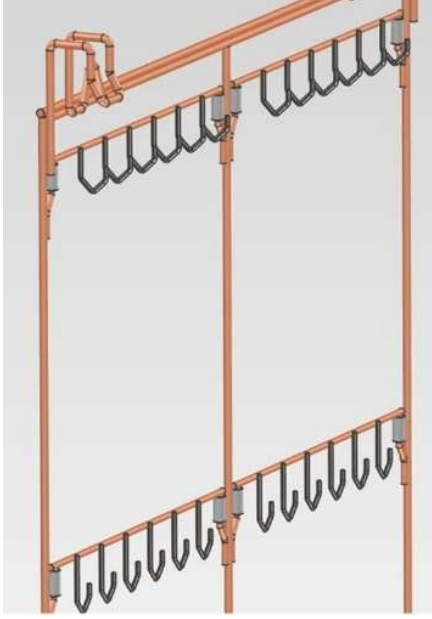
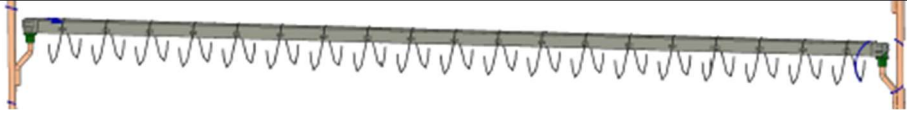



<p>HCF V2 (frame)</p> <p>4x4 V2 (upper jig)</p> <p>4x4 V3 (lower jig)</p>	
--	--

Table 4.3: List of jigs for the HCF 1000 2U and HCF 1000 2U Middle



Article	Visual example
F38/90°	
F20/90°	
F38X	
F20X	

The main advantage of these types of frames and jigs that they are mirrored, so each side is the same, so there is no wrong side for the parts during surface treatment processes like ED or powder coating. Entire list of equipment works with the way of Poka-Yoke principle. It means that there is only one right method and operator has no possibility of making a mistake that can cause problems in future. The jigs also have

connection ports on the end of both sides to make sure that electrical impulse will go without any issue. To make sure that these frames and jigs are working, there are some tests (Table 4.3) that compare the number of parts per one frame.

Table 4.3: Comparison of the articles with implemented equipment

Product Article	Amount (Old frame)	Amount (New frame)	Visual example
VL21840257	50 pcs	190 pcs	
VL22065195	30 pcs	54 pcs	

VL21897178	50 pcs	100 pcs	
BR2140999	18 pcs	18 pcs	

To continue the implementation, the base of production instructions is also analysed and changed. Old base was made via Microsoft Excel, which means that there was no freedom of designing for the engineer to analyse technical documentation (3D models and drawings) and create or modify the instruction according to the specifications. The reason also that for 3D models and drawings AQ Lasertool engineers use Solid Edge CAD program. The implementation consists of the new base for instructions that via Solid Edge.

The new base of instruction divided into three parts instead of one in the old version. The reason that these three parts related to the main processes (ED, powder, packing) and have Kanban posts, so better focused instruction is the key to pay attention on the process.

Table 4.4: Old and updated versions of instruction bases

	Type of instruction	Visual example
1.	Old base for ED and powder coating	
2.	New base for ED and powder coating	

3.	New base for packing	

LASERTOOL		E-Tool		Page: 1		Number of the document: A3	
E-Tool article / barcode:		Issued by:		Date:		Next workstation:	
		Approved:					
		Packaging:		Covering for the tool:		Covering for the tool:	
Title:							
Workstation	Surface treatment	Powder	Material thickness	Coating thickness	Amount per hook	Amount per frame	Amount per 1 m line
	Masking	Amount per frame	Type of frame	Amount per 1 m	Type of jig	Amount per frame	Program for powder guns
1	G40 M6X30	1		1			
2	H0L G6	2		2			
3		3		3			
4		4		4			
5		5		5			
ADDITIONAL INFO:							
VISUAL INFO:							

Figure 4.4: Main aspects of the new base for ED and powder coating

Old base of instruction includes all information for ED and powder coating that divided into small groups that difficult to modify if there is new revision of the part or modification for the hanging process, also the size of text tends to be difficult to change if there are some new requirements for the coating processes. In addition, the old base has a disadvantage of information that not needed for the operators or makes them difficult to understand.

The upper part of new base consists of title, revision information and article number. Upper table consists of workstation, type of surface treatment, powder name/code (for powder coating), material thickness and amounts per jig, frame, bar, or 1 m. The lower table consists of BOM list, where written down all masks, frames, jigs, and their amount, also the program for powder guns (powder coating). The additional information is for special requirements or doubled information. Visual information is for pictures of hanging methods, masking, and another crucial requirement from the customer.

The base for packing instruction mainly focuses on the visual information, mostly detailed instructions that includes pictures of the layers of finished goods that are packed and ready for delivery and packing material that needs to be used. Old base has been made with Microsoft Word program and tends difficult to use due to number of used programs for the preparation of production processes.

Finally, solution for information flow that consists of monitors that all needed up-to-date information for the operators, specialists, and the others.

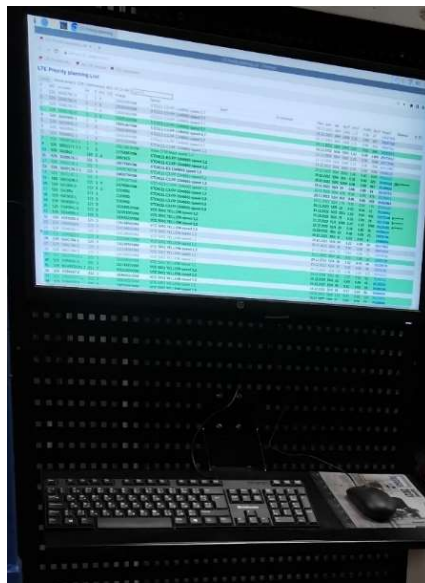


Figure 4.4: Plan monitoring and report for ED and powder coating processes



Figure 4.5: Monitoring camera to see the exact parts that will come after ED process



Figure 4.6: Powder coating monitoring with all needed information for the painters



Figure 4.7: Monitor for packing instructions and status reporting

All needed information comes from the company servers with all necessary files that could be uploaded by engineer, production planner or plant manager.

4.3 Calculation and KPI analysis

The next step after the implementation is the calculation and Key Performance Indicators analysis. Calculation consists of unit time comparison and KPI analysis consists of comparison of productivity and number of reclamations.

Tables 4.5 and 4.6 show the comparison of unit time for tested parts during ED and powder coating processes. Unit time calculation goes with using special formula for ED (4.1) and powder coating (4.2).

Formula for ED coating:

$$t_{ED} = \frac{8,66}{N_{BAR}} \quad (4.1)$$

where

t_{ED} – unit time, min

8,66 – constant for ED process

N_{bar} – amount of parts per bar, pcs

Formula for powder coating:

$$t_{pow} = \frac{1}{N \times V} \quad (4.2)$$

where

t_{pow} – unit time, min

1 – constant for powder coating process

N – amount of parts per 1m, pcs

V – line speed, m/min

Table 4.5: Unit time comparison for ED

Article	Unit time (old method)	Unit time (new method)
VL21840257	0,0515 min	0,0076 min
VL22065195	0,0721 min	0,0267 min
VL21897178	0,0288 min	0,0144 min
BR2140999	0,0802 min	0,0802 min

Table 4.6: Unit time comparison for powder coating

Article	Unit time (old method)	Unit time (new method)
VL21840257	0,0297 min	0,0044 min
VL22065195	0,1250 min	0,0154 min

VL21897178	0,0227 min	0,0166 min
BR2140999	0,0643 min	0,0556 min

As a result of comparison, there is a visible positive change of unit time, it means that there needs less time for one part to be coated with ED and powder.

Tables 4.7 and 4.8 show comparison of productivity and number of reclamations. [37]

Table 4.7: Productivity comparison [37]

	Jan	Feb	Mar	Apr	May	Jun	Jul	Aug	Sep	Oct	Nov	Dec wk 51
Target	80%+ per month											
2021	83%+ per month (average)											
2022, %	81	80	75	83	73	75	69	78	80	88	97	115

Table 4.8: Comparison of reclamations [37]

	Jan	Feb	Mar	Apr	May	Jun	Jul	Aug	Sep	Oct	Nov	Dec wk 51
Target	Max 3 claims per month											
2021	1,5 claims per month (average)											
2022, pcs	2	1	5	0	1	2	0	2	8	1	1	1

As a result of KPI analysis, the numbers are slightly decreased in 2022 comparing with 2021. But the average productivity of 2022 is 81,96% and average number of claims is 1,9 that means indicators still meet the targets. Also need to take in consideration that more unforeseeable circumstances with severe effects came during 2022.

SUMMARY

The main idea of the thesis is the analysis of implementation results of lean principles to the production processes and to show, what is lean and why does it need in our days. Main objectives consist main bottlenecks defining, finding of lean solutions, surface treatment processes analysis and lean tools implementation solutions.

During the VSM analysis of the surface treatment processes found out that the main bottlenecks relate to the RFQ, ED, powder coating and packing processes. The cause of the bottlenecks mostly insufficient information and unsuitable equipment, which means that there is a need of better information flow and suitable equipment.

The implementation phase consists of new hanging equipment and modified base for work instructions. New frames and jigs made with principles of Poka-yoke tool, which means that operator cannot put them wrong. New base for instructions provide faster modification for the engineers and more understandable desing for the operators. The monitoring possibilities were also improved to increase the speed and quality of the information flow. Also, new RFQ process development that improves the quality and quantity of information that leads to better calculation and possible defects evasion or their minimization.

Calculations of tested articles show that the unit time for each part has a visible improvement, which means it needs less time to cover the part with ED and powder. Also KPI analysis show that the main indicators already meet the targets after solutions implementation. But there is a need of consideration that some months in 2022 have lower KPIs values than the annual average of 2021 due to unforeseeable circumstances like war in Ukraine, increased gas, electricity and materials prices due to the inflation. However, the process improvement activities and solutions are developed and tested, so by continious implementation of these solutions, better results will be highly expected in the upcoming years.

In conclusion, to keep solutions working there is a need of better information flow between the departments and production plants to sustain a smother and predictable production flow, where customers would receive more value from the products and suppliers would receive more value from the better quality, lower costs and increased reputation.

KOKKUVÕTE

Käesolev magistritöö tutvustab pinnakatmise protsesside optimeerimisega AQ Lasertool OÜ Viimsi tehase näitel. Töö eesmärk on tootmisprobleemide leidmine ning nende vastu sobivate lahenduste analüüs, valimine ja juurutamine. Tööl seletatakse tootmise optimeerimise printsiibid ja kuidas neid praktikas kasutada, pinnakatmise protsessid, nende eripärad ja probleemid, mis võivad ilmuda nende kasutuse jooksul. Tootmisanalüüs, mis aitab probleemi defineerida ning parimate lahenduste valiku lihtsustada.

VSM analüüs näidanud, et pinnakatmise põhiprobleemid tulevad hinnapakkumise, ED ja pulbriga pinnakatmise ning pakkimise protsessidest, mille põhjusteks on halb infovool ja sobimatu varustus ja vahendid.

Juurutamise faas koosneb uutest riputusvahenditest ja uutest vormidest tootmisjuhendite jaoks. Uued raamid ja konksulatid valmistatud Poka-yoke printsiipi kasutades, mis tähendab, et operaator ei saa neid valesti kinnitada ja riputada. Uued vormid kiirendavad juhendite modifitseerimist inseneridele ja selgitavad operaatorile paremini tegevusi ja materjale, mida vaja kasutada pinnakatmise jaoks. Jälgimisvõimalused optimeerimisele ka jõudnud, mis tähendab, et infovool saab kiiremini ja parema kvaliteediga tehase sees liikuda. Lisaks ka hinnapakkumise protsessi arendamine teeb saabuvat infot detailsemalt, mis parandab detailide kalkulatsiooni ning võimalike defektide vältimist või mõju vähendamist.

Katsetud artiklite kalkulatsioonid näitavad, et tükki aeg ühe detaili jaoks on nähtavalt parenenud, mis tähendab, et nüüd vaja vähem aega ühe detaili pinnakatmise jaoks. Lisaks ka põhikasutegurite analüüs näitab, et juurutatud lahendused juba vastavad planeeritud eesmärkidele. Aga siia ka tuleb võtta, et aastal 2022 oli rohkem asjaolusid, mida ei saa ei mõjutada, ega ära hoida: sõda Ukrainas, gaasi-, materjalide ja elektri hinnad, inflatsioon. Seetõttu aasta 2022 mõned kuud on halvemad võrreldes samadega, aga aastal 2021. Aga protsessi arendamistegevused ja -lahendused arendatud ja tootmises katsetatud ehk lähimatel aastatel nende pidev juurutamine peab suure tõenäosusega paremaid näitjaid tooma.

Kokkuvõtteks, lahenduste töö säilimiseks tuleb infovoolu arendada üksuste ja tehaste vahel, et paremat väärtust nii tootjale kui ka lõppkliendile saavutada.

LIST OF REFERENCES

- [1] "AQ Lasertool OÜ," [Online]. Available: <https://www.aqgroup.com/en/lasertool/aq-lasertool-ou> [Accessed 03.10.2022]
- [2] "AQ Group history," [Online]. Available: <https://www.aqgroup.com/en/aq-group/about-aq-group> [Accessed 03.10.2022]
- [3] "Core Values," [Online]. Available: <https://www.aqgroup.com/en/core-values> [Accessed 03.10.2022]
- [4] "Multi-year financial overview," [Online]. Available: <https://www.aqgroup.com/en/investor/financial-information/multi-year-overview> [Accessed 04.10.2022]
- [5] "Volvo Group," [Online]. Available: <https://www.volvogroup.com/en/news-and-media/news/2019/feb/our-unique-position-in-electric-mobility.html> [Accessed 04.10.2022]
- [6] "Scania main page," [Online]. Available: <https://www.scania.com/> [Accessed 05.10.2022]
- [7] "MAN main page," [Online]. Available: <https://www.man.eu/de/en/homepage.html> [Accessed 05.10.2022]
- [8] P. Dennis, *Lean Production Simplified: A Plain Language Guide to the World's Most Powerful Production System*, Boca Raton: CRC Press, 2015.
- [9] "Lean Principles," [Online]. Available: <https://tataandhoward.com/tag/4-ps-of-lean/> [Accessed 16.11.2022]
- [10] J. Likker, *The Toyota Way: 14 Management Principles from the World's Best Manufacturer*, New York: McGraw Hill, 2004.
- [11] "Kaizen definition," [Online]. Available: <https://leansmarts.com/lean-101/kaizen/> [Accessed 18.11.2022]
- [12] "Kaizen approach," [Online]. Available: <https://www.bobstanke.com/kaizen> [Accessed 18.11.2022]
- [13] "7 Wastes," [Online]. Available: <https://kanbanize.com/lean-management/value-waste/7-wastes-of-lean> [Accessed 18.11.2022]
- [14] J. P. Womack, D. T. Jones, D. Roos, *The Machine that Changed the World*, New York: Simon and Schuster, 2007.
- [15] "5S," [Online]. Available: <https://www.5stoday.com/what-is-5s/> [Accessed 18.11.2022]
- [16] J. Ries, *Lean Enterprise*, New York, 2018.
- [17] J. Paulo Davim, *Progress in Lean Manufacturing*, Berlin: Springer, 2018.
- [18] J. Ries, *Lean, Six Sigma*, New York, 2018.

- [19] M. Rother, *Toyota Kata: Managing People for Improvement, Adaptiveness and Superior Results*, New York: McGraw Hill, 2009.
- [20] M. Réquillard, *How to Build a Value Stream Mapping*, 2020.
- [21] "Value Stream Mapping," [Online]. Available: <https://www.nist.gov/mep/value-stream-mapping> [Accessed 03.12.2022]
- [22] "VSM creation," [Online]. Available: <https://asq.org/quality-resources/lean/value-stream-mapping> [Accessed 03.12.2022]
- [23] "VSM Symbols," [Online]. Available: <https://www.edrawmax.com/article/value-stream-mapping-symbols.html> [Accessed 03.12.2022]
- [24] "Error proofing," [Online]. Available: <https://asq.org/quality-resources/mistake-proofing> [Accessed 04.12.2022]
- [25] S. Savant, *Poka Yoke Error Proofing*, 2018.
- [26] AQ Lasertool OÜ, "Gouldsmith demagnetizer user guide," Internal document, 2022.
- [27] AQ Lasertool OÜ, "Hanging and masking user guide," Internal document, 2022.
- [28] "E-coat process specifics," [Online]. Available: <https://www.ppgcoatingservices.com/services/electrocoating/e-coat-process-specifics> [Accessed 07.11.2022]
- [29] M. Brüggemann, A. Rach, *Electrocoats: Formulation and Technology*, Hanover: Vincentz Network, 2020.
- [30] AQ Lasertool OÜ, "ED process description," Internal document, 2022.
- [31] AQ Lasertool OÜ, "Curing oven manual," Internal document, 2022.
- [32] "Ready projects: AQ Lasertool Viimsi," [Online]. Available: <https://elister.ee/projektid/aq-lasertooli-viimsi-tehase-pulbervarviliin-labis-korraliku-uuenduse/> [Accessed 10.11.2022]
- [33] AQ Lasertool OÜ, "Stage manual: Powder spraying," Internal document, 2022.
- [34] AQ, Lasertool OÜ, "Stage manual: Powder curing oven," Internal document, 2022.
- [35] K. Karström, J. Noreng, J. Gidlund, L. Lundström, *Surface Treatment Industry in the Nordic Countries: Overview and BAT Examples*, Copenhagen: Nordisk Ministerråd, 2021.
- [36] R. Usubamatov, *Productivity Theory for Industrial Engineering*, Boca Raton: CRC Press, 2018.
- [37] AQ Lasertool OÜ, "Viimsi KPI," Internal document, 2022.


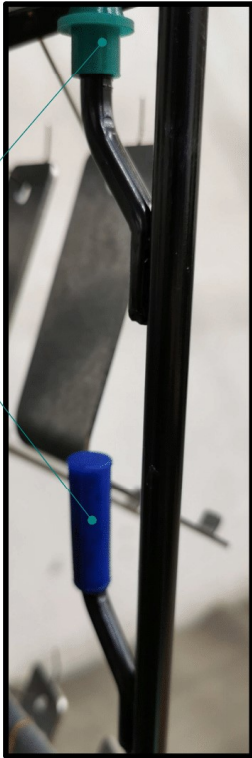
APPENDICES

Appendix 1: Old base of instruction

TÖÖJUHEND												
Detaili nr:					Operatsioon:							
Klient:					Detaili kaal:							
Koostatud:					Väljaande kp:			Versioon nr.: 1				
Tootmise tööjuhend / Производственная инструкция												
Spetsifikatsioon / Спецификация					Detaili perekond / Тип детали					Perekond 1		
Värvi tüüp / Тип Краски					Prog. [Liini kiirus]/Прог. [скорость]							
Raam/konks 1		H400		Konks 1 (tk)		Konksu tüüp 2		Konks 2 (tk)				
Detailide kogus / Кол-во деталей					Pulber: konksu vahe / Расст. межд. крючками					2		
Värvi paksus/Толщина краски (µm)					70-200 [110 max]*		Järgm. OP/След операция		FG			
Asetus raamil [konksul] / Располож. на раме [крюке]					Riputamise ava / Отверстие для подвески							
PILT PUUDUB / ФОТО ОТСУТСТВУЕТ					PILT PUUDUB / ФОТО ОТСУТСТВУЕТ							
Maskeerimise meetod / Метод маскировки					Kriitiline informatsioon / Критическая информация							
Maski tüüp 1 / Тип маск. 1		WE08		Kogus		NB1!		Keermed peavad olema värvist puhtad !				
Maski tüüp 2 / Тип маск. 2				Kogus		NB2!		rezyba dolzhi byt' chistyh ot kraski !				
Maski tüüp 3 / Тип маск. 3				Kogus								
Maski eemaldus/ Извлеч. маск.		Pärast ahju / После печи										
Maskeerimise kohad / Область маскировки					Kriitilised kohad / Критические поверхности							
PILT PUUDUB / ФОТО ОТСУТСТВУЕТ					PILT PUUDUB / ФОТО ОТСУТСТВУЕТ							
Pakkimise juhend / Упаковочная инструкция												
<input type="checkbox"/> Detailid pakki sama moodi kuidas need tulid kliendilt (Free packing) / Детали упаковывать так же как получены от клиента												
<input checked="" type="checkbox"/> Järgi tootespeetifilist pakkejuhendit / Специальная упаков. инструкция												
Inspection Results / Результаты контроля												
Kuupäev / Дата	Kellaeg / Время	Pinnakatte paksus µm / Толщина краски µm					Kraaretest (OK/NOK?)	Väruaalne / Визуальн. (OK/NOK?)	Detaili nr. kontroll / Проверка Нр. детали	Koguse kontroll / Проверка кол-ва	Pakkimise kontroll / Проверка упаковки	Allkiri / Подпись
		1	2	3	4	5						
Kommentaariid:												


* Värvi paksus sulgudes "[]" kehtib kontakt pindadele (avad, riiud, jne.) / Толщина краски в указанной в скобках "[]" Мента для контактных зон (отверстия, щели, зазоры и т.д.)

Appendix 2: ED coating instruction with the new base

aa LASERTOOL		ERP article / Monitor code: 21840257VIIM		Rev: 1	Ver: 1	Page: 1/1	Number of the document: SDPVPR10W102122020_VL21840257		A3
ERP article / barcode:				Issued by: Jan Golönski		Date: 02.12.2020		Next workstation: 526	
				Approved: Gert Viira					
Placement: C:\Users\viigo\Desktop\Tootjuhendid\21840257viim\21840257VIIM.dft									
Title: VL21840257 E-COAT INSTRUCTION									
Workstation	Surface treatment	Material thickness		Coating thickness		Amount per jig	Amount per frame	Amount per bar	
525	E-coat	2 mm		20 (+5) µm		38	190	1140	
	Masking	Amount per frame		Amount per frame	Type of frame	Amount per bar		Type of jig	Amount per frame
1	GAQ M6X30	8	6		5601KH18146228	6	1	5601KH18145743	5
2	HQL G6	10	7				2		
3			8				3		
4			9				4		
5			10				5		
ADDITIONAL INFO:									
1) Maskings per frame: GAQ M6x30 (8 pcs), HQL G6 (10 pcs).									
2) 38 pieces per jig, 5 jigs per frame.									
									
Distr. list: E-coat									

This document and its contents are the property of AQ Lasertool OÜ and must not be copied, reproduced or disclosed to any third party without prior written permission. Contravention will be prosecuted.
All rights reserved. Copyright (C) AQ Lasertool OÜ 2020 <http://aaq.se/en/lasertool> The base of instruction developed by: Mr. Jan Golönski & Mr. Annes Sutt

Appendix 3: Powder coating instruction with the new base

LASERTOOL		ERP article: / Monitor code: 21840257VIIM		Rev: 1	Ver: 1	Page: 1/1	Number of the document: SDPVPRIOW102122020_VL21840257		A3
ERP article: / barcode:				Issued by: Jan Golõnski		Date: 02.12.2020	Next workstation: 612		
				Approved: Gert Viira					
Placement: E:\kõrvaldus\Desk\top\juhendid\21840257\viim\21840257VIIM.dft									
Title: VL21840257 POWDER INSTRUCTION									
Workstation	Surface treatment	Powder		Material thickness	Coating thickness	Amount per hook	Amount per frame	Amount per 1 m line	
526	Powder coating	VOLVO 1042 SEA WOLF BLUE		2 mm	75 - 200 µm		190	190	
Standard:									
	Masking	Amount per frame		Type of frame	Amount per 1 m		Type of jig	Amount per frame	Programm for powder guns
1	GAQ M6X30	8	1	5601KH18146228	1	1	5601KH18145743	5	5
2	HQL G6	10	2			2			
3			3			3			
4			4			4			
5			5			5			
ADDITIONAL INFO:									
1) Maskings per frame: GAQ M6x30 (8 pcs), HQL G6 (10 pcs).									
2) 38 pieces per jig, 5 jigs per frame									
3) Use TOPHANGER HCF 2U AQ 5601KH18144871									
VISUAL INFO:									
									
1. Salvesta digitaal nimel: "ERP artikkel_paintshop"									
2. Instruktsioon, millele on tehtud käsitsi info korrigeerimine, tuleb edastada INSENER-TEHNILISELE PERSONALILE (töökeskuse juht, vahetusevanem).									
Distr.list:		Powder							

Appendix 4: Packing instruction with the new base

aa LASERTOOL	ERP article / Monitor code: 21840257VIIM	Rev: 1	Ver: 1	Page: 1/1	Number of the document: 12/20/VL21840257	A3
ERP article / Barcodes:		Issued by: Jan Golönski		Kehitv alates: 02/12/2020		
		Approved: Gert Viira				
Dokumendi esmane asukoht sisevõrgus: <small>E:\Users\jgol@desk\top\Tööjuhendid\21840257\viim\21840257VIIM.d#1</small>						
Title: VL21840257 PACKING INSTRUCTION						
PACKING INFORMATION						
Workstation	Surface treatment	Standard	Method of packing	Packing barcode		
612			VLK500 - 75 pcs			
ADDITIONAL INFO: 1) 3 layers (20 pcs each) 3) Top layer (15 pcs) 2) Foam spacer under each layer						
VISUAL INFO: <div style="display: flex; justify-content: space-around; align-items: center;"> <div style="text-align: center;">  <p>1</p> <p>3</p> </div> <div style="text-align: center;">  <p>2</p> </div> </div> <p>1. Salvesta digifaili nimekuju: "ERP_artikkel_paintshop"</p>						
Distr.list:		E-coat, Powder				

GRAPHICAL MATERIAL

Graphical material 1: Viimsi plant layout

