



TALLINN UNIVERSITY OF TECHNOLOGY
SCHOOL OF ENGINEERING

Department of Electrical Power Engineering and Mechatronics

Cocktail Machine Structural Design

MASTER THESIS

MECHATRONICS PROGRAM

Student: *Nikita Shmakov*

Student code: *163858MAHM*

Supervisor: professor Mart Tamre
Assoc. Prof. Stanislav Reznikov (ITMO)

Tallinn, 2017

AUTHOR'S DECLARATION

Hereby I declare, that I have written this thesis independently.

No academic degree has been applied for based on this material.

All works, major viewpoints and data of the other authors used in this thesis have been referenced.

Thesis is completed under the supervision of professor Mart Tamre

“.....”201.....

Author:

/signature/

Thesis is in accordance with terms and requirements

“.....”201.....

Supervisor:

/signature/

Accepted for defence

“.....”201.....

Chairman of theses' defence commission:

/signature/

TTU
School of Engineering
THESIS TASK

Student: Shmakov Nikita 163858MV

Study programme, main speciality: MAHM Mechatronics

Supervisor: Professor Mart Tamre

PhD Stanislav Reznikov

Consultants: (position, name, company)

Thesis topic:

(in English) Cocktail Machine Structural Design

(in Estonian) Kokteilimasina projekteerimine

Thesis proposal

1. Introduction

Nowadays, market offers us a huge amount of different devices and gadgets, which are supposed to make our life easier and more convenient. Cocktails machines and robot bartenders are not an exception. They are designed as for placing in clubs and bars for acceleration and accuracy of drinks extradition, or for using at homes to get a fine drink without any need to visit bar.

There is a big variety of mechanized bartenders[1], which are supposed to solve the problem of making fine cocktails automatically, as they could be done by barmen[2], but each of existing analog has disadvantages. Many of these bartenders need daily cleaning, can not offer a big choice of cocktails, are too complicated in use. But the main problem is that all of them are extremely expensive, so that it does not make any sense in buying such device.

My goal is to develop a cocktail machine, which is going to be as simple, as possible to reduce the price to appropriate level, so that it will be available for potential customers. Still, the device should provide an ability to produce a large variety of cocktail on a high speed and precision.

2. Background

The main problem is to combine the simplicity and performance of the machine so, that with such balance the cocktails machine will produce cocktails with the accuracy of the existing analogs or even better, but will be much cheaper.

As there is no special literature about this topic, research work is done only by searching machines, that were created before to make an overview of all the solutions. The list of main requirements for my project is given below:

- choose an appropriate beverage dispensing system [3]
- choose the material of the device
- find the easiest solution of mixing drinks in correct proportion.

3. Methodology

A rounded model is chosen because it looks nicer, than models, where bottles are set in a row. The objective for the machine is to be able to make cocktails using 14-18 bottles.

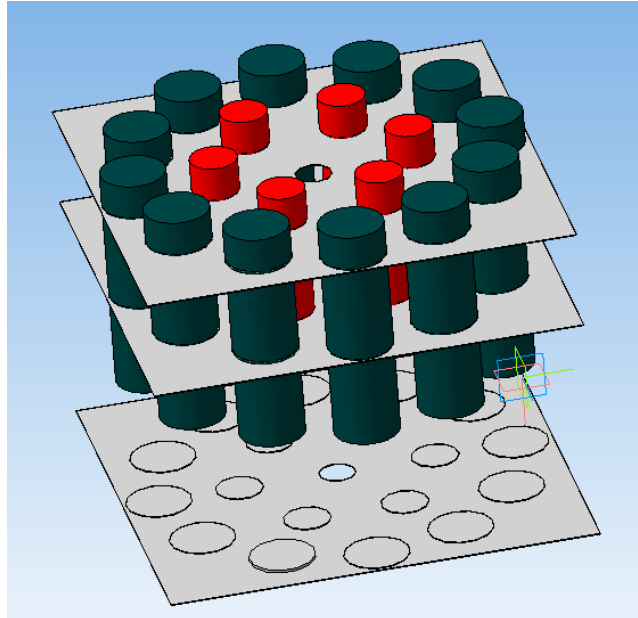

Figure 1 An expected disposition of bottles

Liquid dispensers will be used, as there are cheaper and easier in use, than pumps [4]. Such dispensers pour out an exact amount of liquid each time, they are pushed.



Figure 2 Beverage dispenser

The success of the research will be measured according to how the solution I provided is providing better results, in terms of performance, functionality and price.

4. Research schedule:

No	Task description	Deadline
1.	Overview of existing analogs of Cocktails machine	14.12.2016
2.	Formulating the requirements of the device	29.01.2017
3.	Building a 3D model, Material, motor selection	29.03.2017
4.	Strength calculation, weight calculation, model optimization	16.04.2017
5.	Development of the algorithm of working processes,	09.05.2017

5. References

- [1] online «Somabar» <https://www.kickstarter.com> 06.02.2017
- [2] G. Regan «The Joy of Mixology» 2003 «Random House USA Inc.»
- [3] online «Hands on» <http://ieeexplore.ieee.org> 04.02.2017
- [4] L. Hamill «Understanding Hydraulics» 2011 «Palgrave»

Additional data and requirements:

Language: English

Student: “.....”201.....

/signature/

Supervisor: “.....”201.....

/signature/

CONTENTS

PREFACE	9
CHAPTER 1.....	11
1.1 Introduction	11
1.2 Motivation.....	11
1.3 Overview of the thesis.....	12
CHAPTER 2.....	13
2.1 Background review	13
2.2 Existing analogs of cocktail machines.....	15
2.2.1 The Qube	16
2.2.2 Somabar.....	17
2.2.3 Monsieur	18
2.2.4 Bartesian.....	20
2.2.5 Omnia.....	21
2.2.6 Bartendro	23
2.3. General overview.....	24
CHAPTER 3.....	26
3.1 Necessary parameters of cocktail machine.....	26
3.2 Frame and case	28
3.3 Flasks.....	31
3.4 Dosing of beverages	33
3.5 Funnel.....	34
3.6 Platform	38
3.6.1 Belt drives	40
3.6.2 Stepper motor.....	42
3.7 Vertical moving rack	44
3.8 Arduino	45
3.9 Liquid measuring.....	47
3.10 Sensors	48
3.11 Basic principle of work	51
CHAPTER 4.....	53
4.1 Stepper	53
4.2 Materials of driving belts	54

4.3 Calculation of the parameters of the vertical rack.....	56
4.3.1 Choice of the stepper for the vertical rack	56
4.3.2 Belt parameters.....	59
4.3.3 Calculation of wear resistance.....	60
4.4 Calculation of the parameters of the platform	60
4.5 Calculation of the load on the vertical rack	65
4.6 Economic calculation.....	67
SUMMARY	69
LIST OF REFERENCES	71

PREFACE

I would like to thank the Department of Mechatronics of the ITMO University for the great opportunity to study in Tallinn University of Technology. I am paying my respects to my supervisors: professor Mart Tamre and Stanislav Reznikov and thank them for their support, acclaiming and assistance during my work.

EESSÕNA

Tahaksin tänada, et Mehhatroonikainstituut on loomud ITMO Ülikooli jaoks suurepärase võimaluse õppida Tallinna Tehnikaülikoolis. Ma hindan minu juhendajaid: professor Mart Tamret ja Stanislav Reznikovi ja soovin tänada neid nende toetuse, nõuannete ja abi eest minu töö valmimisel.

CHAPTER 1

1.1 Introduction

These days many people go out to bars expecting to get served in a timely manner, however, on busy nights this is a difficult task for the bartenders to accommodate many people. And whether it is possible to be sure what the bartender won't spare on something that afterwards can lead to the conflict and harming to reputation of an institution? Most bars at their busiest time need help getting all the drinks out in a timely manner. Many places are reluctant to hire more staff, especially when there is limited space behind the bar. This, combined with the fact that wait staff cannot make cocktails for their customers, often leads to customers having to wait a long time to receive their order. There are a lot of places of self-service where occasionally it is simpler to make cocktail than to wait for the waiter.

Market offers us a huge amount of different devices and gadgets, which are supposed to make our life easier and more convenient. Cocktails machines and robot bartenders are not an exception. The device about which there is a speech is called a dispenser - mixing alcoholic beverages, and is intended for manufacture of various alcoholic cocktails.

They are designed as for placing in clubs and bars for acceleration and accuracy of drinks extradiation, or for using at homes to get a fine drink without any need to visit bar.

My goal is to develop a cocktail machine, which is going to be as simple, as possible to reduce the price to appropriate level, so that it will be available for potential customers. Still, the device should provide an ability to produce a large variety of cocktail on a high speed and precision. The target market for the product is late night establishments that have a higher frequency of being full for extended periods of time.

1.2 Motivation

I believe, that an automated cocktail mixer can eliminate several problems, appearing in nightclubs or just in cases of drinking alcohol. With such machine it is possible to serve more customers during a busy night, therefore bringing in more revenue and standardize the amount of alcohol

poured into each drink which generally allows more drinks to be made from a single bottle. Such cocktail machine could be a showpiece, that attracts more customers, and finally, it is just convenient, as the electrical coffee machine.

1.3 Overview of the thesis

Chapter 2 is necessary to give an overview of existing analogs of cocktail machines. It starts with another variants of mixing cocktails, and finishes with the comparison of the produced machines.

Chapter 3 is giving a full description of the developed cocktail machine. It provides information about used mechanisms, materials and how the machine is going to mix cocktails. It also gives a little inside information about the controlling of the machine and working algorithms.

Chapter 4 provides information about calculations of belt drives, steppers and durability of used material. Economic calculations are also provided.

CHAPTER 2

2.1 Background review

Throughout the country, many restaurants have adopted the use of pre-mixed cocktails. These drinks are pre-mixed and served in a machine, that constantly stirs the cocktail mixture. It also has a nozzle for dispensing the drink. A common example is the frozen margarita cocktail dispensers. Many other pre-mixed cocktails are available for purchase by the bottle.[1]



Figure 2.1 Example of pre-mixed cocktails [1]

For many years engineers are trying to build a humanoid robot, which could be able to perform duties of a barmen-talk, serve, take the orders, mix the drinks. And some projects are successful enough to carry out the work, but still, with the help of people.



Figure 2.2 'Karl' in 'Robots Bar & Lounge', Ilmenau, Germany [1]

The exception is a machine called «Makr Shagr». Designed by researchers and engineers at MIT Senseable City Lab, Cambridge, and implemented by Carlo Ratti Associati in collaboration with The Coca-Cola Company and Bacardi Rum, Makr Shagr was finally unveiled at Google I/O.[2]

Makr Shagr is a new robotic bartending system that allows users to create, in real-time, personalized cocktail recipes through a smart phone application and transform them into crowd-sourced drink combinations. The cocktail creation is assembled by three robotic arms, whose movements – visualized on a large display positioned behind the bar – mimic the actions of a bartender, from the shaking of a martini to the thin slicing of a lemon garnish. The system explores the new dynamics of social creation and consumption – ‘design, make and enjoy’ – and in just the time needed to prepare a new cocktail.[2]

Instead of trying to replace a bartender with a robot, Makr Shagr is a social experiment that looks at how people might embrace the new possibilities offered by digital manufacturing. In Makr Shagr, social connections are woven throughout the co-creation and mixing of ingredients, which are then fed back to the user through the app. With this new technology, consumers can learn from each other, sharing connections, recipes and photos on social networks. Furthermore, Makr Shagr can monitor alcohol consumption and blood alcohol levels – something beyond what a traditional bartender can do – hence promoting responsible drinking.[3]

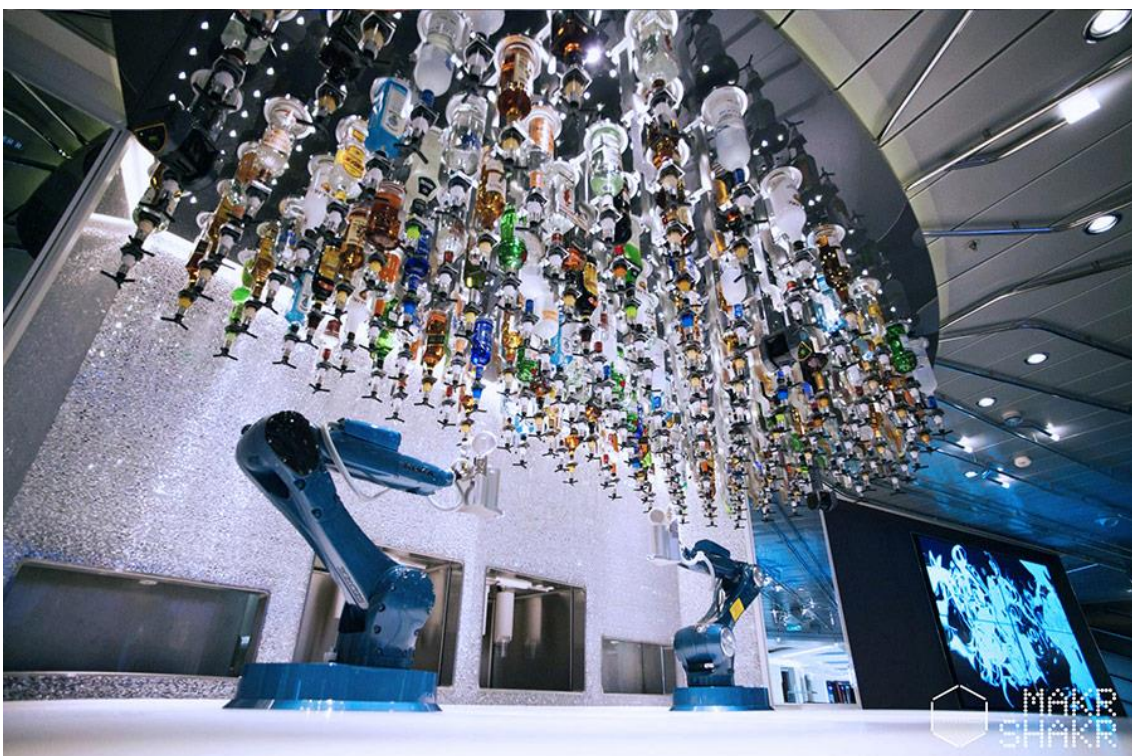

Figure 2.3 ‘Makr-Shagr’ [2]

Launched in 2014, the Makr Shkr Company aims to empower people with new robotic interactions, especially in the food and beverage sector. The company is dedicated to three core values: creativity, simplicity, enjoyment.

The Makr Shkr bar system was designed by award-winning practice Carlo Ratti Associati, combining future robotics with Italian design roots. The recipient of many awards – including D&AD and Core77 – it was developed in the city of Torino, Italy, the birthplace of Martini and Vermouth. Today Makr Shkr bar system continues with cocktail innovation.[3]

2.2 Existing analogs of cocktail machines

There is a big variety of mechanized bartenders, which are supposed to solve the problem of making fine cocktails automatically, as they could be done by barmen, but each of existing analog has disadvantages. Many of these bartenders need daily cleaning, can not offer a big choice of cocktails, are too complicated in use. But the main problem is that all of them are extremely expensive, so that it does not make any sense in buying such device.

There are not any alcoholic dispensers in mass production, but only the presentations of self-made constructions, which are made very professional. As there is no special literature about this topic, research work is done only by searching machines, that were created before to make an overview of all the solutions.

It seems, that three main types of alcoholic dispensers are produced:

1. "Printer". Bottles with alcohol are set in a row (upside down), and the glass is on a mobile site. On the display the necessary cocktail is selected, and a dispenser itself will mix all components in the sequence and doses set by the program.
2. Roundabout". In this case, a glass stands still, and bottles in the device are set on a roundabout. In case of arrival of a command, the roundabout begins to turn a certain bottle to a glass and doses a certain amount of liquid.
3. "Coffee machine". Here nothing is twisted and moved. All tubules from each bottle are reduced to one place (the place where there is a glass). And in case of arrival of a command, special pumps begin to dose liquid in a glass.
4. Capsule cocktail machine

Examples with short descriptions of the most interesting cocktail machines are given below.

2.2.1 The Qube

The Qube is the most state of the art solution out in the market to date. It is similar to the revolving drink dispensers but it is automatic. It also has a scroll knob interface for selecting the desired drink. All the bottles are gravity fed, like the drink dispensers, but they are placed inside an enclosure. After a selection has been made the machine checks for a glass, rotates to the appropriate bottle, dispenses, then rotates to another bottle is necessary. To change the bottles in the machine, there is a side door that allows access to the enclosure. This device appears to be more of a show piece than a useful tool in a busy bar. The amount of time it takes to select a drink and then rotate to the appropriate bottles is excessive. The time it takes to replace an empty bottle is increased due to the carousel and enclosure.[1]

At the press of a button "The Qube" mixes cocktails and long drinks from up to 12 bottles. The bottle in question is moved to the dosing mechanism by turning the carousel. This mechanism is the centerpiece and, equipped with two plain bearings, it operates the dosing device on the bottle.[4]



Figure 2.4 'The Qube' [4]

2.2.2 Somabar

It's a large, white plastic and hardwood device, with an recess in the front big enough to fit a normal-sized martini or collins glass, and three, 750ml clear plastic cylinders affixed to either side. Those airtight cylinders, known as Soma Pods, are where the Keurig comparison comes in. They hold the liquor and mixers and can be easily stored in the refrigerator for safe keeping (and chilling). They're also the key to Somabar's licensing ambitions.[5]

For now, however, the containers are manually filled, as is the 150ml bitters pod which is placed under what looks like a large silver button on the top of the machine. Users can add, adjust or choose from a series of pre-loaded cocktail recipes in an accompanying smartphone app. Once a user has selected just the right drink, the machine goes to work, pumping precise ingredients from the appropriate pods into a mixing chamber where it marries the ingredients through a proprietary "combination of fluid dynamics, kinetic energy, and turbulence created by static vanes," before dumping the final concoction into a glass all in a matter of seconds. As kitchen appliance go, it's a beautiful, minimal and simultaneously complex machine. As a replacement for fully functional bar setup, it falls flat on a number of levels.[5]



Figure 2.5 Somabar [5]

The first sign of Somabar's limitations came when the company's CTO, Ammar Jangbarwala, dropped a cube of ice in a martini glass while prepping the machine to make a Manhattan. In order to avoid added cost, the company opted not to add a cooling element. You can chill the Soma Pods separately, but failing that, you'll either have to add ice to your drinks or live with luke warm libations. For those who prefers their drinks straight up that could be a deal breaker. What it will do is throw together up to six different liquids (and an optional spray of bitters) in a matter of seconds. As a \$430 party trick, it's pretty damn neat, but it doesn't truly deliver on its promise to effortlessly bring the cocktail revolution home. That's not to say there are no benefits to the Somabar.[6]

Somabar uses fluid dynamics, kinetic energy, and turbulence to mix your bitters or syrups into the alcohol. To ensure that each drink maintains its unique and handcrafted qualities, Somabar uses a self-cleansing mechanism to flush the system of the previous drink.[5]

Even though Somabar is meant for the home, recipes don't have to stay private. Users can share and promote their cocktail recipes to the Somabar community via the app. This social feature, along with its affordable price and precision mixing, differentiates Somabar from all other at-home cocktail mixers.

To prepare Somabar for use, you will need to transfer spirits from their bottles to a Soma Pod, a cone-shaped container that can plug onto designated compartments in the appliance. It can hold six Soma Pods at a time (so up to six different spirits, three on each side), along with a smaller container for bitters set up on top. The device can mix any of 200 cocktails in its database.[6]

2.2.3 Monsieur

The Monsieur is a boxy tabletop device that works like a vending machine for cocktails. Punch in your order on a colorful touchscreen or order from your phone, and the machine will blend liquor with mixers and pour them into your cup. When fully equipped, Monsieur can make up to 300 types of drinks.

"It's very intuitive, simple to use and easily programmable to your drink preferences," said Libby Panke, who tried the machine at a recent launch event in Atlanta. Panke requested a seasonal recommendation and received a vodka and orange juice, which she said was "very good."

The device is the brainchild of Barry Givens, co-founder and CEO of Monsieur, the startup behind the machine. Givens came up with the idea for a "robotic bartender," as he calls it, while struggling to get a drink at a crowded bar one spring during the NBA Finals. He and fellow Georgia Tech alum Eric Williams, Monsieur's chief technology officer, designed the machine after a fundraising campaign on Kickstarter.[7]



Figure 2.6 Monsieur [7]

The Monsieur measures 20 inches high and 21 inches wide and bears a color Android touchscreen allowing customers to browse and order drinks from up to eight mixers and liquors. The touchscreen controls coolers, pumps, sensors and other mechanical components to blend ingredients and deliver your drink. Beneath the touchscreen is an opening where you place your cup. A sensor prevents the drink from pouring until the cup is in place.[7]

Each Monsieur comes with 12 themes, such as "bachelorette party," "Irish pub" or "cigar bar," and each theme offers 20 to 25 drink selections. The machine offers only liquor-based drinks, but its creators are open to adding beer, wine and Champagne. Consumers can also create themes and drinks and share them with others via social media.

A removable power cord attaches to the rear of the machine, but there's also a rechargeable battery, which we're told should last about six hours, so wire-free mobility is a bonus. The dispenser compartment sits along the bottom of the front panel, with cup sensors off to the left side of the tray.[7]

Front and center you'll find a cutout that holds a Nexus 10 tablet and serves as the main interface running the Monsieur app. (The four-bottle version excludes a tablet, but a smartphone app

duplicates all functionality.) It's pre-loaded with drink profiles like Tiki Bar, Mardi Gras and Irish Pub (each can make between 10 and 25 drinks, depending on the number of bottles installed), and lets you adjust the mix of ingredients on the fly or in your profile settings. Dispensing can also be timed for specific ingredients, for instance, letting you float grenadine on top for a Tequila Sunrise. There are even more smart features baked in, including one that lets you schedule a cocktail to appear just as your favorite TV show begins. There's also a "surprise me" mode if making a decision just isn't your thing.[8]

- 4 or 8 liquid container capacity. Each container holds 30oz of any of your favorite spirits, mixers, juices, liqueurs or even wines.[8]

2.2.4 Bartesian

A company called **Bartesian** has developed the world's first Keurig-style machine that uses pre-mixed, recyclable capsules to create quick cocktails at home.

For some, the appeal is obvious. To make a cocktail, you stock Bartesian's glass reservoirs with your spirits of choice (up to four at a time), insert a flavor capsule, select your preferred strength—from mocktail to double shot—and press a button. The Bartesian team claims that each capsule is made with real, premium ingredients like fresh juice concentrates, non-alcoholic liqueurs and bitters. Bartesian's cocktail developers apparently avoid artificial powders and corn syrup and have attempted to create cocktails that "exactly how your local mixologist would make them." [9]

Company hasn't developed capsules for whiskey-based cocktails yet (only vodka, gin, rum and tequila. For now, the available flavors include three classics like the Cosmopolitan and Sex on the Beach and three signature concoctions, including the Bartesian Breeze, made with fruit juices and coconut water.[9]



Figure 2.7 'Bartesian' [9]

2.2.5 Omnia

The development of these machines has started in 2012 and they are now among the most developed cocktail and long drink dispenser in the international comparison. These dispensers allow you to serve your customers alcoholic and non-alcoholic cocktails in the blink of an eye and hence expand your product portfolio by some very profitable beverages: cocktails and long drinks! [10]

Omnia – the features:

The many features of our Omnia cocktail and long drink dispensers make the machines an efficient support to the restaurateurs and their employees.

The features of the machines range from the linking of multiple dispenser units over the in-built „easy clean“ system to many other user and restaurateur friendly functions, which were designed to support your daily life in the busy and stressful hospitality industry as much as possible. [10]

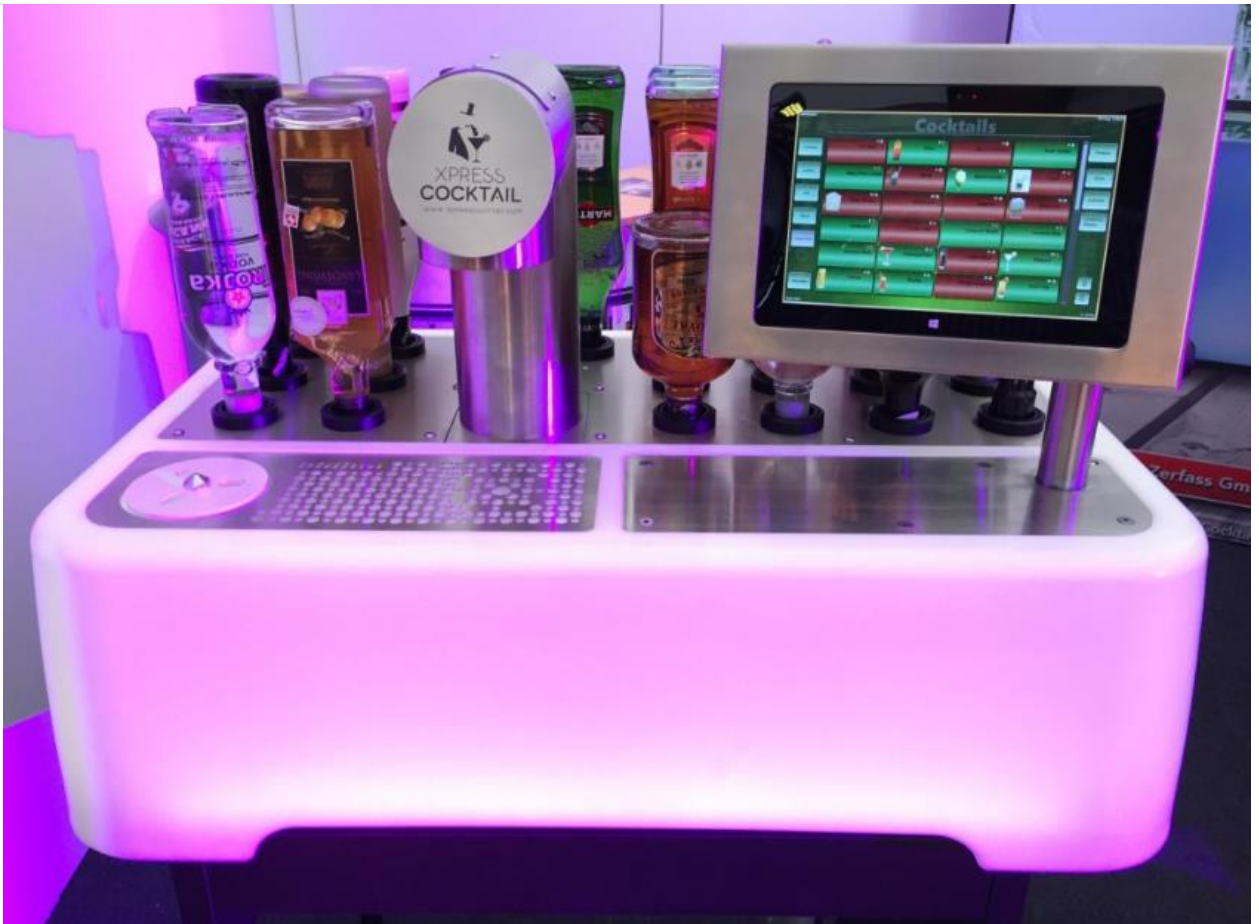

Figure 2.8 'Omnia' [10]

Advantages of an Omnia dispenser:

- Dispensing of Cocktails from fresh individual ingredients in less than 10 seconds
- Simple operation without bartender skills
- Consistent quality of the Cocktails
- Production costs of less than € 1.00 per Cocktail
- Simple integration due to its compact design
- Premium gastronomy quality
- More than 100 pre-programmed Cocktails[10]

2.2.6 Bartendro

Bartendro is a project on a 'Kickstarter', which finally was born to a completed product.



Figure 2.9 'Bartendro' [11]

Liquids only pass through food-grade tubing, not moving parts

Special admin screens let you manage dispensers, ingredients and drink recipes. This is where calibration, customization and cleaning take place. We use peristaltic pumps which dispense a known volume with every revolution of the motor to precisely meter our drinks.

Each pump combined with our custom electronics is called a "dispenser." The dispenser boards use the same processor as an Arduino and connect through a RJ-45 connector to a "router board" which carries the Raspberry Pi (RPI) computer. Any normal networking cable will work, but we've custom made the cables that come with Bartendro to be just the right length. [11]

Router boards can handle up to 15 dispensers, while miniRouter boards can handle up to 3 dispensers.

The RPI sets up a wireless access point and creates a WiFi network called Bartendro.[11]



Figure 2.10 peristaltic pump of 'Bartendro' [11]

2.3. General overview.

This table is made according to the personal view and opinions of interviewed people.

Table 1 A comparison of cocktail machines

Name	Design	Speed of mixing	Convenience	Variety	Price
The Qube	Attractive	Low	Low	Big	11000 \$
Somabar	Elegant	Medium	Medium	Small	429 \$
Monsieur	Elegant	Medium	High	Small	1500\$
Bartesian	Elegant	Fast	Low	Small	389\$
Omnia	Medium	Fast	Medium	Medium	6000\$
Bartendro	Disgusting	Fast	Low	Big	3700\$

As it is seen on the table, each existing analog has its advantages and disadvantages. Different methods of mixing are used, designs also diverse, but one point is the same-prices for the existing cocktail machines are extremely high. The cheapest one is Bartesian, but it is necessary to buy capsules for this machine, 20\$ per 12. This means, that after three or four months of intensive use it will become unprofitable.

The effort of this project-is to find the best solution of mixing cocktails by the machine.

The main problem is to combine the simplicity and performance of the machine so, that with such balance the cocktails machine will produce cocktails with the accuracy of the existing analogs or even better, but will be much cheaper. The list of main requirements for my project is given below:

- choose an appropriate beverage dispensing system
- choose the material of the device
- find the easiest solution of mixing drinks in correct proportion
- keep in mind, that the price should be affordable for a customer.

CHAPTER 3

3.1 Necessary parameters of cocktail machine

The structure of the mechanism is created in the way, to satisfy next parameters:

-Accuracy. The first main requirement for this project is accuracy. This design is aimed at bar owners who operate at a thin margin. If this machine was not able to pour the correct size drink, the owner could begin to lose money very quickly due to serving too much alcohol per drink. Another way this could affect the owner is if the drinks are made with too little alcohol, which could make customers unhappy.

-High performance, higher, if possible, than the existing analogs;

-Precision. Similar to accuracy, precision is a very important requirement for the design. In this situation it is desirable to have every drink come out to be the same. When a customer orders a drink, they expect to have it taste the same every time, and if the machine is not precise, then it will not be able to make consistent drinks.

-Small weight, so it will be possible to transport the machine without any trouble;

-Reliability. In order for this machine to solve the slow cocktail serving problem, it needs to be constantly operational. Therefore, good reliability is a key requirement for the machine. In order to ensure good reliability, it is essential for the system to be simple and have few error mechanisms.

-High capacity of beverages;

-Big variety of cocktails, that could be produced;

- The bottles should be easy to reach for quick exchange.

-Low price;

-FDA Regulations. This machine will be used in beverage service, which is regulated by the Food and Drug Administration. Therefore, it is a requirement that all parts that come in contact with the fluids are FDA certified for this service.

Trying to achieve the combination of all parameters above, and inspired by existing analogs, the concept of the cocktail machine was implemented to the 3D-model, which is given below.

The height of this cocktail machine is 700 cm, length-500 cm, width -550 cm, which means, that the size is practically the same, as a professional electric coffee machine, and even smaller, then many existing analogs of cocktail machines. It is equipped with 12 flasks, standing in a circle, which means, that with full loading it can produce from 70 to 85 cocktails.

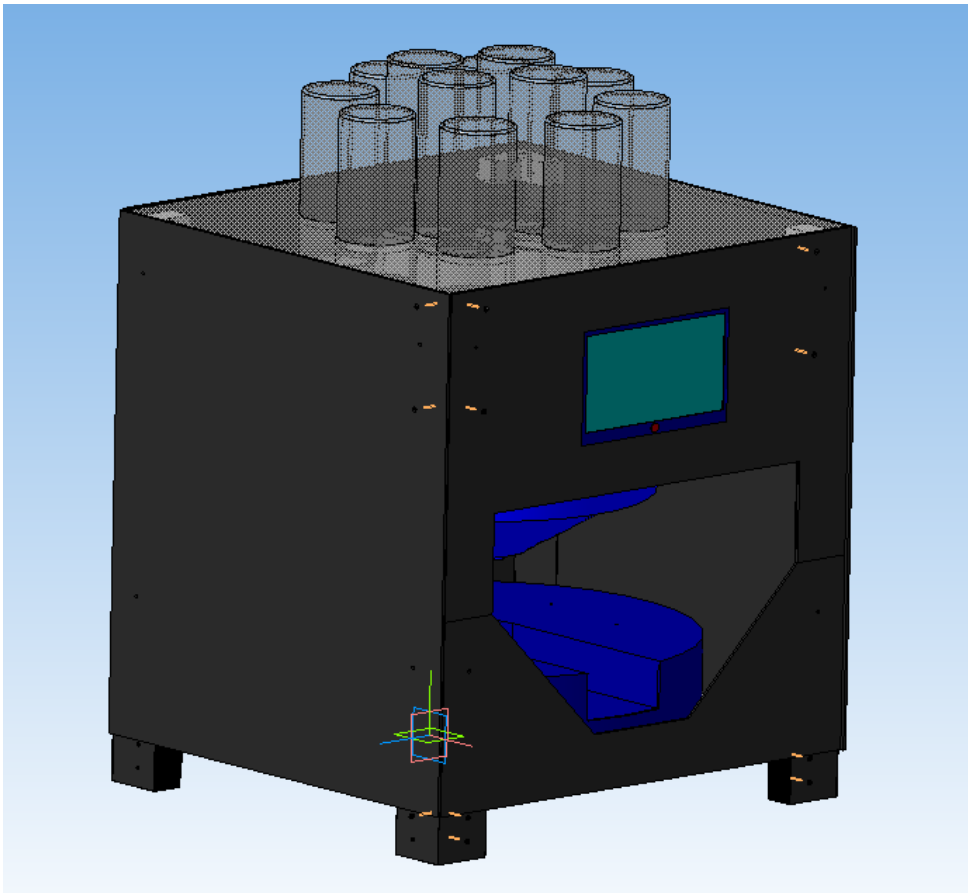

Figure 3.1 Appearance of the Cocktail machine

The dosing system is implemented by 12 dispensers, connected to the bottles. By pushing on each dispenser, a dose of beverage flows in the funnel, and from it-to the glass or shaker, set by a user. Mechanism of pushing on a dispenser is realized by two belt drives. Further information and description is given below.

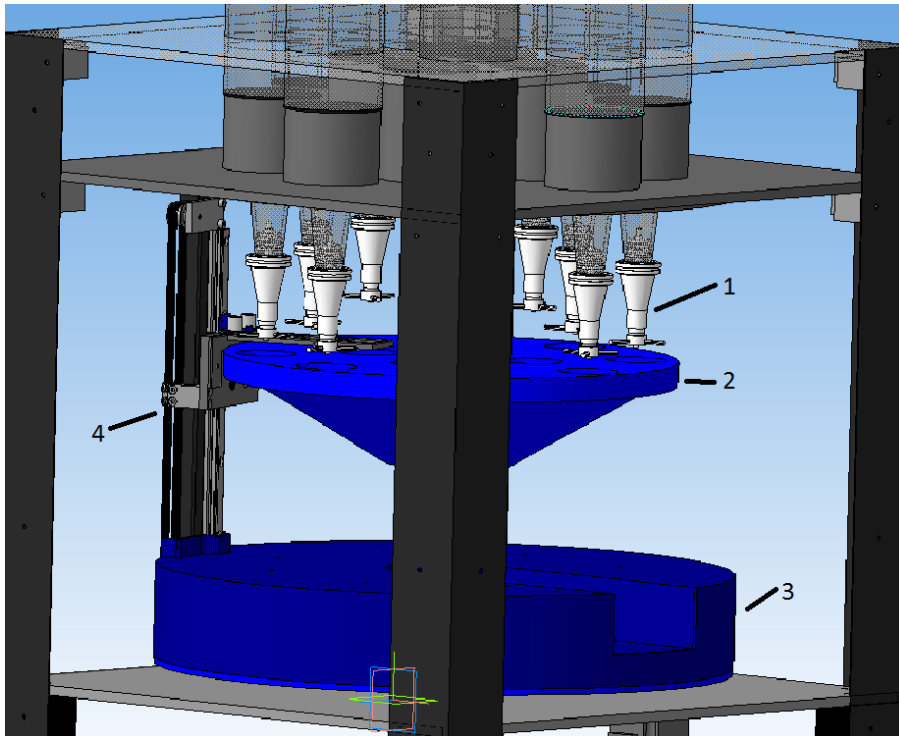

Figure 3.2 Appearance of the Cocktail machine without a shell

1-Dispenser; 2-a funnel; 3-platform; 4-vertical moving rack

3.2 Frame and case

As it is possible to put up to 12 flasks of beverages in the cocktail machine, it means, that the frame of the machine should be able to withstand a heavy load and be, at the same, lightweight to reduce the whole weight. According to these parameters, duralumin was chosen as a frame material.

Duralumin is an alloy, a trade name given to the earliest types of the age harden able aluminum alloys. It is an alloy made up of 90% aluminum, 4% copper, 1% magnesium and 0.5% to 1% manganese. It is a very hard alloy. These alloys are used in places where hard alloys are required, for example in the vehicle armor that is used in the defense industry. These alloys were the first widely used deformable aluminum alloys.[12]

Duralumin is a strong, light weighted and hard alloy of aluminum. It is also reflective and impermeable. It is a malleable metal, and can be easily shaped. It is a very good conductor of heat and electricity. It is odorless, and reacts with the oxygen that is around, and forms aluminum oxide. It is resistant to corrosion. It has a thin surface, which is made up of a layer of pure aluminum, which is corrosion resistant, and covers the core of the strong duralumin. Generally, Duralumin alloys are soft, ductile and workable when they are in normal state. They can be easily rolled, folded or forged. They can also be drawn into a variety of shapes and forges. It has a high strength,

which can be easily lost during welding. So it can be easily transformed, and hence is used in aircraft construction. It is suited for aircraft construction because of its lightweight and high strength..[12]

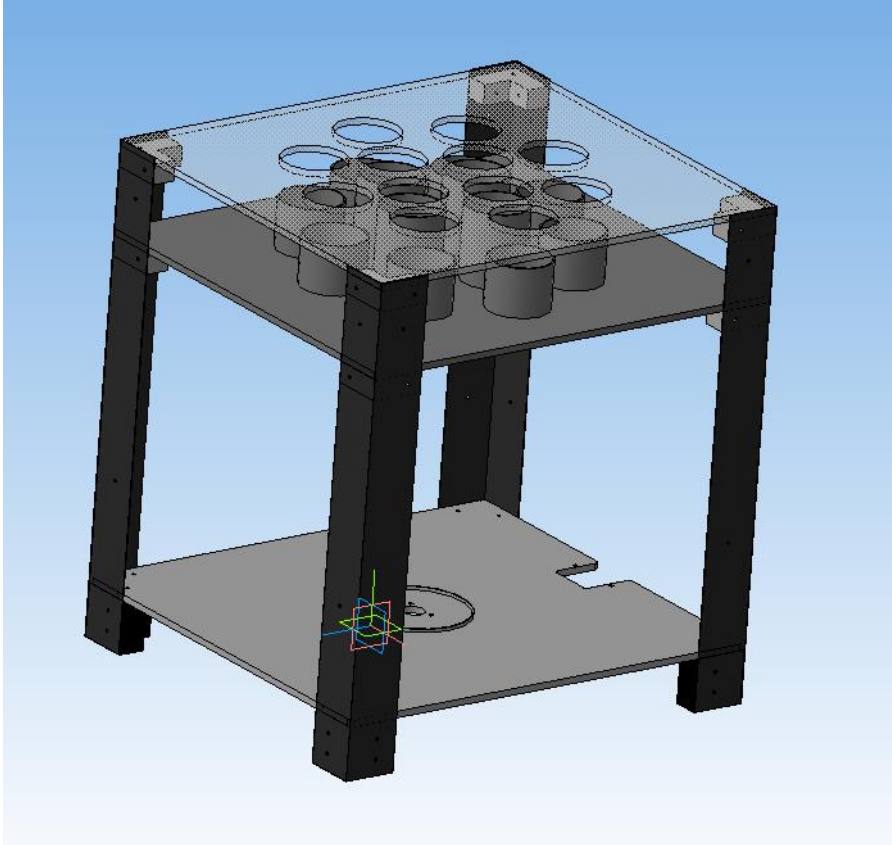

Figure 3.3 Frame and platens

Duralumin is used for the bottom and middle platen of the machine, also as the racks on the corners.

For the upper platen polycarbonate was chosen, because of its transparent ability, which allows to measure the rest of spirits in the flasks visually. Main advantages of this material are:

- low thermal conductivity
- high durability when bending;
- small weight;
- excellent constructional abilities, which provide simplicity and reliability even in the most difficult designs;

-high light-transmitting qualities

Polycarbonate – the thermoplastic constructional polymeric material having high rigidity and durability in combination with very high resistance to shock influences including at the increased temperature. Has good optical properties, a high heat resistance, insignificant water absorption, high electrical resistance and breakdown strength, insignificant dielectric losses in a broad range of frequencies. Products from polycarbonate save stability of properties and the sizes in a wide interval of temperatures: from -100 to +135 °C.

It is steady against effect of water solutions of mineral and organic acids, gasoline, alcohols, oils, but isn't resistant to alkalis, the concentrated acids, organic solvents. Besides, details with high residual stresses easily crack in case of effect of gasoline and oils. The long influence of hot water is undesirable. It is inclined to hydrolysis, requires good drying before processing.

In ecological parameters polycarbonate doesn't concede to such materials as glass, and much more surpasses him in durability. Its properties change with growth of temperature, and critically low temperatures leading to fragile destructions are outside of possible temperatures of operation.

Strength, transparency, stability of properties and the sizes of polycarbonate in a wide interval of temperatures caused its broad application in many industries as constructional thermoplastic polymeric material instead of non-ferrous metals, alloys and silicate glass.

The case is made from shock-resistant Polystyrene. Polystyrene – amorphous polymer firm on the state, belonging to group of thermoplastics. Polystyrene is received from styrene – an oil synthesis product. Receiving of the material is based on process of continuous polymerization of styrene. Industrial production releases polystyrene granules which size varies from 2 to 5 millimeters.

Shock-resistant polystyrene (UPS) – the material received by polymerization of rubber and styrene. This material differs in resistance to shock loadings, but isn't steady against loads of stretching, and also usual polystyrene possesses lower threshold of a softening, than.[13]

Characteristics of polystyrene

- Quite good frost resistance (transfers temperature -40 degrees);
- Environmental friendliness (it isn't dangerous to the person);
- Weak resistance to ultra-violet radiation (needs additional protection);
- Chemical firmness (practically doesn't give in to influence of acids and alkalis);
- Excellent electroinsulating properties (quite good dielectric);

Polystyrene is softened at a temperature above 95 degrees Celsius. Vapor permeability considerably worsens at a temperature below 0 that allows to use polystyrene for packing of food

This kind of polystyrene is characterized by the increased crash-worthiness (concedes only to polycarbonate), ease in processing. Shock-resistant polystyrene happens various flowers to an opaque or glossy surface. Scope of shock-resistant polystyrene isn't limited, is most often used for designs of outdoor advertizing, architectural elements of buildings. Sheets of shock-resistant polystyrene can be exposed vacuum and to thermomolding, cutting, drilling, bending, pasting. [13]

3.3 Flasks

It is unacceptable to keep alcohol or other ingredients in plastic, because beverages can react with such kind of materials. Also, keeping alcohol in steel bottles for more, than three days can change the taste of a drink. The best material that suits for keeping alcohol and using it in a cocktail machine is glass. As alcohol drinks are produced in bottles of different sizes and forms, it was decided to find a flask, which will suit the best. The photo and parameters of the bottle are given below.

Weight: 585 g

Capacity: 750 ml

Height: 306 mm

Diameter: 79.5 mm

Color: transparent

The bung on a bottle grants an absence of evaporation of alcohol in case of long keeping. The transparency allows to measure the amount of rest beverages by sight, as flasks protrude from the case of the machine. In advance, flasks of such form can be easily removed from the case to be refilled.



Figure 3.4 Flasks

The flasks are located in two circles in the middle of the cocktail machine, 8 at the external side, 4- at the internal. This is done to reduce overall dimensions of the machine and to add some aesthetic appearance. Flasks at the internal side are raised 30 cm higher to exclude a possibility of pushing on the wrong dispenser or two dispensers at the same time. Rubber gasket is inserted between platen and flasks for higher reliability.

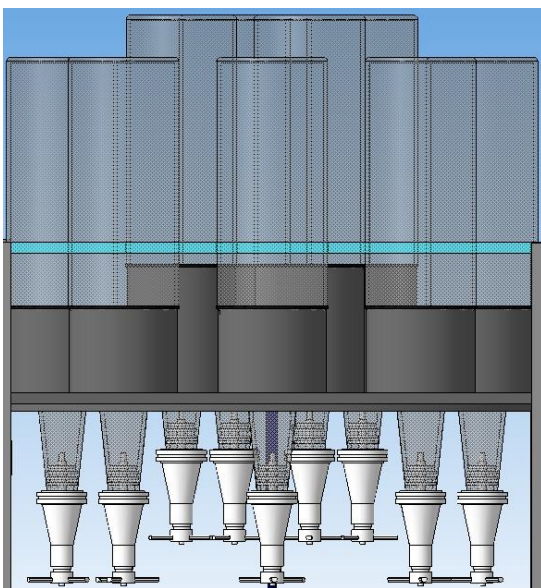

Figure 3.5 Disposition of flasks

3.4 Dosing of beverages

During the research, it was found out, that using pumps for dosing of beverages is too expensive to use, so it was decided to use the dispensing system that is cheaper, than a pump and can give enough precision for making cocktails. The best solution is Bonzer Spirit Dispenser; the photo of it is given below.

«Bonzer» company specializes in the design and manufacture of light catering equipment products for food preparation, serving and portion control, and dispensers for coffee shops, bars, commercial kitchens, caterers, professional chefs and restaurants. It also designs and stocks a wide variety of bar equipment for bartenders, including cocktail shakers, cocktail sets, drinking glasses, wine accessories, barware sets, and other glassware, bar and cocktail accessories. All of their products are designed to be used in the highest standard professional or commercial kitchens. The Bonzer Spirit Dispenser boasts a conical design to provide the most effective and accurate form of dispensing spirits and is available in sizes 15ml, 25ml, 30 ml, 35ml, 45 ml and 50ml. It has been styled for use involving the rim of the glass ensuring a smooth dispense action whilst the single handed operation makes multi-tasking much easier for bar staff reducing waiting time for your customers. These spirit dispensers offer a reliable non-drip mechanism and have been crafted specifically in order to clip into any form of bracket whilst the simple yet smart black design adds a pleasant look to its surroundings.[14]



Figure 3.6 Dispenser

By pushing on the rods at the bottom of the dispenser, it doses an exact amount of beverage, depending on its capacity.

These dispensers are produced from Food-grade ABS Plastic and Aluminum Alloy and can be easily attached to any bottle and dose an exact amount of a drink, which, with low price and small weight, is the best solution, possible to find.

Each bottle is connected to such dispenser, but of different capacities, depending on the beverage in a bottle. This is done for making the ideal proportions of syrups, alcohol drinks, etc. in produced cocktails. Another advantage is, that even connected to the dispenser, flask can be easily removed from the case and changed or stored in a fridge.

3.5 Funnel

The funnel is located just under the dispensers and can be removed from the machine in case of cleaning.

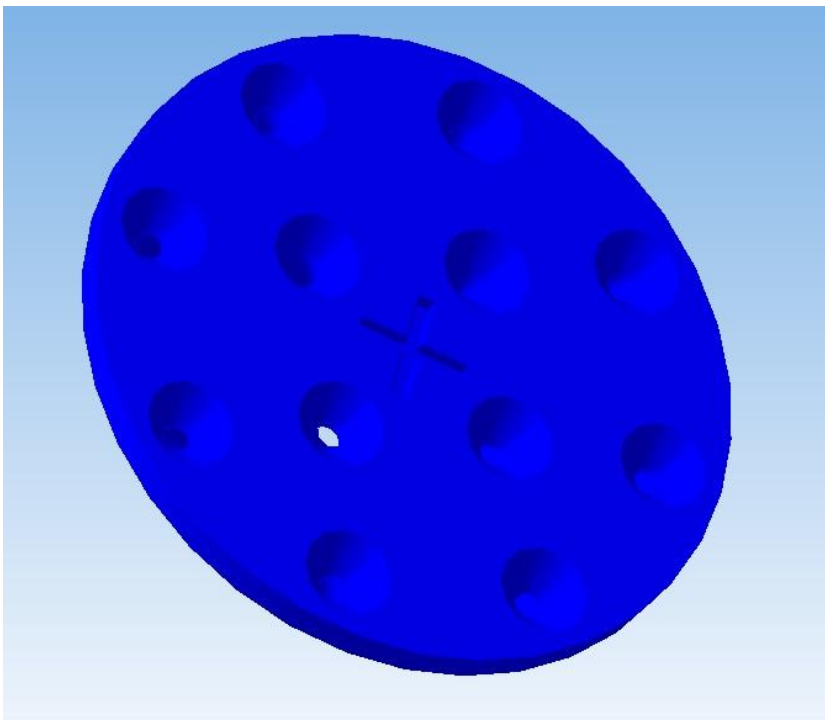

Figure 3.7 Funnel

The channels in a funnel are separated and do not have any connection between each other. This is done in consideration that spirits should not mix with each other even in small portions or drops, due to a huge variety in flavors, tastes and consists. All the outlets of the channels are located at

the bottom of the funnel in 70 mm diameter, which is less than most glasses and shakers, used in cocktail making.

When a dispenser doses a portion of beverage, a spirit moves by direct channel to the glass by forward flow. Each channel belongs to the concrete dispenser, which means, that it belongs to a concrete spirit up to the time of cleaning.

The material for the funnel is a very important point, because it one of the few parts of the machine, that has the direct connection with the spirits. As this part is quiet complicated and must be lightweight, plastic should fit well. There are four organizations, which regulate materials, approved for use in food and spirit area. While designing this product, all components that will be in contact with the liquids need to be certified for that service.

FDA

The food and drug Administration (FDA) is a regulatory agency of the U.S. government, responsible for determining how materials may be caused in contact with food products. The FDA participates in publication of the The Federal Register, which contains The Code of Federal Regulations (CFR), a codification of the general rules established by the Executive departments and agencies of the Federal Government. The Code is divided into 50 titles, which represent a broad subject matter.[15]

USDA

The United States Department of Agriculture (USDA) Food and Safety and Inspection Service regulates manufacturing, packaging and handling practices in the agricultural food industry. Historically, the USDA reviewed material composition and issued "letters of no objection" for materials deemed to be chemically acceptable for their intended application. This protocol is no longer practiced. Current policies for assuring the chemical acceptability of materials used for components of food processing equipment is outline in Accepted Meat & Poultry Equipment Publication (MP1-2, 3818 Directive 11220.0) November, 1993. This policy states that components used in direct food contact must be documented as to their compliance with the Federal Food, Drug and Cosmetic Act ("FDA compliance") by a written letter of guaranty from the manufacturer to ensure that they are formulated in compliance with appropriate regulations. Therefore, USDA requirements for material approval are satisfied by a certification of FDA compliance.[15]

NSF

NSF International, formally known as The National Sanitation Foundation, is an independent, not-for-profit, neutral agency, serving government, industry, and consumers in achieving solutions to problems relating to public health and the environment. NSF Standards for equipment, products and services are developed with the active participation of public health and other regulatory officials, users and industry. NSF publishes Listing Books which identify equipment, products, components, materials, ingredients or services that have demonstrated conformance with NSF

requirements and are authorized for Certification. Materials used for NSF approved devices must often comply with NSF material standards. Three commonly referenced NSF Standards for plastics materials are 14, 61, and 51. NSF Standard 14: Plastics Piping Components and Related Materials applies to thermoplastic and thermoset plastics piping system components in contact with potable water and primarily addresses physical properties of plastic components in piping and plumbing systems. ANSI/NSF Standard 61: Drinking Water System Components – Health Effects covers indirect drinking water additives. This standard addresses health and toxicity effects of plastic resins. NSF Standard 51: Plastic Materials and Components Used in Food Equipment defines the material requirements for food protection, considering extractables using FDA guidelines. [15]

3-A Dairy and Food

3-A was founded in 1920's by three dairy associations in the interest of creating sanitary standards and practices for equipment and systems used to process milk and milk products, and other perishable foods. Today, the 3-A Sanitary Standards Committee are composed of representatives from many government agencies and industries alike. Standard Number 20-17, 3-A Sanitary Standards for Multiple-Use Plastic Materials Used as Product Contact Surfaces for Dairy Equipment has been developed to "...cover the material requirements of plastics for multiple-use as product contact and/or cleaning solution contact surfaces in equipment for production, processing and handling of milk and milk product(s). Test criteria are provided for plastics as a means of determining their acceptance as to their ability to be cleansed and to receive effective bactericidal treatment and to maintain their essential functional properties and surface finish in accelerated use-simulating test..." Samples are subjected to chemicals representative of dairy clearing compounds and measured for weight change and changes in surface appearance. Historically, 3-A has maintained a published list of plastic materials, which comply with Standard Number 20-17. The 3-A Steering Committee has chosen to terminate maintenance of this list. Suppliers achieve compliance with this standard through independent evaluation and self-certification.[15]

The research work has given a material called TECAMID 66 as a result. This plastic is approved by all four organizations.

Table 3.1 Food Compliant Materials Table

PRODUCT	FDA	NSF	USDA	3A
Tecamid 6/6 Natural	21CFR177.1500	Std. 61	Yes	Yes

TECAMID 66 in comparison with TECAMID 6 is more rigid, strong and firm. As well as all Polyamides, TECAMID 66 has good chemical resistance, including to fuel, oils, fats, oil products, to the majority of organic solvent and alkalis. In comparison with other TECAMID 66 polyamides it is more heat-proof (an exception only of PA 46), has larger deformation firmness and rather low moisture absorption. Very good properties of sliding and excellent wear resistance. TECAMID 66

has good electroinsulating properties. One of TECAMID 66 advantages is high fatigue resistance and the increased thermal stability in comparison with Polyamide 6. TECAMID 66 has the good damping properties and resistance to high dynamic loads. TECAMID 66 is used instead of Polyamide 6 in cases where high rigidity and density to the detriment of elasticity are required. Even in difficult operating conditions it very much hardwearing. The slipping details do not require lubricant as it has a natural low coefficient of friction. TECAMID 66 has larger durability at compression and very high stretching voltage. The melting point is much higher, than at Polyamide 6. Polyamide 66 has high resistance to radiative effects (scale and a roentgen). As well as all Polyamides, TECAMID 66 it is capable to absorb moisture from air, but water absorption of Polyamide 66 is lower, than at Polyamide 6, though above, than at Polyamide 12 and Polyamide 11. [16]

Characteristics of TECAMID 66:

- High heat stability (the melting point of PA 66 is higher, than PA 6);
- High durability and hardness;
- High moisture absorption that worsens the most characteristic values to a greater or lesser extent: durability, shock durability of a sample with a cut, resistance to attrition improve while other mechanical and electric properties worsen
- Very good impact strength depending on moisture content;
- Very high chemical resistance, first of all to alkalis, solvents and fuel;
- Sensitivity to cracking only under very dry conditions;

It is also lightweight, which means, that it perfectly fits as a material of a funnel.

In case of cleaning of a funnel, it should be removed from the case of a cocktail machine. A funnel is fixed in the case by the cross, made from the same material, as a funnel.

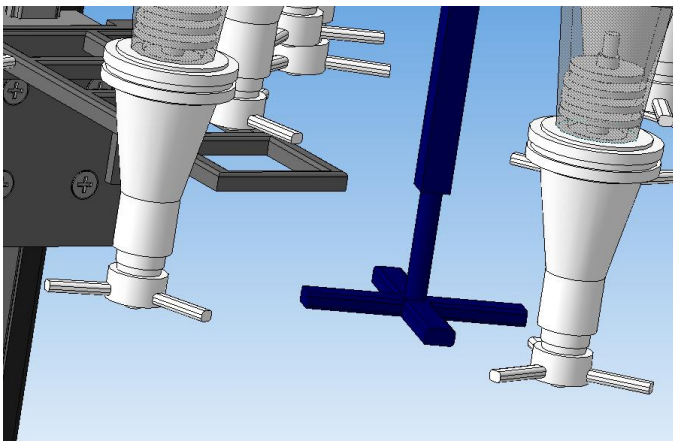

Figure 3.8 Cross-connection

In the center of a funnel a cross hole with gutters is made. So, to fix the funnel in the machine, user needs to fill the cross in the hole of the funnel, and turn the funnel on the angle of 45 degrees. In the case of the machine there is enough space to remove the funnel, clean it, and place back. Cleaning is needed only when the spirits in flasks are changed or placed in a different hole of a machine. There is no need to clean the funnel any time, as the channels for spirits are not connected and this will not change the taste or consist of the cocktails made.

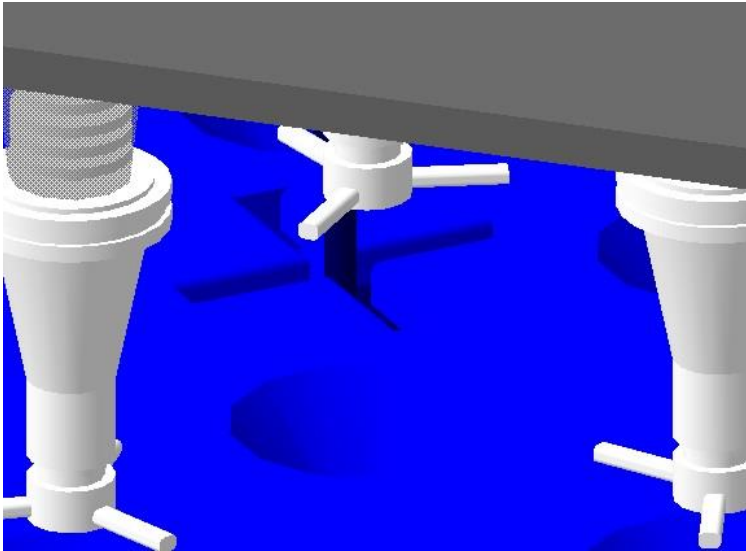

Figure 3.9 Funnel connected

3.6 Platform

The platform of the bottom of the cocktail machine is, probably, the most important part of the mechanism, as it is used for correct positioning of the vertical rack, which, in turn, is pushing on the right dispenser, according to the recipe of the cocktail. This means, that the platform should turn at the correct angle with minimum error.

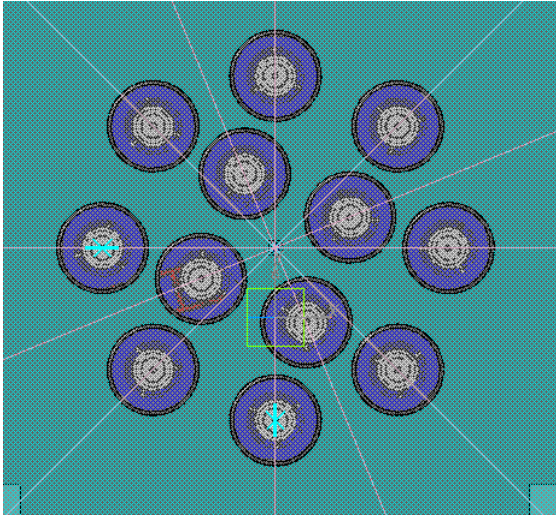

Figure 3.10 Angles

To reach all the goals, the decision was made to use a belt drive with a stepper motor. The pulley of the belt drive is attached to the bigger platform, which has a diameter 470 mm. The vertical moving rack is connected to the platform, Stepper motor is a best solution in that case, because it has high precision and repeatability, normally accuracy is not more, than 5% of a step size, and this mistake does not accrue.

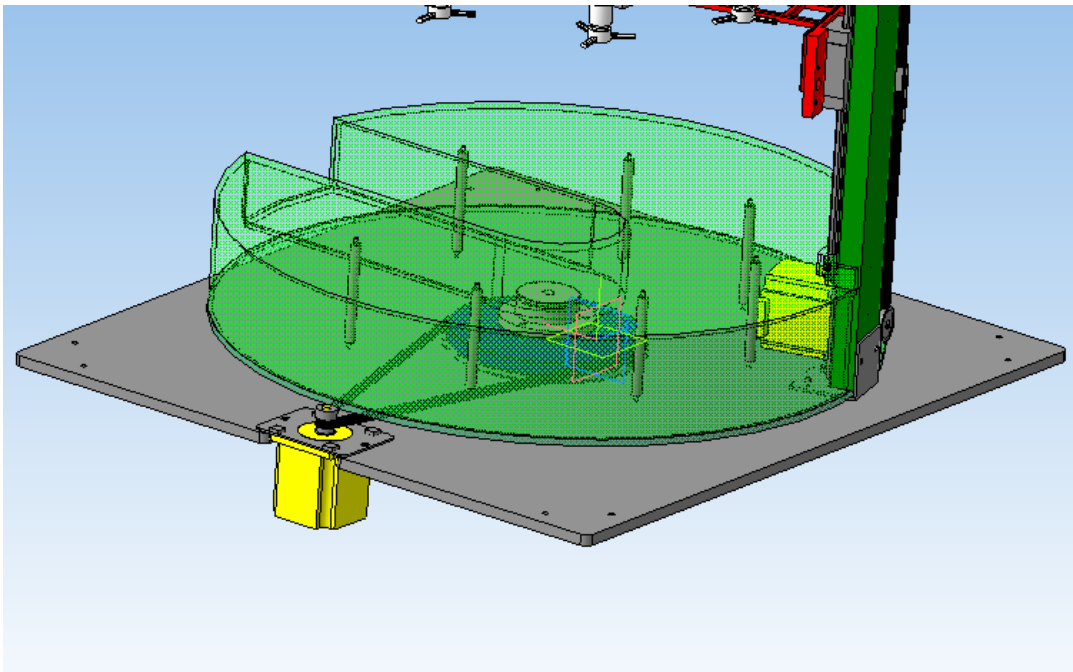

Figure 3.11 Bottom platen

The shell on a platform is made from the TECAMID 6/6- food grade plastic, because there is a possibility of contact with beverages. It covers the electrical parts, located on a platform, and, as it is seen on a figure, the trough is made in shell, so that the user could easily place the glass or shaker straight under the funnel. There is enough space to put a classical shaker or any type of glasses inside.

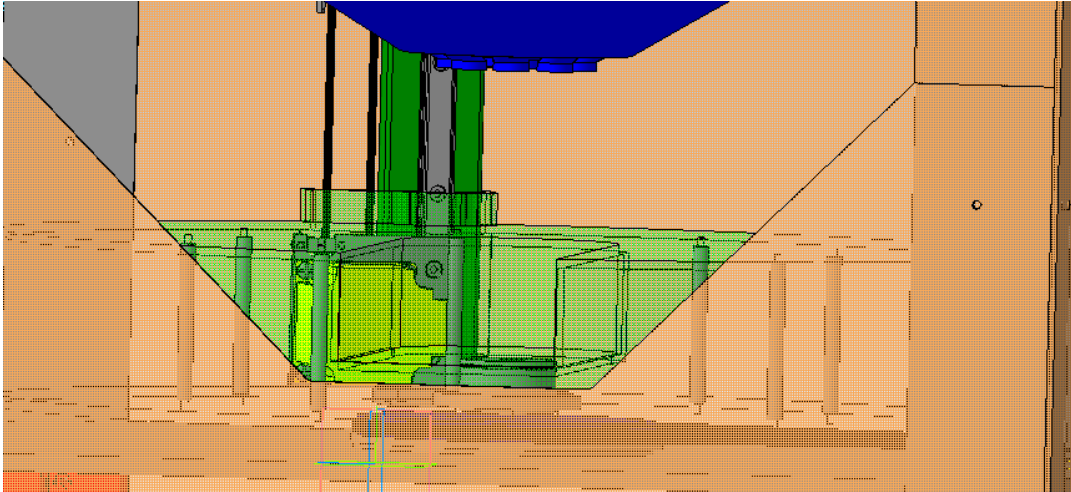

Figure 3.12 The through

3.6.1 Belt drives

The belt drive is a transmission of mechanical energy by means of a flexible element — a drive belt, due to frictional forces or forces of a linkage (cogged belts). Can have both constant, and variable gear number which shaft can be with parallel, crossed and with the crossed axes. Belts shall have rather high strength in case of action of alternating loads, have high friction coefficient in case of movement on a pulley and high wear resistance. Belt drives are used to drive aggregates from electro motors of low and average power; to drive from low-power internal combustion engines. Application of flat-time transmissions is restricted as their operational properties are worse, than belt drives of other types. The exception is made for perspective transmissions with film synthetic belts.[17]

In need of providing the belt drive of constant transfer number, accuracy of rotation and good traction ability it is better to establish gear belts. At the same time the bigger initial tension of belts isn't required; support can be motionless. Flat-time transfers are applied as simplest, with the minimum tension of a bend. Flat belts have rectangular section, are applied in cars which have to be steady against vibrations (for example, high-precision machines). Flat belt drives apply rather seldom now (they are forced out by V-belt). Theoretically, traction ability of a maple belt at the same effort of a tension is 3 times more, than at flat. However, the relative durability of a maple belt in comparison with flat is slightly less (in it less layers of the reinforcing fabric) therefore almost traction ability of a maple belt is approximately twice higher, than at flat. This certificate in favor of maple belts has formed the basis for their wide circulation, in particular recently. V-belts can transfer rotation to several shaft at the same time, allow $u_{max} = 8 - 10$ without tension roller.

Round transfers in mechanical engineering are not applied. They are used generally for low-power devices in instrument making and household mechanisms (tape recorders, radio-gramophones, sewing machines etc.).

The transferred power of power belt drives practically reaches 50 kW, though there are flat transfers with power 1500 kW. Belt speed $v = 5 - 30$ m/s (in superfast broadcasts $v = 100$ m/s). In mechanical drives the belt drive is used most often as the lowering transfer. The maximum transfer relation of $U_{max} = 5 - 6$ for transfers without tension roller and $U_{max} = 6 - 10$ for transfers with a tension roller, allowing a short-term overload to 200%. [17]

Advantages:

- a possibility of an arrangement of the leading and conducted pulleys at long distances (that is important, for example, for agricultural mechanical engineering);
- smoothness of the course;
- noiselessness of work of transfer, caused by elasticity of a belt;
- small sensitivity to pushes and blows, and also to overloads, ability to revolve;
- a possibility of work with big angular speeds to 30 m/s
- protection of mechanisms from sharp fluctuations of loading owing to elasticity of a belt;
- lowered requirements to the accuracy of a relative positioning of shaft of transfer;
- possibility of work at high turns;
- ability of self-protection from unaccounted overloads, thanks to a possibility of pro-slipping of a belt on pulleys;
- simplicity of a design
- low cost.

Disadvantages:

Common faults inherent in all friction gears: need of ensuring considerable efforts of interaction of the elements of transfer necessary for creation of the required values of friction forces, and inevitability of slipping of the interacting elements - are peculiar also to friction belt drives.

- considerable dimensions of pulleys;
- high loads of shaft and support (bearings) because of a belt tension;
- impossibility (because of inevitable slipping of a belt on pulleys) obtaining exact, invariable values of transfer numbers (excepting zubchatozemny transfers);
- low wear resistance and endurance of belts (low durability of 1000 ... 5000 hours);
- gradual pulling of belts, their fragility;
- need of application for transfers of the special devices intended for a belt tension, or his alterations in process of a pulling in use of transfer;

- need of protection of belts against hit on them mineral oils, gasoline, alkalis, etc.;
- the possibility of electrization of belts excluding use of belt drives in explosive environments;
- the considerable operational costs connected with rather big losses on friction (costs of the electric power) and low (1000 ... 5000 h) the durability of belts causing additional costs of their replacement in use of transfer.

Due to noted features belt drives generally apply to transfer rotary motion between the parallel shaft, located at rather long distance from each other at low values of the transferred power to a high-speed step drive, as in this case their major shortcoming exert the smallest impact on dimensions and mass of the drive in general. Therefore, installation of the leading pulley on an electric motor shaft is most characteristic of belt drives.[17]

Two saddles were installed, one on top of the vertical rack, the second one is located under the driven pulley. This does not influence on the work of the mechanism, but it as a solution to avoid sag, which can happen during the work of the cocktail machine.

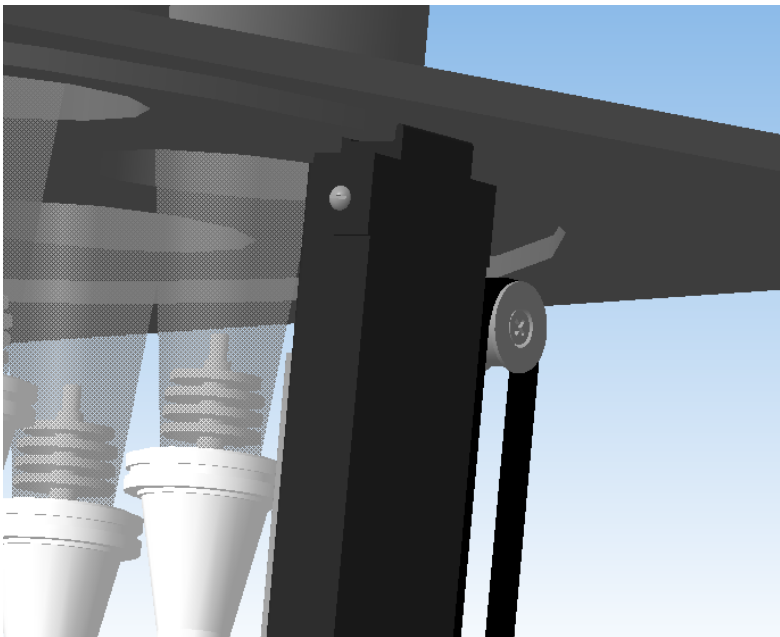

Figure 3.13 Saddle

3.6.2 Stepper motor

For ensuring the movement of the platform stepper motor was chosen, as it provides high precision and accuracy. It also fits well for tuning with Arduino.

Stepper motors are versions of brushless engines of a direct current. They are applied in peripheral devices of the computer equipment, robotics, industrial equipment, etc. This type of

engines should not be mixed together with multiphase brushless engines. Their main difference is that the turn of the engine is made on some corner, a step when giving impulse of tension on engine windings, from here and the name of engines.

The stepping motor allows to realize positioning of a rotor to a fraction of degree, that is absolutely unattainable for other types of engines. Rotational speed is defined only by the frequency of following of control pulses. These engines, unlike collector engines, are almost eternal, which has defined their field of activity – devices of exact positioning.[18]

Advantages:

The most significant advantages of the stepping motor:

- 1) Stability. Works in case of different loadings;
- 2) Doesn't require back coupling. Feedback is not required, as the engine has the fixed angle of rotation. Other types of electric motors demand existence of the sensor of a rotation angle.
- 3) Rather low cost for the organization of systems with controlled relocation; The cost of servo-drivers which can be used as an alternative to step engines is one and a half-two times higher with identical technical characteristics.
- 4) The standardized sizes of the engine and a turning angle; Step engines are standardized by national association of producers of electric equipment (NEMA) by the landing sizes and the size of a flange: NEMA 17, NEMA 23, NEMA 34, ... — the size of a flange is 42 mm, 57 mm, 86 mm, 110 mm respectively.
- 5) Reliability. The engine stops in case of failure. The engine stop, in case of failure, prevents causing damage to other blocks, elements and mechanisms.
- 6) Long period of operation; A service life of the step engine actually is defined by durability of bearings and other mechanical elements.
- 7) An excellent torsional moment on low turns;
- 8) Excellent recurrence when positioning;
- 9) The stepping motor can not burn down in case of the loading exceeding the maximum turning couple of the engine. (In case of such loading the engine will just pass steps);

It is worth carrying to disadvantages:

- 1) The torsional moment sharply decreases in case of increase in rotating speed (the torsional moment is inversely proportional speeds);
- 2) It is inclined to a resonance. Elimination of resonant processes requires microstep;
- 3) There is no back coupling for monitoring of steps;
- 4) High heating of the engine in the course of operation;
- 5) Noisy on average and high rates;

The most dangerous of these shortcomings is the resonance phenomenon which can lead to the pass of steps, but this will be avoided during the selection of the stepper motor.

3.7 Vertical moving rack

The main purpose of the vertical rack is pushing on the chosen dispenser, after the platform has moved to the correct position. The belt drive is a good solution for pushing function, because of several points:

- pushing mechanism requires high precision
- if the mistake in motor occurs, then a belt will just slip and that will avoid fatal crashes
- belt drives are cheap

There is no need in a high power in this drive, as the force, needed for pushing at the dispenser is very low.

Pusher has three positions:

- initial position, between dispensers and funnel, to let the platform move to the needed dispenser;
- position, when a dispenser, located on an external side is being pushed;
- position, when a dispenser, located on an internal side is being pushed;

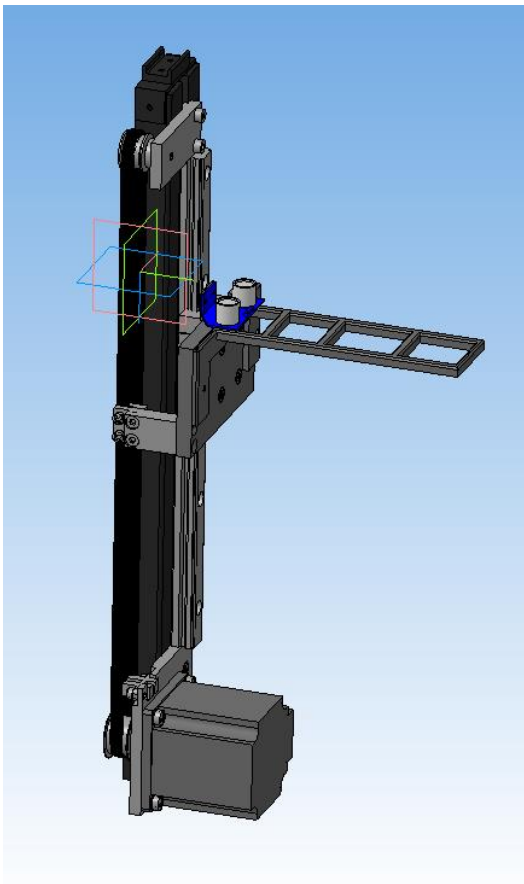

Figure 3.14 Vertical rack

The pusher is located between the funnel and dispensers and moves roundabout with a vertical rack, until the platform reaches its destination. The material of the pusher is duralumin, because this part needs extra rigidity and hardness. Square holes apply for pushing on the rods of the dispensers, located on external and internal sides of the circle. This detail is attached to the carriage, which is being moved by the belt drive and stepper motor.

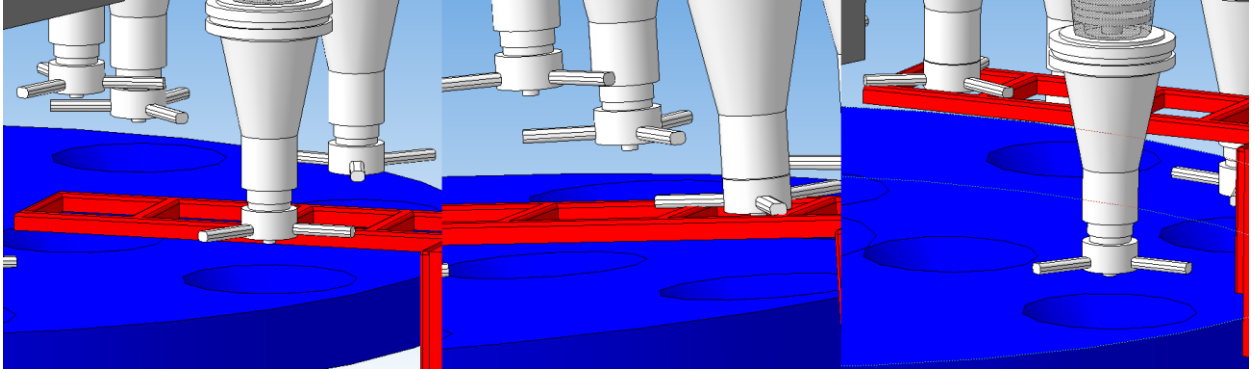

Figure 3.15 Positions of the pusher: initial-push on the external circle-push on the internal circle

Internal flasks and dispenser are located higher, than external to avoid mistakes or crashes while moving or pushing. An ultrasonic dispenser is attached to the pusher, for moving to initial position.

3.8 Arduino

Arduino- cheap, reliable and perspective way of control, is used for operating the step motors of the cocktail machine. Arduino works practically with any kind of sensors or chips. Raspberry Pi, for example, is not so flexible, for reading analog sensors additional hardware is required.

Arduino is an open source, computer hardware and software company, project, and user community that designs and manufactures microcontroller kits for building digital devices and interactive objects that can sense and control objects in the physical world. The project's products are distributed as open-source hardware and software, which are licensed under the GNU Lesser General Public License (LGPL),[1] or the GNU General Public License (GPL),[1] permitting the manufacture of Arduino boards and software distribution by anyone. Arduino boards are available commercially in preassembled form, or as do-it-yourself kits.[19]

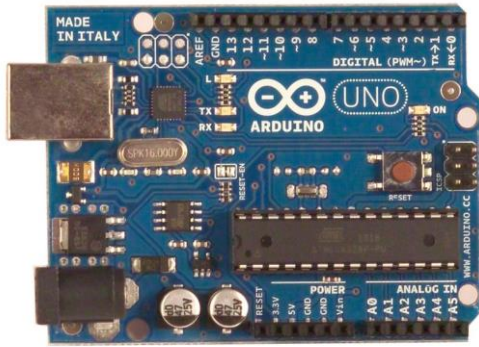

Figure 3.16 Arduino Uno [19]

Arduino/Genuino Uno is a microcontroller board based on the ATmega328P (datasheet). It has 14 digital input/output pins (of which 6 can be used as PWM outputs), 6 analog inputs, a 16 MHz quartz crystal, a USB connection, a power jack, an ICSP header and a reset button. It contains everything needed to support the microcontroller; simply connect it to a computer with a USB cable or power it with a AC-to-DC adapter or battery to get started.. You can tinker with your UNO without worrying too much about doing something wrong, worst case scenario you can replace the chip for a few dollars and start over again.[19]

"Uno" means one in Italian and was chosen to mark the release of Arduino Software (IDE) 1.0. The Uno board and version 1.0 of Arduino Software (IDE) were the reference versions of Arduino, now evolved to newer releases. The Uno board is the first in a series of USB Arduino boards, and the reference model for the Arduino platform; for an extensive list of current, past or outdated boards see the Arduino index of boards.

Arduino Uno fits perfectly to control the work of stepper motors and sensors, internet is full of different codes, libraries and instructions, all the required details for this a given below:

- Insulated copper wire
- wire cutters
- current regulator
- transistor
- H-bridge
- motor shield

An H-Bridge is a circuit comprised of 4 switches that can safely drive a DC motor or stepper motor. These switches can be relays or (most commonly) transistors. The transistor is a solid state switch that can be closed by sending a small current (signal) to one of its pins. Unlike a single transistor,

which only allow you to control the speed of a motor, H-bridges allow you to control the direction in which the motor spins. It does this by opening different switches (the transistors) to allow the current to flow in different directions and thus changing the polarity on the motor. [20]

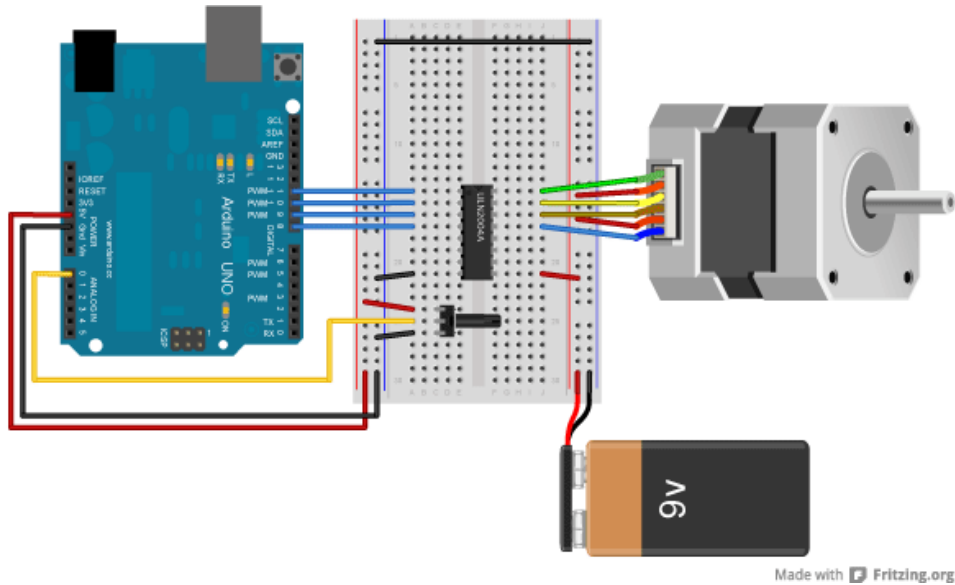

Figure 3.17 Arduino and the stepper [20]

3.9 Liquid measuring

As the upper platen is made from the polycarbonate, which is transparent, it possible to measure the rest of beverages in flasks visually. But this is not enough for such amount of spirits, so, to avoid using any sensors to reduce the price of the machine, a solution was found.

Dispensers dose an exact portion of beverage, and portion depends only on the capacity of the dispensers. Each time, when a new flask is added to the cocktail machine, user must add information to the system with the help of the touch screen. After the machine gets information, which kind of drink with witch capacity of dispenser is added to the specified hole, it starts to count number of pushes, done on each dispenser. When there are only couple of doses in a section, or their amount is not enough for mixing needed cocktail, a warning will be displayed on a screen. The machine will not start the work, if there will be a lack of spirits. Number of doses varies, depending on the capacity of the dispenser. A table of doses is given below.

Table 1 Number of doses, depending on dispensers capacity

Capacity of dispenser	Number of doses
15 ml	50
25 ml	30
30 ml	25
35 ml	21
45 ml	16
50 ml	15

Capacity of a dispenser is chosen by the kind of a drink and wishes and preferences of user. For example for non-alcohol liquids, like juice or soda, dispensers of high capacity should be used, while syrups like grenadine should be equipped with low-capacity dispensers.

3.10 Sensors

The ultrasonic range finder defines distance to objects in the same way as it is done by dolphins or bats. It generates sound pulses at a frequency of 40 kHz and listens to an echo. It is possible to determine distance to an object by propagation time of a sound wave.[21]



Figure 3.18 The ultrasonic range finder [21]

Unlike infrared range finders, indications of an ultrasonic range finder aren't influenced by flares from the sun or color of an object. Even the transparent surface will be for it a hindrance. But there can be difficulties with range sensing to fluffy or very thin objects.[21]

Characteristics

Voltage: 5 V

Consumption in a silence mode: 2 mA

Consumption during the work: 15 mA

Range of distances: 2–400 cm

Effective angle of observation: 15 °

Working angle of observation: 30 °

For positioning of the bigger platform reed switch is used, and a magnet is attached to the bottom platen. The reed switch — the electromechanical switch changing a status of the connected electrical circuit in case of influence of a magnetic field from a permanent magnet or an external electromagnet, for example, of the solenoid.

It is constructive in the reed switch there are elastic ferromagnetic contacts which are soldered in in a hermetic glass flask. These contacts combine functions of the current distributor, a magnetic conductor and a spring.

In case of increase in an outside magnetic field over threshold elastic contacts of the reed switch "stick together", shorting an electrical circuit. In case of removal of an outside margin due to elasticity of contacts there is a breaking of a circuit.[22]



Figure 3.19 Reed switch [22]

In comparison with the normal switching contacts reed switches have nearly 100 times big reliability in comparison with normal open contacts. This reliability is caused by more high resistance of insulation, and bigger breakdown strength: puncture voltage at some types of sealed-contacts reaches several tens kilovolts.

Indisputable advantage of reed switches is their high-speed performance: at some models of reed switches frequency of switching reaches 1000 Hz. Service life of some reed switches reaches 4 - 5 billion activations that is much higher than a similar index for the normal not protected contacts.

Also it is necessary to carry an easy method of coordination with loading and also operation of reed switches without application of sources of electrical energy to advantages of sealed-contacts.[22]

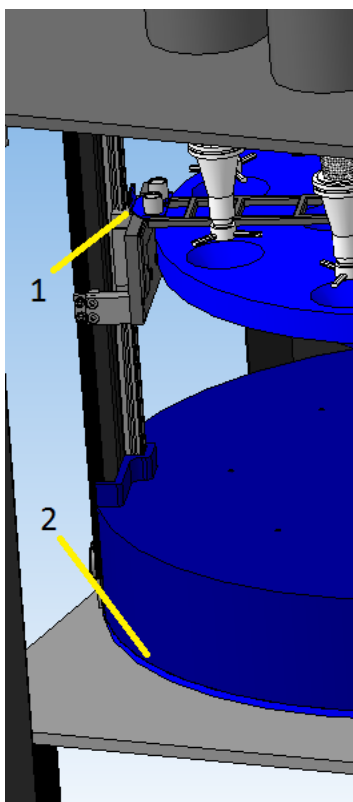

Figure 3.20 Location of sensors

1-Ultrasonic range finder on the moving pulley; 2-Reed switch under the platform

3.11 Basic principle of work

Cocktail machine has two main working modes-loading mode and mixing.

Loading mode is switched by the user with the help of touch screen, when there is a need to make any changes in beverage position and amount. This mode consists of three different variants of loadings:

1. 'Refilling'. This mode is switched on, if there is a need to change empty flasks to the new ones. User chooses the hole of the flask to change on the touch screen, and sets the amount of spirit inside the bottle, if it is not full.
2. 'Thematic'. In this mode cocktails are sorted in different themes, like 'New Year', 'Beach party', and so on. User chooses the theme, that is needed, and the cocktail machine specifies, which spirits with which dispensers should be placed in a certain hole.
3. 'Everything we got'. According to the name, in this mode user simply adds in the cocktail machine every available drinks. After choosing the drink, machine gives a recommendation, which dispenser is suitable for this spirit. Finally, all cocktails, which are possible to mix, will be listed on a screen.

The basic algorithm of mixing mode is given below.

Block 'Turning to nearest appropriate position' means, that the platform of the machine is turning at the angle, needed to reach the position of the dispenser, which should be pushed.

Block 'Waiting, according to the capacity' means, that the dispenser should stay pushed for a several time, and this time depends directly on its capacity.

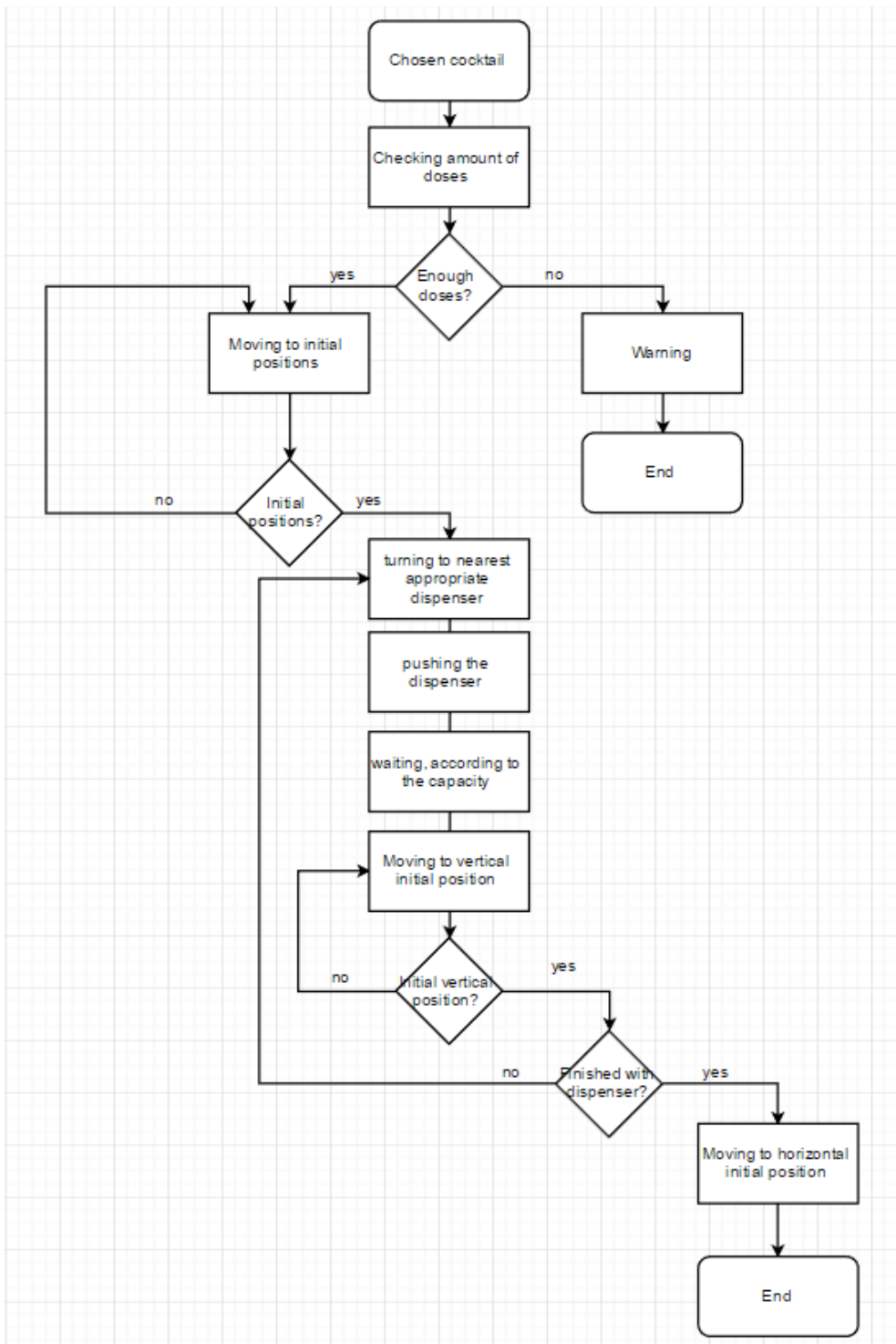

Figure 3.21 Algorithm of work

CHAPTER 4

4.1 Stepper

There are three main types of stepping motors:

- engines with variable magnetic resistance;
- engines with permanent magnets;
- hybrid engines;

In the stepper motor with variable magnetic resistance the turning couple is created by magnetic fluxes of the stator and a rotor which are appropriately oriented from each other. This type of the engine is not sensitive to the direction of current in windings. The turning couple is proportional to value of a magnetic field, which, in turn, is proportional to current in a winding and to quantity of rounds. Thus, the moment developed by the engine depends only on parameters of windings.

Engines with permanent magnets consist of the stator which has windings, and the rotor containing permanent magnets. The alternating poles of a rotor have the rectilinear form and are located parallel to an engine axis. Thanks to magnetization of a rotor in such engines the bigger magnetic flux and, as a result, the bigger moment, than at engines with variable magnetic resistance is provided.

Hybrid engines are more expensive, than engines with permanent magnets, but they provide smaller value of a step, the bigger moment and high speed. Hybrid engines combine the best lines of engines with variable magnetic resistance and engines with permanent magnets.

Except the design features connected to execution of a rotor, engines differ also in execution of windings of the stator. Depending on a configuration of windings engines are divided into unipolar and bipolar and have three options of execution of a configuration of windings. In the unipolar engine one winding in each phase, with leadout from the middle of each winding is included. It allows to change the direction of the magnetic field created by a winding, switching of its halves. At the same time the diagram of the driver significantly becomes simpler: it represents four simple keys. As a rule, the unipolar engine has six outputs, but average outputs of windings can be integrated in the engine therefore such engine can have also five outputs.

The bipolar engine has two windings which join serially in each phase. The engine of this kind requires more difficult driver of bridge type. The unipolar engine with two windings and branches can be used in the bipolar mode if branches are not connected.

It is easy to notice that at bipolar management the moment developed by the engine will be higher. In the bipolar engine all windings at the same time work, and the prize in the moment makes about 40%. [18]

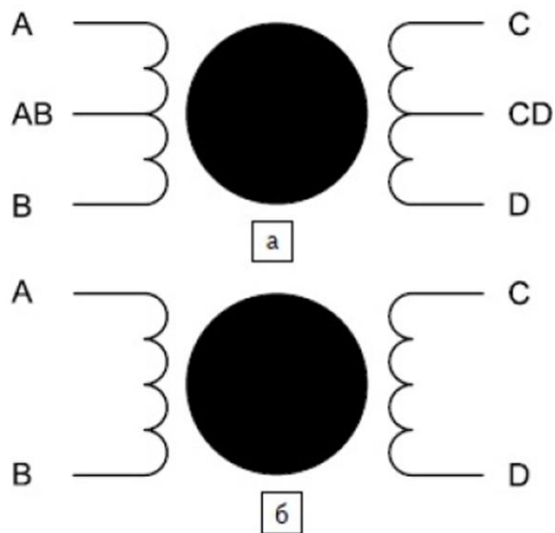

Figure 4.1 Bipolar stepper [18]

4.2 Materials of driving belts

General requirements to materials of driving belts: wear resistance and durability at cyclic loadings; high coefficient of friction with pulleys; small module of elasticity and flexural rigidity.

The high-quality leather and synthetic materials (rubber, polymeric (kapron, SKN-40 rubber, latex) or a metal cord meet these conditions. Rubberized fabric belts (State standard specifications 101-54), layered cut belts with rubber layers, layer-by-layer and wrapped up belts are applied. In crude rooms and hostile environment belts with rubber laying are applied.

Pulleys are produced from cast iron, steel, aluminum alloys, textolites.

For reduction of slipping of a belt for production of pulleys of belt transfer it is desirable to choose textolite. In comparison with other materials in this case transfer will have a big reliability of work without pro-slipping.[17]

Leather belts are produced from leather of animals (skin is subjected to a special tanning). These belts possess high tractive ability, elasticity and wear resistance, allow smaller diameters of pulleys, well work in case of alternating and shock loads. However because of deficiency and high cost now they are applied seldom, only to especially responsible constructions. Leather belts aren't recommended for an exploitation in the environments with high humidity, with vapors of acids and alkalis.

Basis of a rubberized belt — the strong cord pro-vulcanized technical cotton(belting) in 2-9 layers connected among themselves by the vulcanized rubber. The fabric having bigger elastic modulus, than rubber transfers the main part of loading. Rubber raises friction coefficient, ensures functioning of a belt as whole and protects fabric from damages and abrasion during a transmission

operating time. Owing to durability, elasticity, small sensitivity to moisture and oscillations of temperature, rubberized belts are widespread. A lack of these belts is the destroying impact on them of mineral oils, gasoline, alkalis. Rubberized belts of all types produce as without rubber lining (for reference conditions of operation), and with plates (for operation in the raw locations, and also in the environment saturated with vapors of acids and alkalis).

Textile belts (cotton and woolen) are made in several layers of woolen and cotton threads. Become impregnated with structure from drying oil, powder chalk and iron minium. They are less sensitive to the increased temperature, humidity, vapors of acids and alkalis, as defines their scope. Have elasticity, well work at uneven and shock loading. The most admissible speed is $V = 30$ m/s, strength on a gap, $\sigma_B = 30$ MPas. Suitable for work in the atmosphere dusty, saturated with vapors of alkalis, gasoline, at sharp fluctuations of loading, but traction ability their rather low.

Cotton belts produce on weaving looms from cotton yarn in several intertwining layers (four-eight) with the subsequent impregnation by ozokerite and bitumen. Cotton belts have smaller cost, than rubberized.

Woolen belts produce from the wool yarn bound and stitched by the cotton yarn impregnated with structure from drying oil, chalk and iron minium. Load ability of these belts is higher, than cotton. Find application in chemical industry.[17]

Polyamide belts make of the artificial threads received by way of a cold broach from polyamide pitch or a tape. Belts from this material are suitable for transfers with small interaxal distance and for high-speed transfers ($V = 70$ m/s). The nylon flat belt covered with rubber mix has shown good results of work at ($V = 100$ m/s). Polyamide belts are silent and have insignificant wear. Two-layer belts from nylon and chromic skin have very big durability and elasticity. Chromic: skin during the work on metal has high coefficient of friction. Such belts transfer three times big power to belt width unit, than leather or cotton.

Film belts from kapron fabric or serge with a frictional covering (film) are widely adopted. High static and fatigue durability of synthetic materials has given the chance to reduce belt thickness (= 0,4 1,2 mm), his mass and action of centrifugal forces. It has allowed to increase belt speed from 25 30 (for usual belts) to 75 150 m/s and at the same time to provide big smoothness of operation that is especially important for modern mechanical engineering.

Synthetic belts in view of their increased durability and durability, and also an opportunity to provide rather high value of coefficient of friction are the most perspective of fabric belts. These belts have the small weight and rather high coefficient of friction with a pulley.

However still they are made in the limited range of the sizes that constrains a possibility of their broader application.[17]

4.3 Calculation of the parameters of the vertical rack

4.3.1 Choice of the stepper for the vertical rack

Initial data:

$m = 0.9 \text{ kg}$ mass of the moved freight

$V = 1.2 \text{ m/s}$ speed of movement of freight

$H = \frac{360}{\varphi} = \frac{360}{0.9} = 400$ quantity of steps on one turn (the half step mode)

$R = 0.012 \text{ m}$ pulley radius

Kinetic energy of system

$$E = \frac{1}{2}(m \cdot V^2 + J \cdot \omega^2) = \frac{1}{2} \cdot J_1 \cdot \omega^2, \quad (4.1)$$

where J-moment of inertia of a pulley

$$J = \frac{1}{2} \cdot m \cdot (r_1^2 + r_2^2) = 0.5 \cdot 0.03 \cdot (0.0035^2 + 0.012^2) = 7 \cdot 10^{-6} \text{ kg} \cdot \text{m}^2 \quad (4.2)$$

Derivative of kinetic energy on time

$$\frac{dE}{dt} = J_{np} \cdot \omega \cdot \varepsilon \quad (4.3)$$

The sum of capacities of all external forces in system

$$\sum P = M \cdot \omega \quad (4.4)$$

Derivative of kinetic energy on time it is equal to the sum of capacities of external forces:

$$J_{np} \cdot \omega \cdot \varepsilon = M \cdot \omega \quad (4.5)$$

We receive a torsional moment:

$$M = J_{np} \cdot \varepsilon = (m \cdot R^2 + J) \cdot \varepsilon \quad (4.6)$$

Ratio between angular speed ω and frequency of working off of steps:

$$\omega = \frac{H \cdot v}{2 \cdot \pi} \quad (4.7)$$

Acceleration of a rotor of the stepping motor:

$$\varepsilon = \omega \cdot v = \frac{H \cdot v^2}{2 \cdot \pi} = \frac{2 \cdot \pi \cdot V^2}{H \cdot R^2} \quad (4.8)$$

Final torsional moment of a pulley:

$$M = \frac{2 \cdot \pi \cdot V^2}{H \cdot R^2} \cdot (m \cdot R^2 + J) \quad (4.9)$$

$$M = \frac{2 \cdot 3.14 \cdot 1.2^2}{400 \cdot 0.012^2} \cdot (0.9 \cdot 0.012^2 + 7 \cdot 10^{-6}) = 0.028 \text{ N} \cdot \text{m} \quad [24] \quad (4.10)$$

We suit the bipolar stepping motor 17HS4401 with the following characteristics:



Figure 4.2 Chosen stepper [25]

Spindle length 22 mm

Type: Hybrid

Inductance of a phase: 1 mGn

Number of phases: 2

The consumed current: 0.95 A

Resistance: 2.8 Om

Torque: 0.43 kg*cm

Moment of inertia of a rotor: 0.9g*cm²

Step: 1.8°

Weight: 0,11 kg

FL28STH45-0956A

24 VDC, 0.95 A/phase, half step

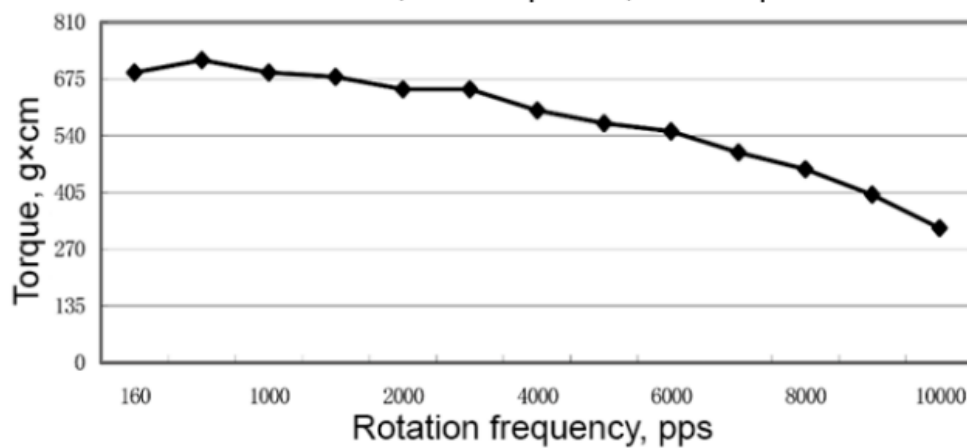

Figure 4.3 Mechanical characteristic of a stepper

On the graph it is visible that in case of rotating speed 1400 turnovers/min, there is a torsional moment of 0,0559 Nanometers which suits us.

Calculation of resonance frequency of the engine:

$$F_0 = \frac{\sqrt{(N \cdot T_H / (J_R + J_L))}}{4 \cdot \pi} , \quad (4.11)$$

where F_0 – resonance frequency,

N – number of complete steps on a turn,

T_H – the holding moment for the used method of control and current of phases,

J_R – a rotor inertia moment,

J_L – a loading inertia moment.

A loading inertia moment is estimated. As loading moves bodily, from the law of kinetic energy:

$$\frac{m \cdot V^2}{2} = J \cdot \frac{\omega_d^2}{2} , \quad (4.12)$$

where m - loading mass,

V - speed of movement of loading (speed of the belt drive),

J -moment of inertia of loading,

ω_d - angular speed of the engine

Thus the moment of inertia of loading is defined:

$$J = m * \left(\frac{V}{\omega_d}\right)^2 = 0.9 * \left(\frac{1.2}{146}\right)^2 = 6 * 10^{-5} \text{ kg} * \text{m}^2 \quad (4.13)$$

Then resonant frequency of the engine:

$$F_0 \sqrt{\frac{400 * 0.36}{\frac{6 * 10^{-5} + 0.9 * 10^{-6}}{4 * 3.14}}} = 407 \text{ s}^{-1} = 3890 \text{ tur/min} \quad (4.14)$$

The resonance frequency is far from operating frequency of 1400 RPM and there will not be a resonance.

4.3.2 Belt parameters

Initial Data:

$P = M * n * 0.1 = 0.0559 * 1400 * 0.1 = 7.8 \text{ W}$ -power on the drive pulley;

$V = 1.2 \text{ m/s}$ Speed of moving;

$a = 325 \text{ mm}$ Interaxal distance.

Belt module

$$m = 3.5 * \sqrt[3]{\frac{1000 * 0.0078}{1400}} = 0,6195 \quad (4.15)$$

Then $m=1\text{mm}$

Belt tooth pitch:

$$p = \pi * m = 3.14 * 1 = 3.14 \text{ mm} \quad (4.16)$$

Number of teeth leading/slave pulleys according to $m=1 \text{ mm}$: $z=16$

Diameter of dividing circle of pulleys:

$$d = z * m = 16 * 1 = 16 \text{ mm} \quad (4.17)$$

Belt length:

$$l' = 2 * a + \pi * \frac{(d_2 + d_1)}{2} + \frac{(d_2 - d_1)^2}{4 * a} = 2 * 325 + 3.14 * \frac{16 + 16}{2} = 700,24 \text{ mm} \quad (4.18)$$

Belt teeth number:

$$z_p = \frac{l'}{\pi * m} = \frac{700,24}{3.14 * 1} = 223,0063 \quad (4.19)$$

Then $z_p = 300$

Real belt length:

$$l = z_p * \pi * m = 223 * 3.14 * 1 = 690.8 \text{ mm} \quad (4.20)$$

Interaxal distance for belt length 690 mm:

$$\begin{aligned} a &= 0.25 * (l - 0.5 * \pi * (d_1 + d_2)) + \sqrt{(l - 0.5 * \pi * (d_1 + d_2))^2 - 2 * (d_2 - d_1)^2} = \\ &= 0.25 * (690 - 0.5 * 3.14 * (16 + 16)) + \sqrt{(690 - 0.5 * 3.14 * (16 + 16))^2 - 2 * (16 - 16)^2} = 320.28 \text{ mm} \end{aligned} \quad (4.21)$$

Number of belt teeth within the coverage angle with the drive pulley:

$$z_0 = z * \frac{180^\circ - 57.3^\circ * \frac{d_2 - d_1}{a}}{360^\circ} = 16 * \frac{180^\circ - 57.3^\circ * \frac{16 - 16}{320.28}}{360^\circ} = 8 \quad (4.22)$$

Rotation frequency of belt pulley:

$$\frac{60 * 1000 * v}{\pi * d} = \frac{60 * 1000 * 1.2}{3.14 * 16} = 1400 \text{ turnovers/min} \quad (4.23)$$

Estimated circumferential force:

$$F_{tp} = \frac{P_{tp}}{v} = \frac{7.8}{1.2} = 6.5 \text{ N} \quad (4.24)$$

Nominal permissible specific circumferential force

$w_0 = 2.5 \text{ N/m}$

Linear density of 1m belt with width 1mm

$q = 0.002 \text{ kg}/(\text{m} * \text{mm})$

Estimated permissible circumferential force:

$$[w] = w - q * v^2 = 2.5 - 0.002 * 1.2^2 = 2.5 \text{ N/mm} \quad (4.25)$$

Estimated belt width:

$$b' = \frac{F_{tp}}{[w]} = \frac{6.5}{2.5} = 2.6 \text{ mm} \quad (4.26)$$

Real belt width considering $K = 0.7$

$$b = \frac{b'}{K} = 3.7 \text{ mm} \quad (4.27)$$

then $b=4 \text{ mm}$ [23]

4.3.3 Calculation of wear resistance

Tooth height $h=0,8 \text{ mm}$

Allowable pressure on the belt teeth $n=1700 \text{ turnovers/min}$

$$[p]_z = 0.8 \text{ MPA}$$

Pressure on the belt teeth:

$$p = \frac{F_{tp} * \varphi}{z_0 * b * h} = \frac{6.5 * 2}{8 * 4 * 0.8} = 0.507 \text{ MPa}, \quad (4.28)$$

where $\varphi = 2$ is a load concentration coefficient

$$p \leq [p]_z$$

Durability condition fulfilled

Initial belt tension:

$$F_0 = 0.1 * F_{tp} + q * v^2 * b = 0.1 * 6.5 + 0.002 * 1.2^2 * 4 = 0.77 \text{ N} \quad (4.29)$$

The force, acting on the shafts:

$$F_v = 1.5 * F_{tp} = 1.5 * 6.5 = 9.75 \text{ N} \quad [23] \quad (4.30)$$

4.4 Calculation of the parameters of the platform

Linear belt speed (4.31)

$$v = \frac{\pi \cdot d_{pM} \cdot n_1}{60 \ 000} = \frac{\pi \cdot d_{p6} \cdot n_2}{60 \ 000} \text{ m/s}$$

where $d_{p,6}$ and $d_{p,M}$ - settlement diameters of bigger and smaller pulleys, mm;

n_1 и n_2 rotation frequency of bigger and smaller pulleys, min^{-1}

Transferred power, $N = N_0 * k_1 * k_2 * z$;

where N_0 — power, kW , transferred by one belt;

k_1 — coefficient of the grasp angle;

Table 4.1 Correction factors

Grasp corner α°	180	170	160	150	140	130	120	110	100	90	80	70
Correction factor	1,00	0,98	0,95	0,92	0,89	0,86	0,83	0,78	0,74	0,68	0,62	0,56

Grasp angle by a belt of a pulley during the work on two pulleys is calculated on a formula

$$\alpha = 180^\circ - 60^\circ \cdot \left(\frac{d_{p.b} \cdot d_{p.m}}{l} \right)$$

It is recommended to accept a pulley grasp angle not less than 120°

k_2 —coefficient, considering character of loading and an operating mode;

z — number of belts,

Drive power during the work on two pulleys pays off for a pulley with smaller settlement diameter, and during the work on several pulleys - the leading pulley. The possibility of transfer of necessary power must be verified in addition on the conducted pulleys having a smaller angle of a grasp or smaller diameter in comparison with the leading pulley.

Interaxial distance at two pulleys $l = k \cdot d_{p.b}$,

where $d_{p.b}$ - the settlement diameter of a big pulley;

$k = l / d_{p.b}$ —depending on transfer number.

Table 4.2 Transfer numbers

Transfer number	1	2	3	4	5	6 and more
$k = l / d_{p.b}$	1,5	1,2	1	0,95	0,9	0,85

The smallest admissible interaxial distance $L_{p.min} = 0,7 \cdot (d_{p.b} + d_{p.m})$;

where $d_{p.m} = d_{p.b} / i$ — the settlement diameter of a smaller pulley;

i — transfer number

The greatest interaxial distance $L_{p.max} = 2(d_{p.b} + d_{p.m})$;

On the chosen approximate interaxial distance $L_{p.min} \leq L_p \leq L_{p.max}$

Belt length $L = 2L_p + W + y/L_p$

where

$$W = \left(\frac{d_{p.b} + d_{p.m}}{2} \right) \cdot \pi \tag{4.32}$$

and

$$y = \left(\frac{d_{p,b} - d_{p,m}}{2} \right)^2 \quad (4.33)$$

The calculated settlement length is rounded to the state standard specification next value.

After that final interaxal distance is defined

$$l = 0,25 \cdot (L - W) + \sqrt{(L - W)^2 - 8 \cdot y} \quad (4.34)$$

For compensation of possible deviations of length of a belt from face value, when designing transfer, adjustment of intercenter distance of pulleys towards reduction by 2% with a length of belt of L up to 2 m has to be provided and for 1% with a length of belt over 2 m and towards increase by 5,5% of L.

Transfer number i	9
Estimated diameter of a smaller pulley $d_{p,m}$	15 mm
Estimated diameter of a bigger pulley $d_{p,b}$	135 mm
Rotating speed of smaller n_1	750 min^{-1}
Rotating speed of bigger n_2	83.3 min^{-1}
The line speed of a belt v	0.6 m/s
Interaxal distance in case of two pulleys L_p	114.8 mm
The smallest admissible interaxal distance $L_{p,min}$	82.5 mm
The greatest interaxal distance $L_{p,max}$	300 mm
The smallest pulley wrapping angle	92.7°
The greatest pulley wrapping angle	156°

The transferred power and settlement length of a belt are determined.

The transferred power, $N = N_0 \cdot k_1 \cdot k_2 \cdot z$

N_0 — power, kW, transferred by one belt

k_1 — the coefficient depending on a grasp angle;

Table 4.3 Correction coefficients

Angle of a grasp α°	180	170	160	150	140	130	120	110	100	90	80	70
Correction coefficient	1,00	0,98	0,95	0,92	0,89	0,86	0,83	0,78	0,74	0,68	0,62	0,56

Grasp angle α of a belt of a pulley during the work on two pulleys is calculated on formula

$$\alpha = 180^\circ - 60^\circ \cdot \left(\frac{d_{p6} \cdot d_{pm}}{1} \right)$$

It is recommended to accept a pulley grasp angle not less than 120°

k_2 — coefficient considering character of loading and an operating mode

z — number of belts,

Settlement length of a belt $L = 2L_p + W + y/L_p$ On the chosen approximate interaxal distance $L_{p,min} \leq$

$L_p \leq L_{p,max}$

$$W = \left(\frac{d_{p,b} + d_{p,m}}{2} \right) \cdot \pi \quad y = \left(\frac{d_{p,b} - d_{p,m}}{2} \right)^2 \quad (4.35)$$

Transfer number i	9
Estimated diameter of a smaller pulley $d_{p,m}$	15 mm
Estimated diameter of a bigger pulley $d_{p,6}$	135 mm
Rotating speed of a smaller pulley n_1	750 min^{-1}
Rotating speed of a bigger pulley n_2	83.3 min^{-1}
The linear speed of a belt v	0.6 m/s
Interaxal distance L_p	251 mm
Belt section	Z(0)
Pulley wrapping angle	151.3°
The transferred power	0.846 kW
Computational length of a belt	752 mm

For this belt drive a stepper FL42STH47-1684MA is chosen.

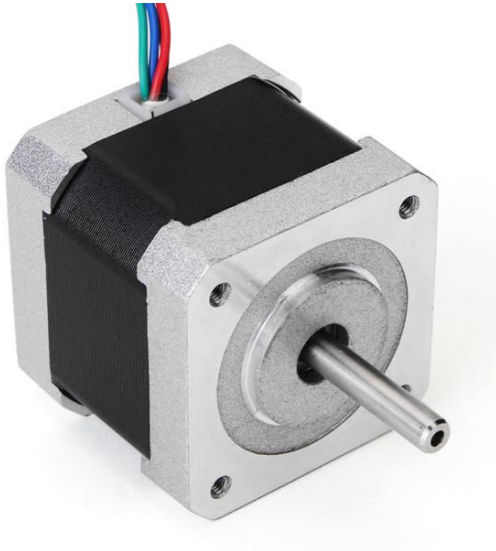

Figure 4.4 Second chosen stepper

The size and torque of this stepper fit us very well.

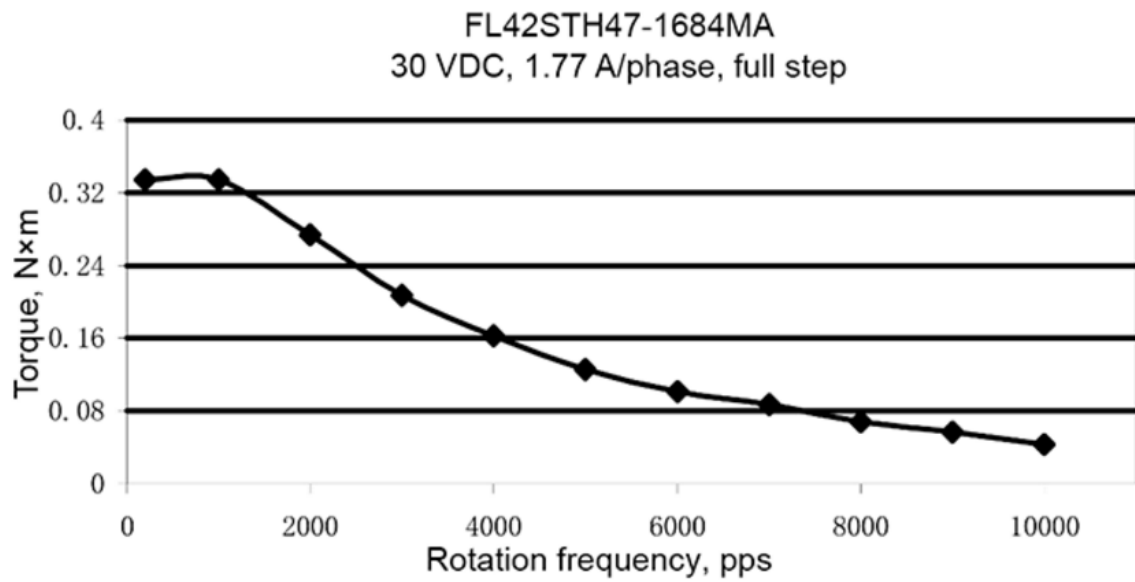

Figure 4.5 Mechanical characteristic of second stepper

4.5 Calculation of the load on the vertical rack

The calculation is made in such way, when the cocktail machine is fully loaded with spirits. The goal is to find load on each vertical rack considering the weight of bottles, beverages and all the details. It is also necessary to find the minimal square of the rack.

$$Q_1 = 245 \frac{N}{m^2},$$

$$Q_2 = 98 \frac{N}{m^2},$$

$$[G] = 9807 \frac{N}{cm^2}$$

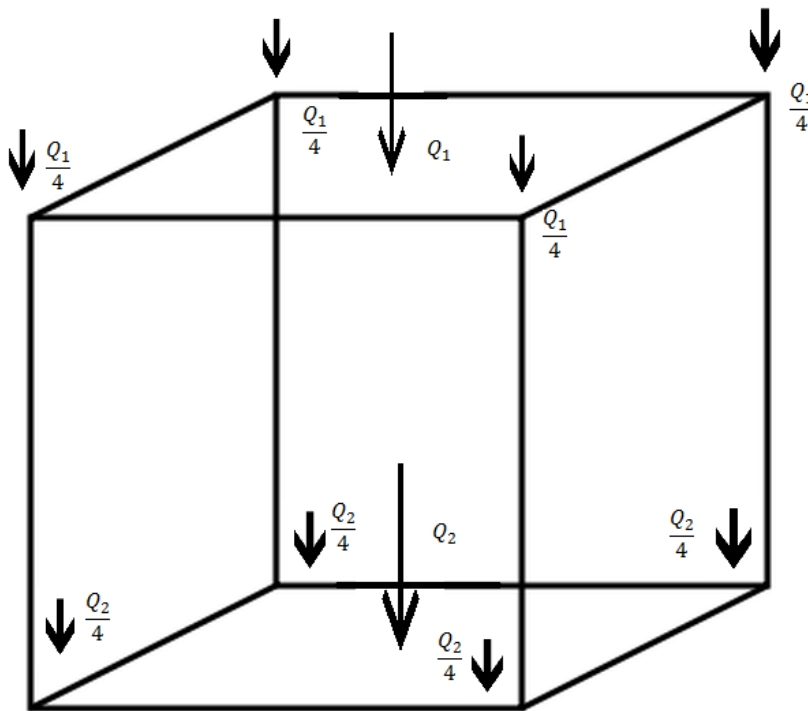

Figure 4.6 Load on the case

1. Load on each vertical rack is being calculated.

$$q_1 = \frac{Q_1}{4} = \frac{245}{4} = 61.25 \frac{N}{m^2} \quad (4.36)$$

$$q_2 = \frac{Q_2}{4} = \frac{98}{4} = 24.5 \frac{N}{m^2} \quad (4.37)$$

2. Load on the rack is being calculated on each circuit.

$$0 \leq z_1 \leq 0.53 \text{ m}$$

$$N_1 = -q_1 = -61.25 \frac{N}{m^2}$$

$$0.53 \leq z_2 \leq 0.6 \text{ m}$$

$$N_2 = -q_1 - q_2 = -61.25 - 24.5 = -85.75 \frac{N}{m^2}$$

$$85.75 \frac{N}{m^2} = 8.75 \text{ kg/m}^2$$

3. Second circuit is the most dangerous. The minimal square of the vertical rack is being calculated.

$$A \geq \frac{N}{[G]} = \frac{8.75}{1000} = 0.00875 \text{ cm}^2 \quad (4.38)$$

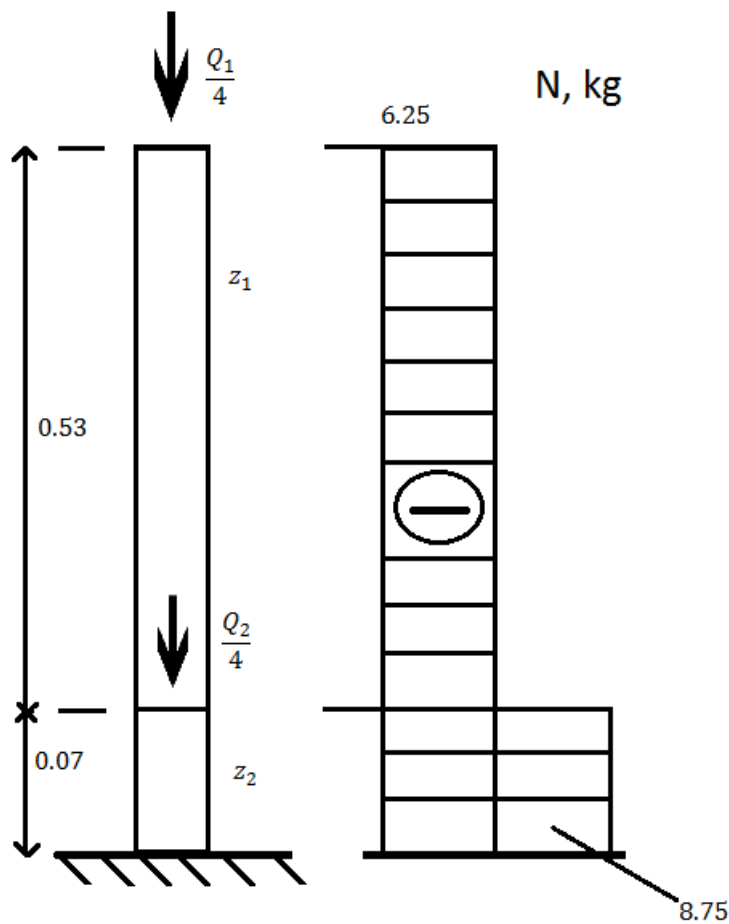

Figure 4.7 Diagram

4.6 Economic calculation

The price of the device in the conditions of future production (serial, mass, individual) has to be determined proceeding from its standard prime cost and profitability of 20-25%.

A table, containing prices of all components of the cocktail machine is given below.

Table 4.4 Prices

Name	Price, €
Dispenser	5*12
Flask	2.5*12
Tecamid 66	4.2
Polycarbonate	5
Duralumin	17
Belts	9
Sensors	7
Arduino	6
17HS4401	15
F142STH47	24
Other	20
Tablet	70
TOTAL	270,2

Manufacturing process, added to the final price of the product, includes:

-welding

-milling

-cutting

-fabrication of ABS Plastics

By calculating of all parameters and components the retail price of the designed cocktail machine is 480 €. This price includes manufacturing price, material price, VAT, unexpected expenses and profit.

Estimated cost of the Thesis is determined by a formula:

$$P = M + S_m + S_a + D + A + P_{BT} + P_E + E + P_O + VAT, \quad (4.39)$$

where M -price for the material

S_m -main salary of workers,

S_a -additional salary

D-deduction on social needs

A-assistance of other organisations

P_{BT} -price for business trips

P_E - price for technological electric power

E-price for the equipment

P_O -overhead price

VAT-value added tax

According to this formula estimated cost of the Thesis is:

$$P = 270 + 3400 + 410 + 1300 + 2000 + 200 + 200 + 1000 + 6800 + 3875 = 19455 \text{ €}$$

SUMMARY

During the work on the thesis the solutions were found to all the listed tasks.

According to the overview of all existing analogs several main problems in designs of cocktail machines were found:

- low performance;
- high price;
- inconvenience;
- unattractive appearance.

A cocktail machine, developed in this work solves all the listed problems:

- performance is up to 60% higher, depending on the analog;
- price is lower, than any of existing analogs of the same type;
- user-friendly interface and easiness in work;
- elegant design.

Also, the developed cocktail machine is able to produce bigger variety of cocktails and has higher capacity, than most of the analogs.

Due to all this points, the result of the work looks like more than successful. Plans for the future are to create a code for the cocktail machine, develop possible modifications and bring the machine to reality.

KOKKUVÕTE

Töö käigus on töötatud välja ja esitatud väitekirjas lahendused kõigile loetletud ülesannetele. Vastavalt ülevaatele kõikidest olemasolevatest analoogidest on toodud välja mitmeid peamisi probleeme turulolevate kokteilimasinate osas:

- vähene täitmisvaru;
- kõrge hind;
- ebamugav kasutamine;
- ebaatraktiivne välimus.

Käesolevas töös väljatöötatud kokteilimasin lahendab kõik järgnevalt loetletud probleemid:

- tootlikkus on kuni 60% kõrgem, võrreldes analoogidega;
- hind on madalam, kui mistahes sama tüüpi olemasolevatel analoogidel;
- ülevaatlik liides ja hooldusvaba töö;
- elegantne disain.

Väljaarendatud kokteilimasin suudab toota suurema valiku erinevaid kokteile ja on suurema võimsusega, võrreldes enamiku analoogidega.

Seega võib teha järelduse, et töö tulemus on edukas. Tulevikus on plaan luua kokteilimasina tarkvara, töötada välja võimalikud muudatused ja realiseerida masin praktiliselt.

LIST OF REFERENCES

1. Carriere, A., Munz, S., Titas P., Wobith, J. The Perfect Pour, 2014 (Report)
2. Chalcraft E., Makr Shagr by Carlo Ratti and MIT Senseable City Lab-Dezeen Journal, 2013 (14.04.2017) (<https://www.dezeen.com/2013/04/21/makr-shagr-robotic-bar-by-carlo-ratti-and-mit-senseable-city-lab/>)
3. Makr Shagr Carlo Ratti Associati, 2013 (14.04.2017) (<http://www.carloratti.com/project/makr-shagr/>)
4. Manderbach B., The Qube-the cocktail machine-Igus (10.04.2017) (http://www.igus.eu/wpck/5423/manus_qube)
5. Trout C., Sorry 007-Engadget, 03.01.2015 (12.04.2017) (<https://www.engadget.com/2015/03/20/the-430-dollar-robotic-bartender/>)
6. Stephens C., 300 Cocktails at the touch of a Screen-PSFK, 20.01.2015 (12.04.2017) (<https://www.psfk.com/2015/01/somabar-cocktail-maker.html>)
7. Payne V., Robotic bartender machine-CNN Home, 10.01.2015 (09.03.2017) (<http://edition.cnn.com/2014/01/10/tech/innovation/monsieur-bartending-machine/>)
8. Turi J., Monsieur robotic bartender- Engadget, 10.01.2013 (09.03.2017) (<https://www.engadget.com/2013/10/01/monsieur-robotic-bartender/>)
9. Marsteller A., Cocktails in a capsule? The future is here-Liquor.com, 18.06.2015 (10.03.2017) (<http://www.liquor.com/articles/cocktails-in-a-capsule/#gs.6Dn54n0>)
10. Welcome-Xpresscocktail (10.03.2017) (<http://en.xpresscocktail.com/#!>)
11. Bartendro-A cocktail dispensing robot-Kickstarter, (12.02.2017) (<https://www.kickstarter.com/projects/partyrobotics/bartendro-a-cocktail-dispensing-robot/updates>)
12. Duralumin-Chemistry Learner, (05.04.2017) (<http://www.chemistrylearner.com/duralumin.html>)
13. Полистирол Ударопрочный-Newchemistry.ru, (07.04.2017) (<http://www.newchemistry.ru/material.php?id=14>)
14. Spirit Dispensers-Bonzer, (21.01.2017) (<http://www.bonzer.co.uk/products/bar-wine/measures-pourers/spirit-dispensers/en>)
15. Food Handling and Equipment-Plastics International, (17.04.2017) (http://www.plasticsintl.com/food_compliant_materials.html)
16. Tecamid-Gsnab, (17.04.2017) (<http://gsnab.ru/tekamid--tecamid>)
17. Ременные передачи-Detalmach, (16.02.2017) (<http://www.detalmach.ru/lect8.htm>)
18. Stepper Motor-Wikipedia, (18.02.2017) (https://en.wikipedia.org/wiki/Stepper_motor)
19. Arduino-Wikipedia, (23.04.2017) (<https://en.wikipedia.org/wiki/Arduino>)
20. Controlling a Stepper Motor With an Arduino-Instructables, (23.04.2017) (<http://www.instructables.com/id/Controlling-a-Stepper-Motor-with-an-Arduino/>)
21. HC-SR04, (25.04.2017) (<http://amperka.ru/product/hc-sr04-ultrasonic-sensor-distance-module>)
22. How to connect reed switch to Arduino, (25.04.2017) (<http://soltau.ru/index.php/arduino/item/358-how-connect-reed>)
23. Tarasov, A., Balbarov, V. Gear-Belt Drives, Ulan Ude, 2006
24. Anuriev, V. Constructors reference book, Moscow, 2001

25. 17HS4401, (29.01.2017) (<http://roboshop.spb.ru/17HS4401>)

26. FL42STH47-1684M-AB, (29.01.2017)

(<https://stepmotor.ru/%D0%BA%D0%B0%D1%82%D0%B0%D0%BB%D0%BE%D0%B3/fl42sth47-1684m-ab>)