



TALLINN UNIVERSITY OF TECHNOLOGY  
SCHOOL OF ENGINEERING  
Department of Materials and Environmental Technology

# **SUSTAINABLE HYDROGEN FUEL PRODUCTION RELY ON PHOTOVOLTAIC ENERGY**

REVIEW ARTICLE

**Mehmet Ender USLU**

Tallinn, 2021

# Table of Contents

INTRODUCTION	- 3 -
<b>1. GREEN HYDROGEN ECONOMY &amp; CORE TECHNOLOGIES</b>	<b>- 5 -</b>
<b>1.1 Hydrogen Economy</b>	<b>- 5 -</b>
<b>1.2 Hydrogen Evolution Reaction (HER) in Water Electrolysis</b>	<b>- 7 -</b>
Tafel Slope	- 8 -
Faradaic efficiency	- 9 -
Stability	- 9 -
Electrocatalyst	- 10 -
<b>1.3 Hydrogen Storage Technologies</b>	<b>- 11 -</b>
Compressed hydrogen	- 12 -
Cryogenic storage of liquid hydrogen	- 13 -
Chemical storage of metal hydrides and ammonia	- 14 -
Physisorption of hydrogen	- 14 -
Metal Hydrogen	- 15 -
<b>2. PHOTOVOLTAIC (PV) BASED HYDROGEN ENERGY SYSTEMS</b>	<b>- 16 -</b>
<b>2.1 Photocatalyst in Water Electrolysis</b>	<b>- 16 -</b>
<b>2.2 Solar-Hydrogen Stand-Alone Systems &amp; Technical Challenges</b>	<b>- 17 -</b>
<b>2.3 Designs for Solar-Powered Hydrogen Production Plants</b>	<b>- 20 -</b>
<b>2.4 Cost Assessment in PV-Hydrogen Production</b>	<b>- 21 -</b>
<b>3. CONCLUSION</b>	<b>- 26 -</b>
Limitations	- 26 -
Prospectives	- 26 -
REFERENCES	- 27 -

## INTRODUCTION

Hydrogen shines out as the primary future fuel, which has a great potential for replacing fossil fuels. The beginning of hydrogen history as a source of energy lies behind the last quarter of the 18th Century, although it still has many technological challenges today. The discovery of electrolysis by William Nicholson and Anthony Carlisle, followed Alessandro Volta's announcement for the first voltaic pile in 1800, became the starting point of physical chemistry in the 19th Century. In this way, the first hydrogen fuel cell, which converts hydrogen into the electrical current on the principle of reverse electrolysis, was mentioned independently by Welsh physicist William Grove [1] and German physicist Christian Friedrich Schönbein in 1838. However, the first practically successful hydrogen fuel cell could be built only in 1959 by English engineer Francis Thomas Bacon. Afterward, electrochemist John O.M. Bockris is the one who first introduced the concept of hydrogen economy during a meeting at General Motors Technical Center in Michigan in 1970. He later published this new concept of solar-hydrogen energy alternative as a sustainable idea that can compete and replace fossil fuels in aspects for the economy [2].

Since then, scientists have adapted hydrogen as fuel in the use of many vehicles and transportation technologies. American National Aeronautics and Space Administration (NASA) currently uses liquid hydrogen as a primary fuel in their rocket propulsion technology since 1960. Moreover, Samsung Heavy Industries and Bloom Energy announced in 2020 a partnership to design hydrogen fuel-cell powered vessels for zero carbon emission [3]. On the other hand, the automobile industry has addressed no cost-efficient way to replace hydrogen as a fuel with combustion engines, except there are already many attempts about it. The biggest challenges in hydrogen technology for the automobile industry are hydrogen production and distribution infrastructure costs. Levelized Cost for Energy Analysis (LCOE) on a \$/MWh basis [4] result between 103\$-152\$ for the hydrogen fuel cell, which is comparatively more expensive than other energy generation technologies for urban vehicles. However, many researchers believe that hydrogen can supply enough sustainable and alternative power for aerospace jet engines, cargo vessels, space missions. Furthermore, hydrogen has a great potential to be the primary power source for nuclear fusion reactors in the future. The fusion reactors, rather than fission, bring together two isotopes of hydrogen, nuclei of deuterium and

tritium, to merge them into helium nuclei as producing more energy than it consumes. China, cooperating with France, succeeded in running 20 seconds fusion reactor called Tokamak with an output of 500 MW in December 2020. Let's point out that fusion reactions do not allow nuclear contaminations.

At this point, we have a pretty critical issue: To talk about the renewability of hydrogen energy, we are constrained to utilize only renewable methods to produce it, such as solar and wind energy. In this review article, I discuss the sustainability of hydrogen energy bearing production technologies, actual problems, the ultimate technological developments.

This review defines the green hydrogen economy and why we need it in environmental aspects, and then introduces core technologies necessary for the hydrogen economy. The feasibility of PV-powered-hydrogen production for sustainability and cost is also discussed. In the conclusion part, the main limitations in the current technology for green hydrogen production combined with photovoltaic energy, and future perspectives are addressed.

## **1. GREEN HYDROGEN ECONOMY & CORE TECHNOLOGIES**

### **1.1 Hydrogen Economy**

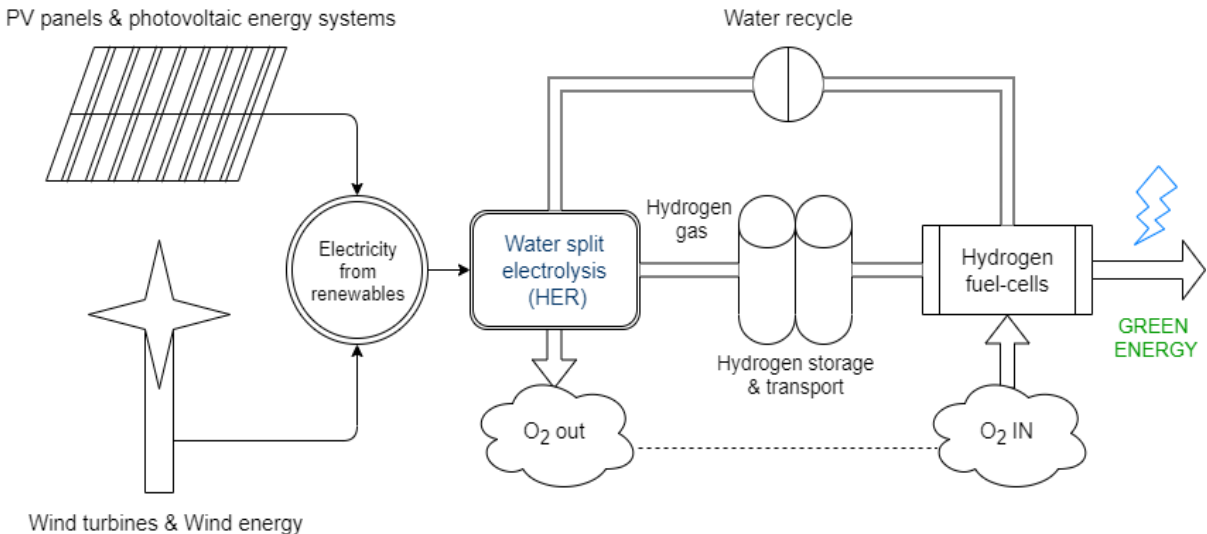
Carbon dioxide has the largest share of global greenhouse gas (GHG) emissions with around 75 percent by The Intergovernmental Panel on Climate Change report 2014 (IPCC 2014), as 65 percent of CO<sub>2</sub> emission comes from fossil fuel of industrial processes, and the 10 percent share is from the sustainable cycles. Environmental Protection Agency (EPA) developed the global warming potential (GWP) to compare global warming impacts of different greenhouse gases (GHGs), from which CO<sub>2</sub> has a GWP of 1 because it is the gas used as the reference. It defines how much heat energy a 1 ton of the emitted GHG can conserve over a given period, usually 100 years. Although the value of GWP for carbon dioxide is lower comparing to GWP from other GHGs, it can remain in the atmosphere for a much longer period, up to 1000 years. In this way, it can trigger a booming impact from geostationary GHGs (frozen methane) by melting glaciers because CO<sub>2</sub> caused a rise in the average global surface temperature by 0.2-Celsius degrees since 1930 [5]. That means that even we immediately go into zero carbon dioxide emission, global warming may end up in a thousand years. However, global carbon dioxide emissions per year from fossil fuels rose at least eleven times in the last hundred years reported by EPA again in 2014. If we continue using fossil fuels without any modification in the current energy technology, carbon dioxide emission from the energy industry is expected to rise to 35.8 giga-tons per year in 2040, as reported by the International Energy Agency.

In this manner, renewable energy technologies and solutions, such as wind and solar energy, came on the stage in the last decays as offering a more carbon-neutral energy production. Although the global cumulative solar photovoltaic (PV) plant's capacity has grown by 632 gigawatts since 2000, It is still far from meeting the requirements of increasing global energy need at on-grid sustainability. Wind energy is not a continuous source and already not as abundant as solar energy. On the other hand, the hydrogen economy for using hydrogen as an industrial scale fuel, offered by John O.M. Bockris in 1971 gained popularity until the 1990s, and then met the feasibility problems because of the cost [5]. However, hydrogen production plants of various methods, such as steam-methane-reforming (SMR), coal-gasification, biomass-gasification, thermal-cracking, and electrolysis emerged

at the beginning of the 2000s [6]. Global production and distribution infrastructure of the hydrogen economy initially based on fossil fuels and then has aimed to make a gradual shift on renewable sources, so the grey hydrogen can transit into green hydrogen. Therefore, a sustainable hydrogen economy by electrochemical water splitting combined with renewable energy gained attraction in the last decades [7]. Nevertheless, only 4 % of global hydrogen production comes from water electrolysis, and the average prices of cumulative hydrogen production in the USA and Europe are around 0.1 euro per kW by 2016 [8].

Thereby, the hydrogen economy idea today puts carbon-neutral hydrogen fuel in the center of a sustainable circulation, in which renewable sources (wind, solar, hydroelectric, and hydrothermal) combined with electrochemical water splitting based on advanced functional materials, the global industry, vehicles, and global transportation stand on the hydrogen fuel-cell technology.

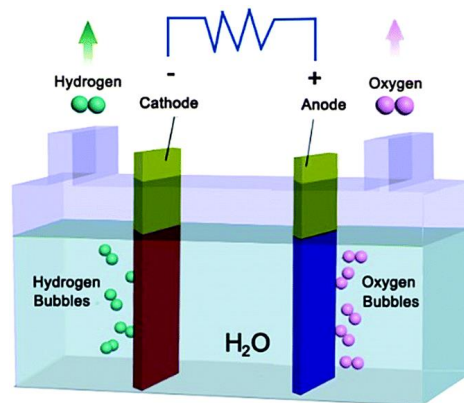
We can refer to many ways to produce hydrogen also from other renewables, such as biological processes (direct biophotolysis), steam reforming, partial oxidation, and the HER from electrochemical water splitting [9]. This review article focuses on the hydrogen evolution reaction (HER) in water electrolysis combined with renewable photovoltaic (PV) energy because it appears to be a cleaner method for the environment.



**Figure 1:** Diagram for hydrogen Economy based on HER & renewables sources.

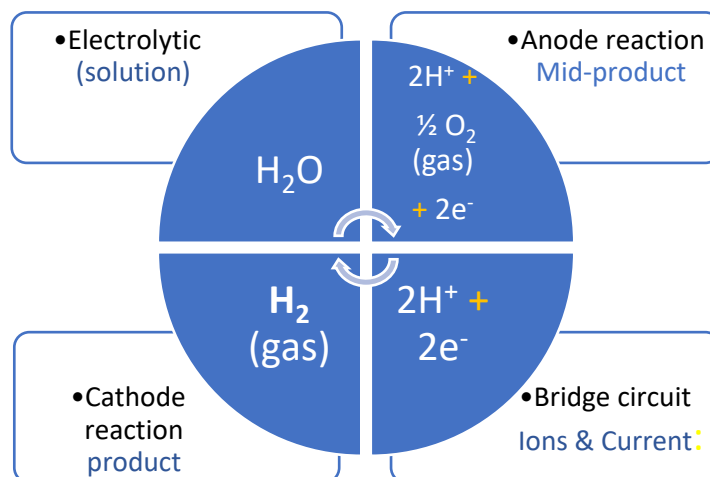
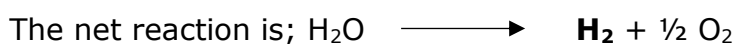
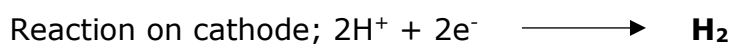
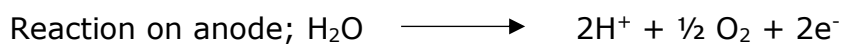
## 1.2 Hydrogen Evolution Reaction (HER) in Water Electrolysis

Water electrolysis is the simplest hydrogen production method we know in zero carbon dioxide emission. Inputs are water and electricity, and outputs are only H<sub>2</sub> and O<sub>2</sub> gasses. Its working mechanism for acidic solutions is a redox reaction that enables molecular ionizations on two poles, as reduction occurs on hydrogen evolution catalyst (HEC) coated on the cathode, and simultaneous oxidation occurs on oxygen evolution catalyst (OEC) surface of the anode electrode [10].

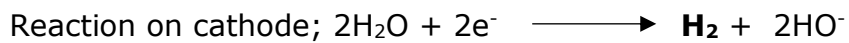
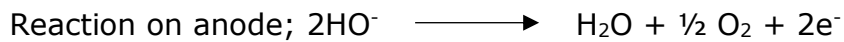


**Figure 2:** schematic of water electrolysis [10]

### In acidic solutions;



### In alkaline solutions;



The reaction works a bit differently in alkaline solutions, as you notice it because its mid-product is Hydroxide ( $\text{HO}^-$ ) rather than the ionized hydrogen atom. The voltage of the water splitting is temperature-dependent, so we can increase it by increasing the electrolytic (the media) temperature. Therefore, we call it thermodynamic voltage. The thermodynamic voltage of water splitting is 1.23 V at 25°C and 1 atm independent of the type of electrolytic solution where the water splitting takes place. Thus, there is a need to apply a potential higher than the sum of the thermodynamic voltage and the excess potential to start water splitting in the cycle. We use this excess potential to overcome intrinsic activation barriers ( $\eta$ ) on the anode ( $\eta_a$ ), on the cathode ( $\eta_c$ ), and other resistants in the solution. Therefore, the energy needed to operate electrochemical water splitting at 25°C and 1 atm is [\[11\]](#);

$$E_{\text{op}} = 1.23 \text{ V} + \eta_a + \eta_c + \eta_{\text{other}}$$

There are other parameters we use to determine the quality of the HER process, described below.

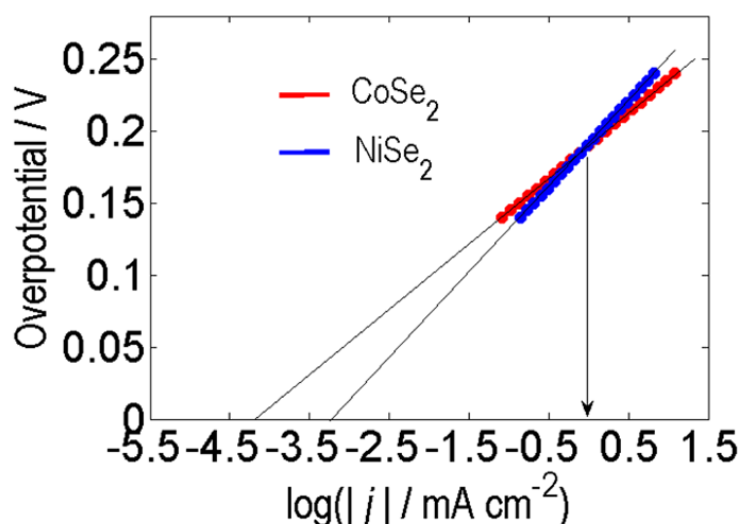
- **Tafel Slope:**

HER electrochemical analysis based on Tafel-equation is preferably utilized in the literature.

$$\text{Tafel equation [12]; } \eta = a + b \cdot \log(j)$$

Where  $\eta$  is the overpotential,  $b$  is Tafel slope, and  $j$  is the current density expressed as  $j_0$  for  $\eta=0$ . A higher value of  $j_0$  is desirable since it represents the intrinsic catalytic activity of the electrode. Moreover, a smaller Tafel slope ( $b$ ) implicitly means higher current-density ( $j$ ) for smaller increments in the overpotential, as a shown example in Figure 3 [\[12\]](#).





**Figure 3:** Tafel plots in comparison of CoSe<sub>2</sub> and NiSe<sub>2</sub> [12]

- **Faradaic efficiency:**

The produced amount of H<sub>2</sub> is directly related to the current density, which means electrons participate in the reaction. Therefore, faradaic efficiency is the ratio between experimentally produced H<sub>2</sub> and the theoretical amount of it. Faradaic efficiency measures as a percentage versus a “specific-electrode-voltage/RHE”. RHE is the abbreviation of reversible-hydrogen-electrode that is used as the reference for electrochemical processes. Its potential linearly depends on the pH value of the electrolyte solution. Therefore, we can calculate RHE-potential as “-0.059V·pH”.

- **Stability:**

It describes the durability and lifetime of HER catalysts in extreme pH (0 - 14) solution environments. Therefore, we measure the current variation by time (I-t curve), or Cyclic voltammetry (CV) that counts the number of cycles tolerated by the electrodes for the varied potential. This cyclic number should be more than 5000 times for considering the electrodes to be stable.

- **Electrolysis methods:**

Polymer-electrolyte-membrane (PEM) since 1960, Solid-oxide electrolysis (SOEC) since 1980 gained attraction by material scientists. We describe the PEM briefly as the electrolysis in a cell equipped with a solid polymer electrolyte (SPE) that allows

the conduction of protons, separates the product gases, and insulates the electrodes.

Essential characteristics, such as current density, cell voltage, and the hydrogen-production rate for alkaline, polymer-electrolyte-membrane (PEM), and solid-oxide electrolyzer cells (SEOC), are compared in Table 1 [13].

Table 1	<b>Alkaline</b>	<b>PEM</b>	<b>SEOC</b>
<b>Current Density (ma/cm<sup>2</sup>)</b>	0.2 – 0.4	0.6 - 2	0.3
<b>Cell voltage (V)</b>	1.8	1.8	1.07
<b>H<sub>2</sub> rate (kg/h)</b>	66.827	25.077	0.087

**Table 1:** Essential characteristics of three electrolyzers [13].

- **Electrocatalyst:**

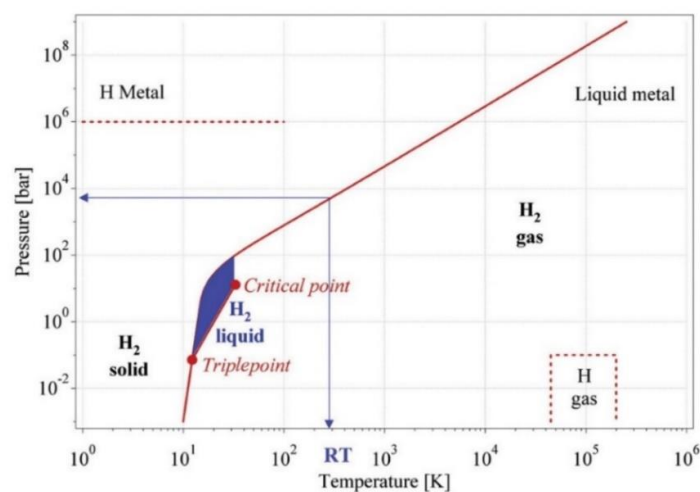
An electrocatalyst enhances the electrochemical reaction on the surface of the electrode. For this reason, the choice of the material as an electrode is a critical issue in the HER reactions. The heavy metals as electrodes in the HER processes with high activity are Palladium (Pd), Rhodium (Rh), Rhenium (Re), Cobalt (Co), Nickel (Ni), and Platinum (Pt). However, many of them are earth-rare elements, while Cobalt and Nickel are the most commercialized ones. For example, Platinum (Pt), gained attraction as a catalyst in Hydrogen involved electrochemical reactions since the early 19th century. Experimental HER activity for the Platinum surface is 1 mA/cm<sup>2</sup> for hydrogen binding energy ( $\Delta E_n$ ) of 3 eV [8] and with a faradaic efficiency of 85 % approximately. Although the electrocatalytic activity of Pt is pretty high, platinum is an expensive, earth-rare noble metal. Therefore, scientists conducted numerous studies for alternative low-cost and efficient catalysts, such as active metals, metal sulfides, metal selenides, and carbon nitrates [14]. An experimental study for the search of alternative HER catalysts has shown that MoS<sub>2</sub> thin-film coated graphite [15] can be an active catalyst in the HER, but with lower current densities compared to conventional Pt electrodes. Metal sulfides are low-cost alternative electrocatalysts for the HER [16], but further researches are needed to understand how their structure influences the HER activity. Therefore,

to overcome the limitations of MoS<sub>2</sub> thin-films or nanoparticles in the HER, alternative stoichiometric composition of Mo(S,Se)<sub>2</sub> nano-flakes is reported to exhibit higher performance [17].

Nevertheless, the main cost for the H<sub>2</sub> production from the water electrolysis is not the price of the noble metals but is the low conversion efficiency of the system [14]. For example, only 0.1 volts fall in the cell operating voltage of PEM electrolyzers could reduce the cost for H<sub>2</sub> production from the electrolysis by a 0.3 billion euros on the total of 6 billion euros [8]. On the other hand, the surface morphology of the electrodes has a significant influence in catalyzing the electrolysis. Thus, substrates coated by different Pt nanostructures can be a way to reduce the material cost and increase the efficiency [18]. Electrocatalysts are vitally critical for the applicability of the HER system efficiency on an industrial scale.

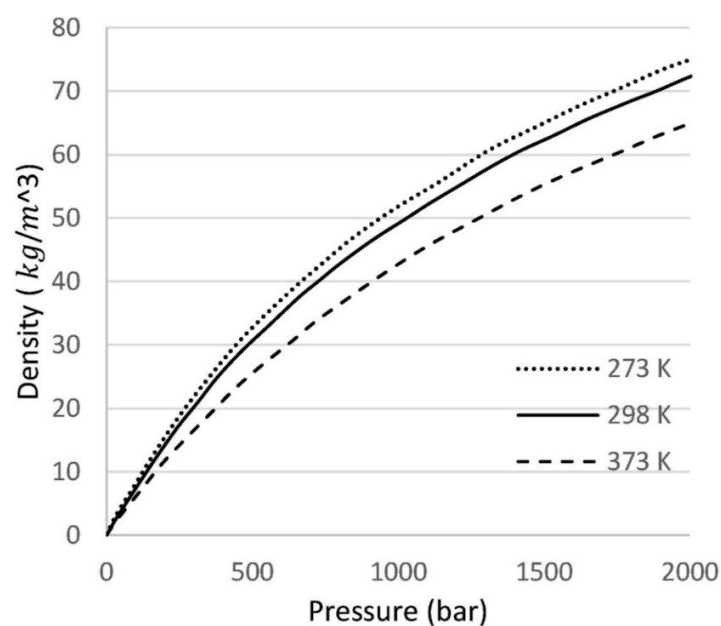
### 1.3 Hydrogen Storage Technologies

Hydrogen storage is one of the most challenging problems in the hydrogen economy. Hydrogen storage methods need to be cost-effective, and reliable for allowing direct consumption in hydrogen fuel cell vehicles. Scientists keep putting a great effort into more energy-dense and safe storage methods. So far, they have invented various hydrogen storage methods, such as compressed hydrogen gas, cryogenic storage of liquid hydrogen, physisorption of hydrogen [19], chemical storage of metal hydrides and ammonia [20].



**Figure 4:** Primitive phase diagram for hydrogen [19].

An efficient hydrogen storage method should have a high energy density in aspects of the hydrogen economy because hydrogen stored in higher densities replaces less volume, less material, and easiness in transportation. However, as you can see in figure 5, the storage of hydrogen in higher densities does not have a linear relationship with the cost of the pressure. High energy density also brings extra costs for further compression at nominal temperatures. Decreasing the hydrogen temperature as an alternative option for increasing energy density is another cost problem.



**Figure 5:** The change of the volumetric density of normal hydrogen versus the applied pressure for three different temperatures [21].

- **Compressed hydrogen**

Hydrogen has three isotopes of protium (H), deuterium (D), unstable one tritium (T), which can have gas forms of H<sub>2</sub>, D<sub>2</sub>, T<sub>2</sub>, respectively, under 0°C and 1 bar [19]. Storing hydrogen as compressed gas has three types: storage vessel, geological storage, and other underground storage methods [22]. Storage vessels can allow high energy density and transportation easiness, as geological storage can be more cost-efficient depends on the local geographic conditions. Some of the storage solutions, such as blending hydrogen into natural gas pipelines might be practical in aspects of transportation.

Brief definitions for the compressed storage methods are given in Table 2 to make an overlook and get a general understanding. All these methods have technologies based on compressing the gas hydrogen at higher pressures as much as possible without sacrificing safety.

Storage vessel	<ul style="list-style-type: none"> <li>• High pressure gas cylinders of aluminium, steel, and adhered thin metal-fiber resin composite.</li> <li>• Maximum pressure: 20 - 80 MPa</li> <li>• Max hydrogen volumetric density: 36 kg·m<sup>3</sup></li> </ul>
Geological storage	<ul style="list-style-type: none"> <li>• Depleted gas reservoirs, salt caverns, abandoned mines, rock caverns.</li> <li>• Pressure : 5.2 - 15.2 MPa</li> </ul>
Other underground Technologies	<ul style="list-style-type: none"> <li>• Blending hydrogen into natural gas pipelines: adding hydrogen to natural gas will decrease CO<sub>2</sub> emission from the burn while supplying the same amount of energy.</li> <li>• Drawbacks: High pressure in pipelines, leakage risk in end users.</li> </ul>
Other underground Technologies	<ul style="list-style-type: none"> <li>• Underground methanation reactor (UMR): The Sabatier's reaction of hydrogen and carbon dioxide at high temperatures in a depleted gas reservoir, where the methanogenic bacteria catalyze the reaction.</li> </ul>

**Table 2:** Compressed hydrogen storage methods [22].

### • Cryogenic storage of liquid hydrogen

Cryogenic hydrogen has a density almost twice that of compressed hydrogen at 70 MPa. Cryogenic tanks have sizes that can range from 1.5 m<sup>3</sup> (100 kg) to 75.0 m<sup>3</sup> (5,000 kg) [23]. The inner sheet of the tank typically has multilayer insulation of metals and glass wool, and with a vacuum in the space between the inner and outer shells [24].

Hydrogen has a critical temperature of 33K for liquefaction at ambient pressure. The current cooling systems for hydrogen liquefaction are based on the Joule-Thompson cycle, where the cooled gas separated from the liquid is pumped back to the heat exchanger. In the heat exchanger, liquid nitrogen is utilized. Liquefied hydrogen stored in cryogenic tanks at 21K has a risk of high pressure around the critical temperature because of heat leakage.

The free enthalpy change from gaseous hydrogen at 300 K to the liquid one at 20 K is 11640 kJ/kg, which requires theoretical energy (work) for hydrogen liquefaction of 3.23 kWh/kg, but the experimental work we measure is about 15.2 kWh/kg because of the non-ideal system loses [19]. This energy needed for liquefaction is about twice that (6.0 kWh/kg) required for compression to 70 MPa at RT [23]. However, cryogenic hydrogen tanks are much lighter than compressed hydrogen tanks, and they also can occupy fewer volumes up to three times for the same energy content [24].

- **Chemical storage of metal hydrides and ammonia**

Hydrogen can be defused chemically by extreme conditions of pressure and temperature into specific metal compositions. Metal hydrides can absorb hydrogen for around 5-9 % of their mass at temperatures 2500°C or higher [25]. Metal hydrides tend to bond chemically with hydrogen absorbed, so for releasing it back, they require to heat up to 200°C. Some of the metal hydrides with higher energy density, and more safety, are reported as NaAlH<sub>4</sub>, AlH<sub>3</sub>, MgH<sub>2</sub>, Mg(BH<sub>4</sub>)<sub>2</sub>, Li<sub>2</sub>NH [26].

On the other hand, ammonia has developed historical production, storage, and transportation infrastructure [27]. Ammonia mixed with water and stored in liquid form at slightly low temperatures can provide hydrogen of high energy density via catalytic decomposition [28]. The enthalpy change required to convert ammonia from liquid to gas-phase is around 20 kJ/mol, and then to decompose it into the hydrogen and nitrogen gases needs the extra energy of 46 kJ/mol [29]. A large share of the price for ammonia production with 75 % comes from the price for methane.

- **Physisorption of hydrogen**

Physisorption of hydrogen is much safer than compressed gas and cryogenic storage methods. We can define physisorption as adsorption of H<sub>2</sub> on the surface of porous mater, mostly giving no chemical reaction. Any microporous (less than 2 nm) surface material that has the ability of Van der Waals (VDW) interactions can absorb hydrogen. The challenge in this method is that stronger Van der Waals (VDW) interactions require lower absorption temperatures.

Especially in recent studies, allotropes of carbon offer different porous surface structures and electrostatic interaction with hydrogen to keep it on the material surface. Therefore, Scientists work on well-designed nano-surfaces rather than randomly porous ones. That is, they reported single-wall carbon nanotubes (SWNTs) with 10 wt. % at 273 K and 0.04 MPa [30], Nano-structured graphite with 7.4 wt. % at 300 K and 1 Mpa [31], MoS<sub>2</sub> nanotubes with 1.2 wt. % at 298 K and 2 MPa [32], TiS<sub>2</sub> with 2.5 wt. % at 298 K and 4 MPa [33] in the literature of the last decades. Transition metal carbides, and nitrides of a few atoms-thickness, called MXenes-2D materials, also gained attraction for their hydrogen storage capacity as Ti<sub>2</sub>C has shown pretty high adsorption up to 8.6 wt. % [34].

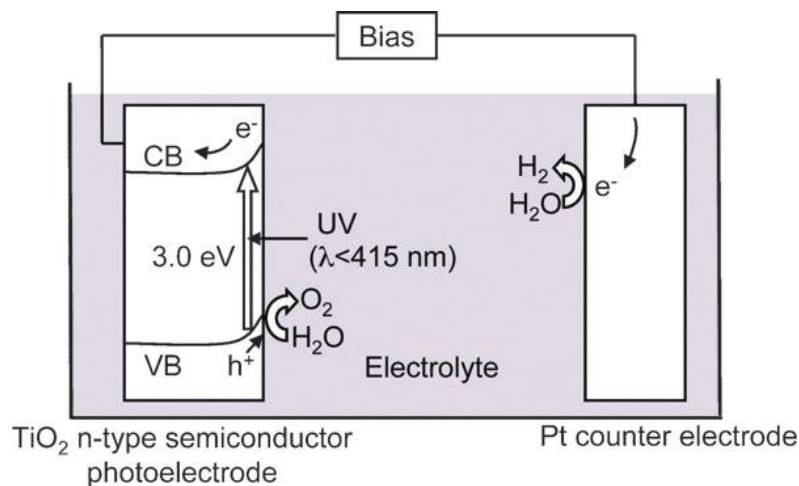
- **Metal Hydrogen**

Hydrogen has a melting point of 14 K, so it would remain solid below this temperature. In 1935, E. Wigner and H. B. Huntington theoretically asserted that solid hydrogen under the immense pressure of 25 GPa would transit from molecular to crystalized structure [35]. That is, it would change into the metal phase. Once it turned into the metal phase, it can remain metastable liquid metal at room temperatures due to previously exerted gravitational compression. Therefore, N.W. Ashcroft theoretically showed in 1968 that liquid metallic hydrogen can be a room-temperature superconductor [36]. Fifty years later, a scientific breakthrough finally came true, and Paul Loubeyre, Florent Occelli & Paul Dumas experimentally succeeded metal hydrogen under 425 GPa, at 80K in 2019 [37], and the team used toroidal diamond anvil cell (T-DAC) technology to exert this enormous pressure on hydrogen [38]. Metastable metallic hydrogen is quite attractive as low volume powerful rocket fuel because it can shrink the volume of fuel-tank by a factor of 6 times comparing to cryogenic hydrogen and supply many times more energy densities [39]. This is a revolutionary achievement in material science not only for rocket technology in space missions but also for fusion reactors, although it remains an expensive option for land transport.

## 2 PHOTOVOLTAIC (PV) BASED HYDROGEN ENERGY SYSTEMS

### 2.1 Photocatalyst in Water Electrolysis

The very first PV application for carbon-neutral hydrogen energy systems starts in HER from water electrolysis. Semiconductor materials have applications as photocatalysts in water electrolysis for increasing conversion efficiency. That is, sunlights hit on photocatalysts immersed in the electrolyte can enhance the water electrolysis efficiency. Akira Fujishima and his team introduced the Honda–Fujishima effect of water splitting using a  $\text{TiO}_2$  electrode in 1972, as shown in figure 6 [40]. The team showed that water electrolysis powered by  $\text{TiO}_2$  n-type semiconductor in the anode, and Pt electrode in the cathode site, can produce hydrogen without an applied voltage because it already generates an excess potential around 0.15 eV between the two poles [41]. For facilitating such a reaction without an applied voltage, the conduction band minimum (CBM) of the n-type photocatalyst should be at least -0.4 eV more negative than the standard hydrogen electrode (SHE) in acid solutions or -1.2 eV more negative in alkaline solutions. If the fermi energy of the photocatalyst is more negative than the counter electrode's fermi-level, regarding SHE energy, photogenerated electrons at the photocatalyst can flow to the cathode without external energy application.



**Figure 6:** Water electrolysis using  $\text{TiO}_2$  photoelectrode [40].

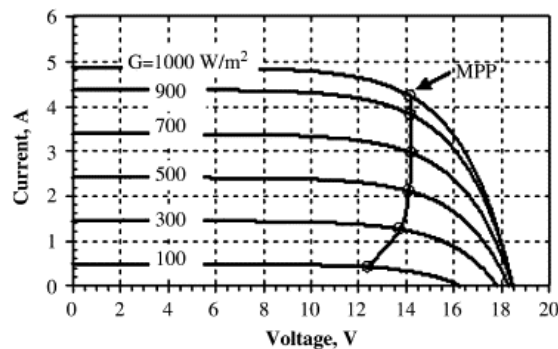
Although the efficiency of this setup was disputed, scientists reported numerous promising photocatalysis materials in the last decades, like  $\text{CaTiO}_3$  and  $\text{SrTiO}_3$  [42].



## 2.2 Solar-Hydrogen Stand-Alone Systems & Technical Challenges

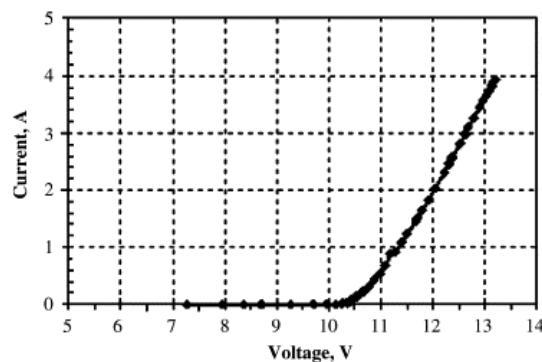
Battery packs in PV systems have limited storage with a high cost for off-grid power for household users. Therefore, maybe we can decrease the cost and increase sustainability by replacing some of the battery packs with hydrogen storage.

We need to achieve near maximum power transfer between PV panels and electrolyzer subsystems. Thus, we have to make the theoretical design for optimal matching between the I-V (current-voltage) curve of PV panels and electrolyzer in a direct coupling system. In figure 7, you can see that how the maximum power point (MPP) of a solar panel, with a 75 W capacity, changes regarding the change in solar radiation intensity.



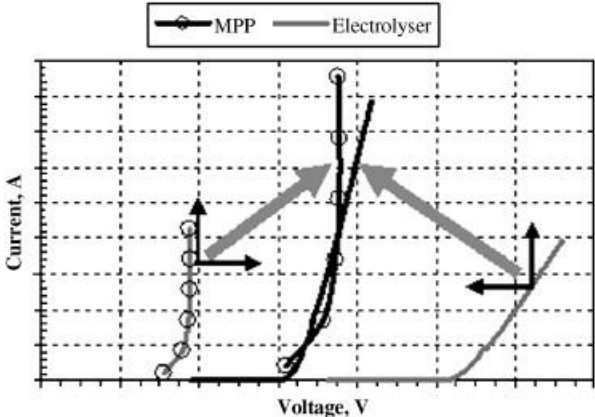
**Figure 7:** MPP I-V curve versus solar radiation intensity in 75 W PV modul [43].

We can couple such PV panels with a PEM electrolyzer of 50 W - 14 V DC, which has I-V characteristics in figure 8. In the reported design [43], researchers suggest that we can cancel the voltage difference between two I-V curves from the electrolyzer and PV panel and increase the energy transfer with an optimum configuration of unit arrays.



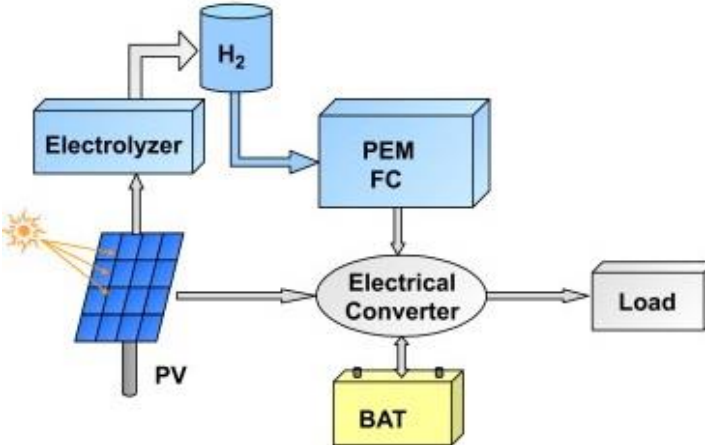
**Figure 8:** I-V characteristic of 50 W PEM electrolyzer [43].

For example, a parallel grouping of the PV array would shift the MPP voltage to the voltage values of the PEM without any modification in the current. We can also shift the PEM voltage with a parallel connection of electrolyzer units in the same way. For the current optimization, which depends on the solar radiation intensity, different configurations of serial connections seem pretty possible. The matching of maximum power points is shown in figure 9 [43].



**Figure 9:** Energy transfer matching between PV module and PEM electrolyzer [43].

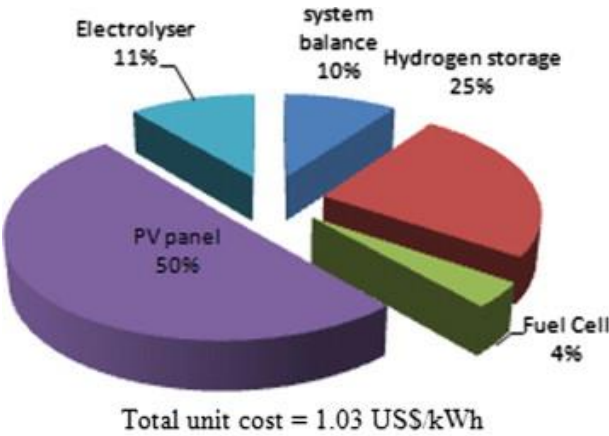
Another research group sized a full-scale stand-alone design shown in figure 10 for house usage with taking consideration of a 10 % efficient - 1 m<sup>2</sup> PV panel, 40 % efficient FC-PEM electrolyzer, and regular lead-acid battery in the cost and efficiency calculations [44]. The system designers assume to achieve 1.6 MWh on m<sup>2</sup> per year from the sun irradiation.



**Figure 10:** A stand-alone system configuration for house energy [44].

In this stand-alone system, when solar power is too weak and the battery is high enough, the fuel-cell does not work. When solar power rises, the PV module supplies total energy and also charges the batteries. After batteries are charged up, PEM electrolyzers are activated for hydrogen production. Then, the hydrogen tank will be full too as a backup energy source. The cost calculated over 20 years of system working is 0.645 €/kWh with an overall system efficiency of 50 %. Fuel-cell can supply 50W alone, which less than that by PV and either that by batteries. That is, if the system would be without batteries, the cost would be 4.943 €/kWh with an overall efficiency of 22.4 %. Therefore, it is possible to say that a solution using the only hydrogen tank (without battery backup) is not economic one [44].

On the other hand, fuel-cell conversion efficiency is also an issue for the overall system efficiency. Although numerous studies have been made also for improving the conversion efficiency of hydrogen fuel cells, they lose a large share of the energy as heat with an average conversion efficiency of 60 percent at the commercial level [45]. In this manner, researchers reported designs like utilizing both electricity and heat outcome from a hydrogen fuel cell. For example, they conducted on the visual-based platform, Delfi, that the average cost of electricity for a household is 1.03 \$/kWh, over 20 years of a period, with a 0.3 kW size fuel-cell if the system is complemented by a conventional solar-water heating system and does not waste the heat [46]. I will draw your attention to that in the simulation there is no battery pack included, as the shares of the main price contributions shown in Figure 11.



**Figure 11:** Analysis of the contributions of the main components to the unit cost [46].

Researchers prefer some kind of algorithms to evaluate such energy systems rather than experimental setups. They reported compared results from three algorithms, called Prophet, SGD, and SARIMAX, for the Photovoltaic-Electrolytic (PV-E) system for hydrogen production [47]. For example, another theoretical design of a PV-powered hydrogen production unit for a glass production factory in Algeria, using a software, concluded that the specific energy of production needs the value of 3.95 kWh/Nm<sup>3</sup> H<sub>2</sub>. They reported that such a design would require 1000 - kW PV modules, 200 batteries, and a 10 kW converter with the Levelized cost of electricity (LCOE) of 0.445 \$/kWh over three years of period [48].

### **2.3 Designs for Solar-Powered Hydrogen Production Plants**

The concept of PV energy-powered industrial-scale hydrogen production plants has question marks for feasibility, overall energy efficiency, Levelized cost of electricity (LCOE), and energy sustainability. Between 1986 - 91, Solar-Wasserstoff-Bayern GmbH, together with Federal German & Bavarian governments, established a large PV- hydrogen production plant in Neunburg Vorm Wald in Germany to test solar-hydrogen technology. The plant included units of Silicon-PV modules, DC/DC converters, AC busbar, two low-pressure water electrolyzers, H<sub>2</sub>/O<sub>2</sub> gas systems, two fuel-cell plants, refueling plant for test vehicles [49]. Also, between 1986 - 93, the Kingdom of Saudi Arabia and Germany cooperated in the demonstration of solar-powered hydrogen production in a 350 kW project called the Hysolar [50]. However, since then, there are no many examples of such large plants because of problems in the overall system efficiency. The whole system is dragged down by the low conversion efficiency in the hydrogen fuel-cell technology.

Another problem that stands out is that hydrogen transportation for vehicles is costly and dangerous because compressed hydrogen in tanks has the risk of high pressure by mechanical vibrations. Therefore, stationary systems case by case can be preferable. For instance, scholars from China and UK proposed airport electrification by a PV - hydrogen hybrid system, which including photovoltaics, electrolyzer, electric vehicles, hydrogen fuel-cell, and battery storage [51]. They reported the total annual cost-saving of the energy by 41.6 % and 67.29 % reduction in CO<sub>2</sub> emission. Moreover, Japanese scholars suggested a promising idea to solve the hydrogen transportation problem for hydrogen-powered cars.

They propose a hydrogen refueling station with PEM electrolyzer supported photovoltaic generation (PV) for supplying hydrogen [52]. They concluded that it is theoretically possible to achieve an optimized system configuration in terms of CO<sub>2</sub> mitigation, operational cost reduction, and electrolyzer capacity utilization.

## 2.4 Cost Assessment in PV-Hydrogen Production

This section starts with defining the Levelized Cost of Electricity (LCOE) for energy production plants: LCOE is the average net cost of electricity over the plant's lifetime for energy produced per hour (\$/kWh). Kilo-Watt per hour (kWh) corresponds to the amount of energy generated by keeping a 1 kW power appliance for one hour. LCOE covers construction, material, and maintenance costs as distributing them over the given period. Thus, this period can be also called payback time by the investors. Every system component has a economic lifetime and conversion efficiency that has an individual contribution to the LCOE. For evaluation of the LCOE, there exist many scenarios that depend on system capacity, if batteries are utilized, if transportation is needed, and if fuel-cell efficiency is considered or not. In the scenario for the transport and fuel-cell not included, we can call it as Levelized Cost of Hydrogen (LCOH<sub>2</sub>). The unit for such measure (LCOH<sub>2</sub>) would be **\$/kg - H<sub>2</sub>**. Components for PV powered-hydrogen production system comprise and their performance that contributes to the LCOH<sub>2</sub> in Table 3.

	<b>Units</b>	<b>Value</b>
A PV array	%	20
DC-DC converter for MPP tracking.	%	95
Li-ion Batteries	%	90
DC bus bars & wires	NA	NA
An industrial electrolyzer (including gas conditioning components)	kWh / kg H <sub>2</sub>	54
Gas compressor and storage tank for hydrogen	NA	NA

**Table 3:** system components and their key parameters in the LCOH<sub>2</sub> [53].

Such system lifetime would be limited by the lifetime of the component that shares the largest portion in the LCOH<sub>2</sub>. We can take into account system lifetime as 20 years since PV modules have about 20 years of effective operation. Cheaper and short-time operating components can be considered in the maintenance budget. Regarding table 3, the overall efficiency of PV-powered hydrogen production is about 72 %. We do not consider the PV array efficiency in the cumulative one, although we count its price in the LCOH<sub>2</sub> tool.

Solar-PV LCOE, wind energy LCOE, PEM electrolyzer LCOE are respectively \$40/MWh, \$30/MWh, and \$70/MWh [54], [55]. These values take into account many parameters as it is discussed in the previous paragraphs. As taking into account 72% overall system efficiency, LCOE for PV, and wind energy subsystems would increase to \$55.55/MWh and \$41.66/MWh, respectively. When considering hydrogen production rate is 25.077 kg/h from the conversion of 0.08799 kg/h = 1 Nm<sup>3</sup>/h for hydrogen gas, we can make a rough comparison for any production system of 1 MW capacity like in Table 4. The system LCOE in Table 4 is the sum of those from subsystems based on serial design connections, and it excludes storage and transportations costs. The industrial SMR is the most convenient method as the result that it has the most competitive LCOH<sub>2</sub> value. However, we expect radical drops in LCOE values for PV and Wind energies in the future, until 2030, as they have been doing since 1970.

	<b>LCOE</b>	<b>LCOH<sub>2</sub></b>
Solar PV - hydrogen Production	\$ 125.55 / MWh	\$ 5 / kg -H <sub>2</sub>
Wind energy – Hydrogen Production	\$ 111.66 / MWh	\$ 4.45 / kg -H <sub>2</sub>
Steam Methane Reforming (SMR) - Hydrogen production [56]	-	\$ 1.5-2.5 / kg -H <sub>2</sub>

**Table 4:** LCOH<sub>2</sub> comparosn for PV, Wind and conventional SMR.

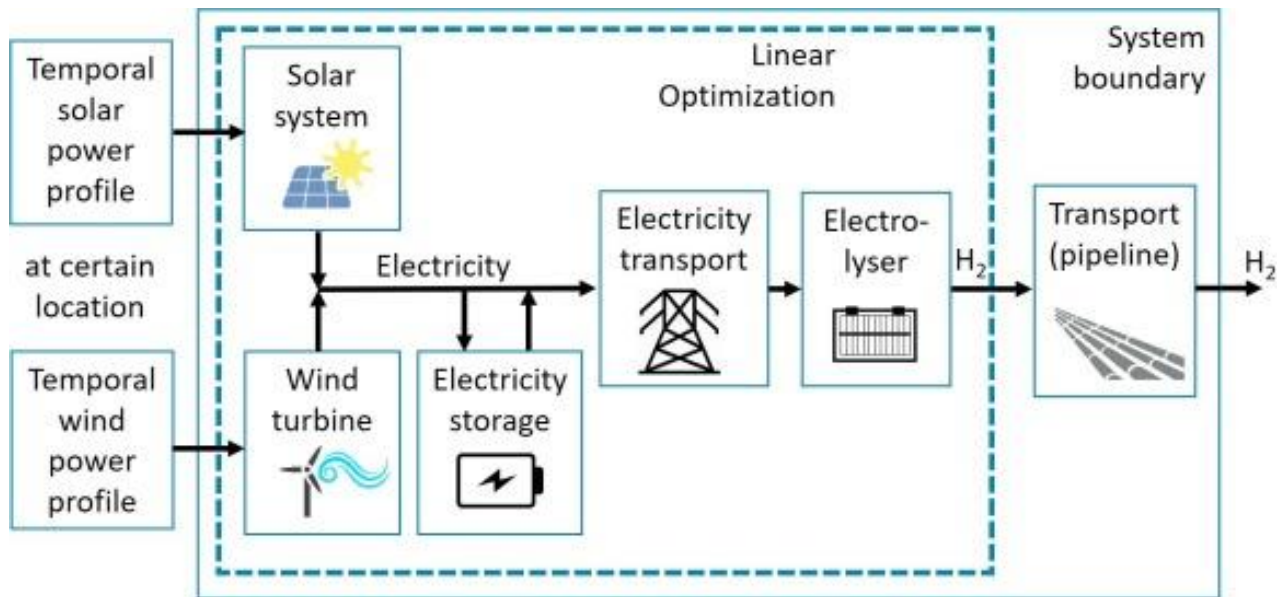
The report published in 2014 by L. Bertuccioli et al., considering the European market's feedbacks, asserts that key performance indicators are efficiency, lifetime, equipment size, capital cost, operating cost: They found that the electrical energy input (kWh/kg H<sub>2</sub>) needed for the PEM electrolysis system is less than that for the Alkaline electrolysis system, beginning from 2020. System scale is linearly dependent on the system cost for the electrolysis production and developing the large cell areas reduces expensive material uses. That is, construction cost drops by around 30 % for the electrolysis system has a capacity greater than 1 MW [57]. USA Department of Energy also made a precise prevision for Hydrogen production from the electrolysis in 2014 in detailed sorts: If a hydrogen production plant of 50,000 kg per day capacity, based on PEM electrolyzer, use % 97 of its maximum, then the LCOH<sub>2</sub> will reduce to 4.2 \$ / kg H<sub>2</sub> in 2025, regarding the USA grid price \$ per kWh [58].

A cost comparison from 2019 between solar and wind subsystem contributions in LCOH<sub>2</sub> for PEM electrolysis is in Table 5 [59].

	Years of operation	Minimum investment costs	Maximum investment costs
PV system	20	985 €/kW	1206 €/kW
Wind turbine	20	1026 €/kW	1766 €/kW
PEM electrolyser	20	700 €/kW	1300 €/kW
Li-ion battery	10	271 €/kW	324 €/kW
Transmission line	20	33 €/kW/100 km	42 €/kW/100 km

**Table 5:** A comparison of the cost of the hydrogen from different processes [59].

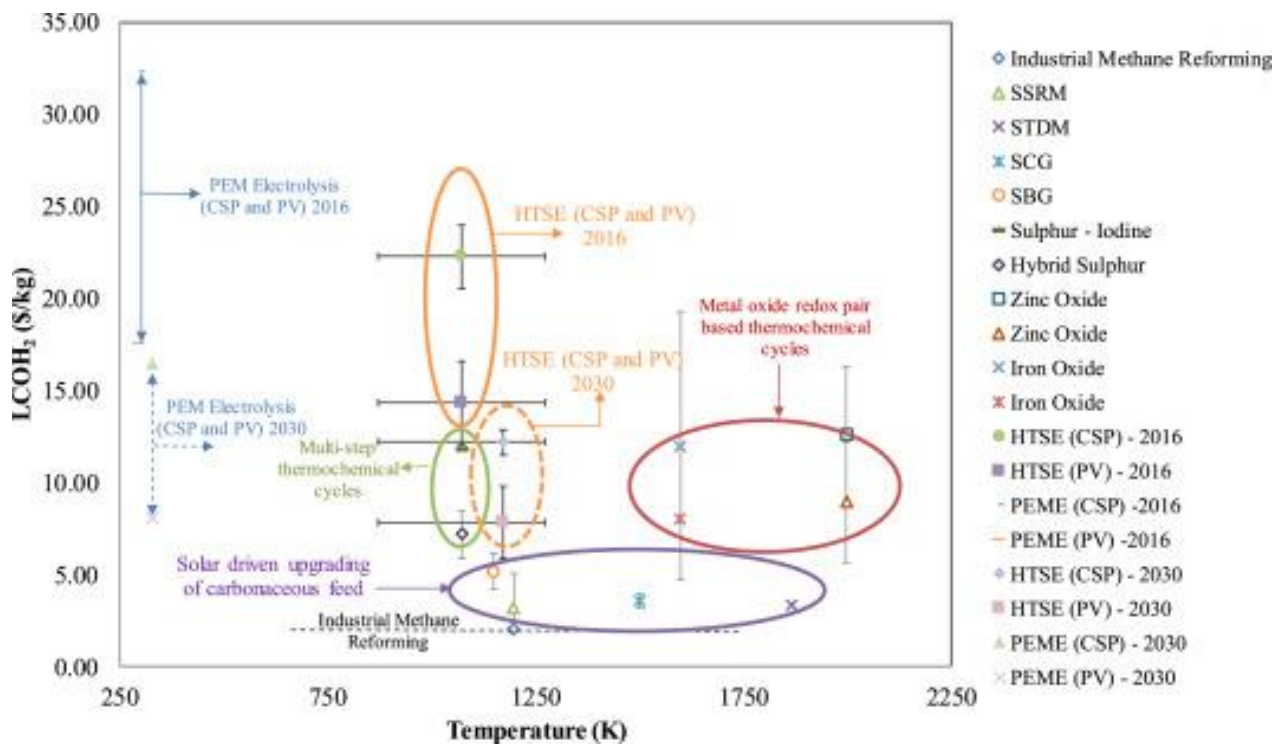
Researchers conducted the cost estimation in Table 5 for a hydrogen production line between North Africa and central Europe, as shown in figure 12, assuming that 9.6 TWh / year energy would be delivered with a 10 % blend of hydrogen within the natural gas pipelines.



**Figure 12:** Hydrogen production from renewables and pipeline distribution between North Africa and Central Europe [59].

Although researchers reported several comparisons for  $LCOH_2$  in different production methods, it is hard to compare directly since the results differ depending on the design, demands, and capacity. Here, In Figure 13, Yadav and Banarje reported  $LCOH_2$  values, based on the current density of 5000-10000 A/m<sup>2</sup>, for Steam Methane Reforming (SMR), Concentrated Solar Power (CSP\_PV), High-Temperature Steam Electrolysis from PV (HTSE\_PV), High-Temperature Steam Electrolysis from CSP\_PV (HTSE\_CSP), Solar Steam Reforming of Methane (SSRM), and Solar Thermal Decomposition of Methane (STDM) for 2016 and also for 2030 perspective [60], [61]. From the economic chart in figure 13, we conduct that there is an expectation of a competitive drop in the  $LCOH_2$  for the CSP\_PV method until 2030. However, industrial methane reforming (SMR), which has the benchmark  $LCOH_2$  in the chart, is still the most preferred industrial method, besides PV-based hydrogen from electrolysis is the most carbon-neutral one. The cost of PV panels is the factor in higher  $LCOH_2$  for hydrogen from PV-electrolysis.





**Figure 13:** Economic chart for solar processed hydrogen methods [60].

Consequently, It shows up that LCOE quite changes by the point of needings and can be improved by smart designs for PV-powered hydrogen production. However, low efficiency in hydrogen fuel-cells remains the main obstacle for the market and drops the expectations.

### **3 CONCLUSION**

- **Limitations**

In this review article, I concluded three main limiting factors described; First, the cost of PV panels and low efficiency from the fuel-cells in the current technology ends up with high LCOE for hydrogen production from PV-powered electrolysis, comparing the other methods. Second, the faradaic efficiency of catalyst for the water electrolysis is another limiting factor. Third, hydrogen storage methods still have lower energy densities comparing the natural gas.

Catalytic activity and so overall system efficiency in water electrolysis can increase in more promising levels With future developments in advanced material. On the other hand, cheaper solar-cell technology and more efficient hydrogen fuel cells in the future will enable large-scale industrial feasibility and attractiveness of the hydrogen from PV-powered electrolysis. Especially low efficiency in fuel-cells will be the biggest challenge in the future. Therefore, hydrogen fuel for individual vehicles remains an expensive alternative, besides they find it attractive for airways and cargo vessels.

- **Prospectives**

We have to push our society and all technological capacity for carbon-neutral energy production because we are on an irreversible edge of the CO<sub>2</sub> emission for the planet-earth. In this manner, Institutions and individual researchers in developed countries, such as Japan [\[62\]](#), Australia [\[63\]](#), NREL from the USA [\[64\]](#), Russia [\[65\]](#), and China [\[66\]](#), published in the last decade their previsions for green hydrogen energy. Further developments in material science and fuel-cell technology have a great potential to cover the gap between efficiency and cost, soon. On the other hand, scientists put great efforts into material researches for alternative hydrogen storage techniques. So far, hydrogen as a backup energy source added to the battery technology in stand-alone applications is feasible within current technology in aspects of efficiency and cost.

Moreover, the discovery of metallic hydrogen is an interesting breakthrough for hydrogen storage. In high probability, metallic hydrogen can be the primary fuel in rocket and nuclear fusion technologies.

## References

- [1] W.R. Grove Esq et al. On a new voltaic combination. The London Edinburgh, and Dublin Philozofical Magazine and Journal of Science, 13 (84), pp. 430-431
- [2] J. O. M. Bockris. The solar-hydrogen alternative. Architectural Press, London, 1976. No. of pages: 365. ISBN 0 85139 583 X
- [3] D. Kessenides and K. Park. Samsung Heavy, Bloom Energy Partner to Develop Zero-Emissions Cargo Vessels. Bloomberg June 30, 2020.
- [4] Lazard ´s levelized lost of energy analysis—Version 12.0. November 2018.
- [5] J. O. M. Bockris. Could this Fuel Replace Gasoline. ECS Transactions, The Electrochemical Society 50 (31) 3-11 (2013) 10.1149/05031.0003ecst.
- [6] L. Barreto, A. Makihira, K. Riahi. The Hydrogen Economy in the 21st Century: A Sustainable Development Scenario. International Journal of Hydrogen Energy, 28 (2003) 267-284.
- [7] H. Zhang, R. B. Wehrspohn and et al. Bifunctional heterostructured transition metal phosphides for efficient electrochemical water splitting. Adv. Funct. Mater. 2020, 2003261
- [8] J. Tymoczko et al. Making the hydrogen evolution reaction in polymer electrolyte membrane electrolyzers even faster. DOI: 10.1038/ncomms10990
- [9] O. Bicakova, P. Straka. Production of hydrogen from renewable resources and its effectiveness. International journal of hydrogen energy 37 (2012) 11563 - 11578
- [10] X. Zouc and Yu Zhang. Noble metal-free hydrogen evolution catalysts for water splitting. Chem. Soc. Rev., 2015, 44, 5148—5180
- [11] T. R. Cook, D. K. Dogutan et al. Solar Energy Supply and Storage for the Legacy and Nonlegacy Worlds. Chem. Rev. 2010, 110, 6474–6502
- [12] A. P. Murthy, J. Theerthagiri, and J. Madhavan. Insights on tafel Constant in the analysis of hydrogen evolution reaction. J. Phys. Chem. C 2018, 122, 23943–23949
- [13] M. Carmo et al. A comprehensive review on PEM water electrolysis. International journal of hydrogen energy 38 (2013) 4901 - 4934
- [14] A. Eftekhari. Electrocatalysts for hydrogen evolution reaction. International journal of hydrogen energy 42 (2017) 11053 - 11077
- [15] B. Hinnemann, J. K. Nørskov et al. Biomimetic hydrogen evolution: MoS<sub>2</sub> nanoparticles as catalyst for hydrogen evolution. J. AM. CHEM. SOC. 2005, 127, 5308-5309
- [16] A. Saha and K. Raghavachari. Hydrogen evolution from water through metal sulfide reactions. The journal of chemical physics 139, 204301 (2013)
- [17] Q. Gong, L. Cheng, Y. Li et al. Ultrathin MoS<sub>2</sub>(1-x)Se<sub>2x</sub> alloy nanoflakes for electrocatalytic hydrogen evolution reaction. ACS Catal. 2015, 5, 2213–2219
- [18] Y. Li , H. Zhang, X. Sun et al. Under-water superaerophobic pine-shaped Pt nanoarray electrode for ultrahigh-performance hydrogen evolution. Adv. Funct. Mater. **2015**, 25, 1737–1744

- [19] A. Züttel. Materials for hydrogen storage. *Materialstoday*, September 2003, pp. 24-33
- [20] S. Niaz, T. Manzoor, A. H. Pandith. Hydrogen storage: Materials, methods and perspectives. *Renewable and Sustainable Energy Reviews* 50 (2015) 457–469
- [21] A. Leon. *Hydrogen technology*. Springer-Verlag Berlin Heidelberg 2008.
- [22] A. M. Elberry, J. Thakur, A. Santasalo-Aarnio, M. Larmi. Large-scale compressed hydrogen storage as part of renewable electricity storage systems. *International journal of hydrogen energy* 46 (2021) 15671 – 15690
- [23] B. Sunden. Hydrogen, batteries and fuel cells. <https://doi.org/10.1016/C2018-0-01247-5>
- [24] R. Folkson. *Alternative fuels and advanced vehicle technologies for improved environmental performance*. ISBN 978-0-85709-522-0.
- [25] Schulz, R. Huot, J. Liang, G. Boily, S. Van Neste. Structure and hydrogen sorption properties of ball milled Mg dihydride. *Materials Science Forum* (1999), 312, pp. 615-622.
- [26] B. Sakintunaa, F. Lamari-Darkrimb, M. Hirscher. Metal hydride materials for solid hydrogen storage: A review. *International Journal of Hydrogen Energy* 32 (2007) 1121 – 1140
- [27] L. Green, Jr. An Ammonia energy vector for the hydrogen economy. *Int. J. Hydrogen Energy*, Vol. 7, No. 4, pp. 355-359, 1982
- [28] G. Thomas and G. Parks. Potential roles of ammonia in a hydrogen economy. U.S. Department of Energy. <https://www.researchgate.net/publication/331595915>
- [29] A. Klerke, C. H. Christensen, J. K. Nørskov, and T. Vegge. Ammonia for hydrogen storage: challenges and opportunities. *J. Mater. Chem.*, 2008, 18, 2304–2310
- [30] A. C. Dillon, K. M. Jones et al. Storage of hydrogen in single-walled carbon nanotubes. *Nature* I Vol 386127 March 1997.
- [31] S. Orimo, G. Majer et al. Hydrogen in the mechanically prepared nanostructured graphite. *Appl. Phys. Lett.* 75, 3093 (1999)
- [32] J. Chen, S.L. Li, Z.L. Tao. Novel hydrogen storage properties of MoS<sub>2</sub> nanotubes. *Journal of Alloys and Compounds* 356–357 (2003) 413–417
- [33] Jun Chen, Suo-Long Li et al. Titanium Disulfide Nanotubes as Hydrogen-Storage Materials. *J. Am. Chem. Soc.* 2003, 125, 5284-5285
- [34] P. Kumar, S. Singh, S.A.R. Hashmi, Ki-Hyun Kim. MXenes: Emerging 2D materials for hydrogen storage. *Nano Energy* 85 (2021) 105989
- [35] E. Wingner and H. B. Huntington. On the Possibility of a metallic modification of hydrogen. *J. Chem. Phys.* **3**, 764 (1935)
- [36] N. W. Ashcroft. Metallic hydrogen: A high-temperature superconductor? *Physical Review Letters*, Volume 21, Number 26, 23 December 1968.
- [37] P. Loubeyre, F. Occelli & P. Dumas. Synchrotron infrared spectroscopic evidence of the probable transition to metal hydrogen. *Nature*, Vol 577, 30 January 2020

- [38] A. Dewaele, M. Mezouar et al. Toroidal diamond anvil cell for detailed measurements under extreme static pressures. *Nature Communications* (2018) 9:2913
- [39] I. F. Silvera and J. W. Cole. Metallic hydrogen: The most powerful rocket fuel yet to exist. *Journal of Physics Conference Series* 215(1): 012194
- [40] A. Fujishima, K. Honda. Electrochemical photolysis of water at a semiconductor electrode. *nature* 238, 37–38 (1972). <https://doi.org/10.1038/238037a0>
- [41] A. Fujishima, N. Tata, N. Rao, A. Tryk. Donald. Titanium dioxide photocatalysis. *Journal of Photochemistry and Photobiology C: Photochemistry Reviews* 1 (2000) 1–21
- [42] Ak. Kudo and Y. Miseki. Heterogeneous photocatalyst materials for water splitting. *Chem. Soc. Rev.*, 2009, 38, 253–278
- [43] B. Paul, J. Andrews. Optimal coupling of PV arrays to PEM electrolyzers in solar–hydrogen systems for remote area power supply. *International Journal of Hydrogen Energy* 33 (2008) 490 – 498
- [44] J. Lagorse, M. G. Simoes et al. Energy cost analysis of a solar-hydrogen hybrid energy system for stand-alone applications. *International Journal of Hydrogen Energy* 33 (2008) 2871 – 2879
- [45] Jülich scientists report efficiency record for reversible fuel cell. *Fuel Cells Bulletin*, Vol. 2019. pp. 15. [https://doi.org/10.1016/S1464-2859\(19\)30036-7](https://doi.org/10.1016/S1464-2859(19)30036-7)
- [46] Bahman Shabani, John Andrews, Simon Watkins. Energy and cost analysis of a solar-hydrogen combined heat and power system for remote power supply using a computer simulation. *Solar Energy* 84 (2010) 144–155
- [47] Syed Altan Haider, Muhammad Sajid, Saeed Iqbal. Forecasting hydrogen production potential in islamabad from solar energy using water electrolysis. *International Journal of Hydrogen Energy* 46 (2021) 1671 – 1681
- [48] R. Boudries, A. Khellaf, A. Aliane, L. Ihaddaden, F. Khida. PV system design for powering an industrial unit for hydrogen production. *International Journal of Hydrogen Energy* 39 (2014) 15188 – 15195
- [49] A. Szyszka. Demonsration Plant, Neunburg Vorm Wald, Germany, to Investigate and Test Solar-Hydrogen Technology. *J. Hydrogen Energy*, Vol. 17, No. 7, pp. 485-498, 1992
- [50] F.S. Huraib, S.M. Hasnain, and S.H. Alawaji. Lessons Learned from Solar Energy Projects in Saudi Arabia. *Wrec* 1996. Doi: [10.1016/0960-1481\(96\)88480-1](https://doi.org/10.1016/0960-1481(96)88480-1)
- [51] Y. Xiang, X. Zhang et al. Techno-economic design of energy systems for airport electrification: A hydrogen-solar-storage integrated microgrid solution. *Applied Energy* 283 (2021) 116374
- [52] H. Aki, I. Sugimoto, M. Ishida et al. Optimal operation of a photovoltaic generation-powered hydrogen production system at a hydrogen refueling station. *International Journal of Hydrogen Energy* 43 (2018) 14892 – 14904
- [53] J. Hinkley, J. Hayward, R. McNaughton, R. Gillespie. Cost assessment of hydrogen production from PV and electrolysis. *Csiro Energy report*, 21 March 2016.

- [54] U.S. energy Information Administration. Levelized cost of new generation resources in the annual energy outlook 2021.  
[https://www.eia.gov/outlooks/aeo/pdf/electricity\\_generation.pdf](https://www.eia.gov/outlooks/aeo/pdf/electricity_generation.pdf)
- [55] K. Cost, S. Shammugam et al. Levelized cost of electricity Renewable energy technologies. March 2018, Fraunhofer ISE.
- [56] J. Hinkley, J. Hayward et al. Cost assesment hydrogen production from PV and electrolysis. Csiro Energy, 21 march 2016.  
<https://arena.gov.au/assets/2016/05/Assessment-of-the-cost-of-hydrogen-from-PV.pdf>
- [57] L. Bertuccioli, A. Chan et al. Study on development of water electrolysis in the EU. E4tech elementenergy report, February 2014.
- [58] C. Ainscough, D. Peterson, E. Miller. Hydrogen production cost from PEM electrolysis. Department Of Energy, Hydrogen and Fuel Cells Program Record 14004, July 1, 2014.  
[https://www.hydrogen.energy.gov/pdfs/14004\\_h2\\_production\\_cost\\_pem\\_electrolysis.pdf](https://www.hydrogen.energy.gov/pdfs/14004_h2_production_cost_pem_electrolysis.pdf)
- [59] S. Timmerberg, M. Kaltschmitt. Hydrogen from renewables: Supply from north africa to central europe as blend in existing pipelines – Potentials and costs. Applied Energy 237 (2019) 795–809
- [60] D. Yadav, R. Banerjee. A review of solar thermo chemical processes. Renewable and Sustainable Energy Reviews 54 (2016) 497–532
- [61] D. Yadav, R. Banerjee. Economic assessment of hydrogen production from solar driven high-temperature steam electrolysis process. Journal of Cleaner Production 183 (2018) 1131e1155
- [62] Japan Strategic Energy Plan, April 2014. <https://doi.org/10.1155/2017/4107614>
- [63] Australian Power Generation Technology Report. 2015 Electric Power Research Institute, Inc. <https://www.aph.gov.au/DocumentStore.ashx?id=080fc017-86e9-435d-98c9-58dc320c49db>
- [64] G. Parks, R. Boyd, J. Cornish, and R. Remick. Hydrogen Station Compression, Storage, and Dispensing Technical Status and Costs. Technical Report: NREL/BK-6A10-58564, May 2014. <https://www.nrel.gov/docs/fy14osti/58564.pdf>
- [65] S.Z. Zhiznin, V.M. Timokhov, A.L. Gusev. Economic aspects of nuclear and hydrogen energy in the world and Russia. International Journal of Hydrogen Energy 45 (2020) 31353 – 31366
- [66] L.J. Guo, L. Zhao, X.M. Wu et al. Reprint of: Solar hydrogen production and its development in China. Energy 35 (2010) 4421e4438