



TALLINN UNIVERSITY OF TECHNOLOGY
SCHOOL OF ENGINEERING
DEPARTMENT OF MECHANICAL AND INDUSTRIAL ENGINEERING

STANDARDISING FAILURE REPORTING FOR ELECTRONICS

ELEKTROONIKAVIGADE RAPORTEERIMISE SÜSTEEMI STANDARDISEERIMINE

Üliõpilane: Erkki-Siim Lind
/nimi/

Üliõpilaskood 211801MATM

Juhendaja: Martin Eerme, programmijuht
/nimi, amet/

AUTHOR'S DECLARATION

Hereby I declare, that I have written this thesis independently.

No academic degree has been applied for based on this material. All works, major viewpoints and data of the other authors used in this thesis have been referenced.

22. May 2023

Author: signed digitally

/signature /

Thesis is in accordance with terms and requirements

"....." 20....

Supervisor:

/signature/

Accepted for defence

"....."20... .

Chairman of theses defence commission:

/name and signature/

Non-exclusive licence for reproduction and publication of a graduation thesis¹

I, Erkki-Siim Lind (author's name)

1. grant Tallinn University of Technology free licence (non-exclusive licence) for my thesis Standardising failure reporting for electronics (*title of the graduation thesis*) supervised by Martin Eerme (*supervisor's name*)

1.1 to be reproduced for the purposes of preservation and electronic publication of the graduation thesis, incl. to be entered in the digital collection of the library of Tallinn University of Technology until expiry of the term of copyright;

1.2 to be published via the web of Tallinn University of Technology, incl. to be entered in the digital collection of the library of Tallinn University of Technology until expiry of the term of copyright.

2. I am aware that the author also retains the rights specified in clause 1 of the non-exclusive licence.

3. I confirm that granting the non-exclusive licence does not infringe other persons' intellectual property rights, the rights arising from the Personal Data Protection Act or rights arising from other legislation.

22.05.2023

¹ *The non-exclusive licence is not valid during the validity of access restriction indicated in the student's application for restriction on access to the graduation thesis that has been signed by the school's dean, except in case of the university's right to reproduce the thesis for preservation purposes only. If a graduation thesis is based on the joint creative activity of two or more persons and the co-author(s) has/have not granted, by the set deadline, the student defending his/her graduation thesis consent to reproduce and publish the graduation thesis in compliance with clauses 1.1 and 1.2 of the non-exclusive licence, the non-exclusive license shall not be valid for the period.*

DEPARTMENT OF MECHANICAL AND INDUSTRIAL ENGINEERING

THESIS TASK

Student: Erkki-Siim Lind, 211801.....(name, student code)

Study programme, MATM02/18 - Product Development and Production Engineering
(code and title)

main speciality: Production engineering and robotics

Supervisor(s): Head of study programme, Martin Eerme, 6203270 (position, name,
phone)

Consultants:(name, position)

..... (company, phone, e-mail)

Thesis topic:

(in English) Standardising failure reporting for electronics

(in Estonian) Elektroonikavigade raporteerimise süsteemi standardiseerimine

Thesis main objectives:

1. Develop a standard process for failure analysis
2. Define a layout and all necessary equipment for analysis
3. Develop a safe way of testing with high voltage

Thesis tasks and time schedule:

No	Task description	Deadline
1.	Concept creation and process development	01.02.2023
2.	Mechanical and electrical design for electrical inspection workstation	01.04.2023
3.	Finalise documentation	21.05.2023

Language: English **Deadline for submission of thesis:** ".22...".05.....2023a

Student: Erkki-Siim Lind signed digitally ".22"..05.....2023a
/signature/

Supervisor: Martin Eerme ".....".....20....a
/signature/

Consultant: ".....".....20....a
/signature/

Head of study programme: ...Martin Eerme ".....".....20....a
/signature/

Terms of thesis closed defence and/or restricted access conditions to be formulated on
the reverse side

CONTENTS

Preface.....	7
List of abbreviations and symbols.....	8
1. Introduction.....	9
2. Project management.....	11
2.1 Product scope.....	11
2.2 Resources and responsibilities.....	11
2.3 Layout.....	11
2.4 Milestones.....	12
3. Process definition.....	13
3.1 Failure Analysis process.....	13
3.1.1 Data collection and consolidation.....	15
3.1.2 Visual Inspection.....	15
3.1.3 Electrical inspection.....	15
3.1.4 Writing a report.....	16
4. Layout.....	17
4.1 Mechanical and visual inspection workstation.....	17
4.2 Buffer shelves.....	18
4.3 Electrical inspection workstation.....	18
4.4 Process flow.....	18
5. Electrical inspection workstation design.....	20
5.1 Specification.....	20
5.2 Performance Level requirement.....	21
5.2.1 Risk assessment.....	23
5.3 Electrical design.....	24
5.3.1 Electrical block diagram.....	24
5.3.2 Electrical parameters.....	25
5.3.3 Main circuit 400V.....	25
5.3.4 Control circuit.....	25
5.3.5 Electrical schematics.....	26
5.4 Mechanical design.....	27
5.4.1 Lid solution 1: Bi-fold door single.....	27

5.4.2 Lid solution 2: Double hinged fold open door.....	27
5.4.3 Lid solution 3: Enclosure with counterweighted vertical sliding door	28
5.4.4 Door solutions summary	28
5.4.5 Gas spring force calculation.....	29
5.4.6 Final design.....	31
5.4.7 Mechanical drawings	33
5.5 Performance level calculation	33
6. Summary.....	35
7. Kokkuvõte.....	36
8. References.....	37
Appendices	38
Appendix 1 Tools for mechanical and visual workstation	39
Appendix 2 Tools and equipment for electrical inspection workstation	41
Appendix 3 Mechanical drawings for electrical inspection workstation	43
Appendix 4 Electrical schematics for electrical inspection workstation.....	57

PREFACE

The author aims to prove that by standardising and clearly defining electronics failure analyse process can result in processing large quantity of products and therefore creating better transparency on failure modes and failed components statistics. This in addition creates more efficient and value adding work for engineers working on root cause analysis where the input for their work will come from the failure report. By standardising the process, it allows also to eliminate the need to have high competence workers for standardised work. In addition to developing a process this thesis will also include developing an electrical inspection workstation along with other necessary equipment and tools needed for a well-defined concept which could be implemented in real life. The author would like to thank Indrek Jürs and Priit Reim for mentoring the author in different categories and would also like to thank supervisor Martin Eerme and many of author's colleagues who supported and helped one way or another.

Keywords: analysis, process, tester, safety

LIST OF ABBREVIATIONS AND SYMBOLS

PCBA – Printed Circuit Board Assembly

FA – Failure Analysis

FR – Failure Reporting

CA – Component Analysis

PL – Performance Level

PC - Polycarbonate

BNC - Bayonet Neill–Concelman

EUT – Equipment Under Test

ISO - International Organization for Standardization

AC – Alternating Current

DC – Direct Current

PFH_D - Probability of dangerous failure per hour

1.INTRODUCTION

Electronics are essential in our daily lives, powering various devices such as smartphones and airplanes. However, these electronics are not perfect and can fail for a variety of reasons, such as defects or wear and tear over time. Electronics failures can range from minor inconveniences to potentially catastrophic outcomes, such as injury or loss of life. For example, a critical system failure in a plane or a medical device could have dire consequences.

Therefore, there is a need to analyse electronics failures to determine the root cause of the problem and prevent it from happening again. Failure analysis involves examining the physical, chemical, and electrical properties of the failed device or component, as well as the circumstances surrounding the failure.

By conducting failure analysis, engineers and manufacturers can gain valuable insights into the reliability of their products and make improvements to prevent failures in the future. This leads to greater customer satisfaction, lower costs, and increased safety. In a competitive market where the reliability of products plays a significant role in customer satisfaction then having a full transparency on all product failures can help detect early warning signs or patterns which might lead to future catastrophic failures

In a high-volume manufacturing company, the likelihood of encountering a substantial number of failures increases significantly. This means that such company might have the need to analyse large quantities of failures. A large portion of failures might be perhaps minor and do not cause any significant financial loss but in a competitive market where the reliability of products plays a significant role in customer satisfaction then having a full transparency on all product failures is necessary to detect early warning signs or patterns which might lead to future catastrophic failures. This is where the need for this thesis topic comes. To have the capability to analyse large number of failed products which analysed data would provide useful information for failure analysis engineers to help recognizing failure patterns and therefore narrow the focus on which problems need to be dealt with in deeper level investigation. As the goals is to standardise a process then this concept can utilise workers with not high level of competence in electronics which would help engineers to focus their time on more complex analyses.

This thesis is made for one specific company only and all the aspects in this concept are based on this company's way of operating. Therefore, this concept might not be applicable for other companies out there.

The scope of this topic covers all aspects of developing a manufacturing concept process such as project management, process and tester development, risk assessment and even including all necessary tools and equipment. The output of this thesis will give all information needed to build and implement this concept in real life. In this thesis not all aspects of this concept will be mentioned in detail to protect some of the company's confidential information but which the company is aware themselves. This approach enables this thesis to be published publicly. This study will also try to estimate the cost for this concept after which it will be decided how this concept will be executed.

2.PROJECT MANAGEMENT

The concept will be developed as a project. The objective of this project is to create a standardised process and provide the necessary tools and equipment for at least one person to produce failure reports for products that require analysis. The thesis will also discuss the project's scope, schedule and resources required for successful completion. Effective project management is critical to ensuring that the project is delivered on time and meets the company's objectives.

2.1 Product scope

This concept is primarily focused on the analysis of printed circuit board assemblies (PCBA-s) or products that contain PCBA-s. However, it is important to note that the main goal of this thesis is to standardise the failure analysis process for any product, and therefore, the specific PCBA or product that will be analysed in this concept is not of great significance.

2.2 Resources and responsibilities

The author himself is the official only resource for project managing and engineering of this project. Responsibilities include both leading the project and develop any engineering solution required to make this project.

2.3 Layout

The designated area for this concept's development is 38.3 m² as shown below in Figure 2.1, which is sufficient to accommodate at least one person working full-time and the necessary equipment for analysis.

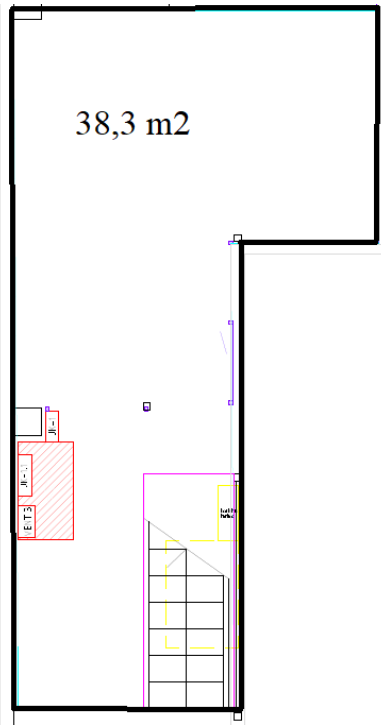

Figure 2.1 Area layout

2.4 Milestones

To better plan the project and to divide the load then a Gantt chart was created to illustrate project schedule and to set certain goals.

Task Name	2023						
	January	February	March	April	May	June	July
Project planning and getting approvals	■	■					
Process development		■	■				
Workstations defined			■				
Electrical inspection design			■	■	■		
Documentation completed				■	■		
Ordering of materials						■	
First analyse performed							■

Figure 2.2 Gantt chart of project timeline

3.PROCESS DEFINITION

One of the objectives of this concept is to standardise the failure analysis process as much as possible. To achieve this, the failure analysis process will be examined to identify areas that can be standardised. The process will be defined by identifying the key steps involved in failure analysis.

3.1 Failure Analysis process

Failure Analysis (FA) process is described in Figure 3.1. FA Process produces information about the location of the failure, what was the failure mode, what was the stressor and was the failure caused by overstress or wear out.

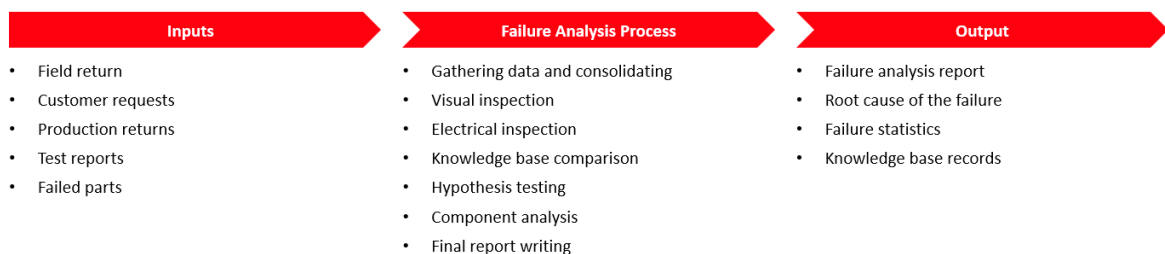

Figure 3.1 Failure analysis process

The Failure Analysis process can be divided into three main steps. The first step is Failure Reporting (FR), which describes the failed component (such as resistor or capacitor) and the failure mode (such as shorted or open circuit). In this step, only non-destructive methods are used to preserve evidence for deeper analysis. The second step is Failure Analysis (FA), which investigates why the product assembly failed but does not determine the root cause of the failed component. The final step is Component Analysis (CA), which focuses on identifying the root cause of the component failure. In a simplified matter the questions that need to be answered in each step are described in Table 3.1

Table 3.1 Failure analysis process questions

Failure report	Failure analysis	Component analysis
<ul style="list-style-type: none"> • Which product failed or malfunctioned? • When did the failure occur? • Who or what was impacted by the failure? • What specifically happened during the failure event? • Which component or system failed? • What was the failure mode or how did the failure occur? 	<ul style="list-style-type: none"> • Why the product assembly failed? • Were the thermal & electrical stresses within component specification? • Why product assembly failed? • Where the thermal & electrical stresses within component specs? • Nominal or defective product/assembly • Statistical analysis • Origin of the defect stress 	<ul style="list-style-type: none"> • What caused the component to fail or malfunction? • What were the factors that contributed to the failure? • Was it due to over-stress or wear and tear? • Was the product defective or functioning normally within its nominal range?

Failure Reporting will be the focus for this concept because the methods and processes to achieve a failure report can be standardised which enable to analyse large quantity of failures in a fast and effective way. In addition to that, the other reason for choosing to do only failure reporting is that this would not require high level of expertise. This means that it easier to find workers who could perform such standard analyses. Failure Analyse and Component Analyse require deeper analyse which are case specific, can take a lot of time to solve and require higher level competence to perform due to the complexity of problem. Single failures may be difficult to identify the root cause and first incidents may not justify allocating resources for deeper analysis. Therefore, there is a need to analyse large amounts of failures to justify allocating resources and choosing the right focus of deeper analysis.

To answer the questions required in failure reporting then following step must be done in the process:

- Data collection and consolidation
- Visual inspection
- Electrical inspection
- Writing a report

In the next chapter, these processes will be handled in more detail.

3.1.1 Data collection and consolidation

The first step of Failure Report is to gather all the relevant data regarding the failed product, including the customer complaint, service report and other relevant information about the product like the serial number. This information is necessary for statistical purposes as well as to know the history of product which might be required in failure or component analysis.

3.1.2 Visual Inspection

Once the preliminary data is gathered, the next step is to perform a visual inspection of the failed product. This involves examining the product for any visible defects, such as cracks, burn marks, or other physical damage. A microscope may be used to examine the product surface and identify any potential causes of the failure. Inspected product must be documented by making pictures of relevant findings and/or overall condition of the product.

3.1.3 Electrical inspection

Next step is to perform electrical inspection to the product to determine if it is operating correctly. Before starting functional test of the product then products are first inspected with a multimeter to assure that there are no short circuits present on the product which could destroy evidence. A standard procedure document is made by the company for every specific product stating how and what should be checked always before applying voltage on the product. Functional test involves running the product through a series of tests to check its functionality, such as power-on self-test, communication checks, and other tests that are specific to the product function. This step might not be performed if previous inspections determine that functional testing could harm the product which could result in destroying evidence.

3.1.4 Writing a report

The last step is to write a report. Report is written on a standard template, and it includes a summary of the findings, analyse and all necessary information about the product. Having a structured and clear report is key to having organised data which can be processed and categorised. In this case the report template would be used is company's internal document which is not publicly available.

4.LAYOUT

As the process is defined then it is possible to start planning the layout for this concept. Workstations are tables dedicated for certain work to be performed on them. The usage and number of workstations is determined by actions done in the area. The quantity of workstations is assumed for at least 1 person but better would be if 2 persons can work there simultaneously. It was decided also that all workstations will have 1800x700 mm tabletop for comfortable working.

Although first part of the process is to collect data and the last part is to write a report but since laptop is provided to every worker in the company where this concept is implemented then the data collection and writing a final report can be done on any workstation therefore a separate workstation for documenting will not be made.

4.1 Mechanical and visual inspection workstation

Mechanical inspection workstation is meant for all kinds of disassembly, modifications or preparing test setup for electrical inspection necessary to perform analysis. For this purpose, the workstation must include variety of tools which could be used. A full set of mechanical tools needed for this table would cost around 1600 euros for one workstation. A full list of tools required in this workstation can be found in Appendix 1. The cost of workstation is around 2000 euros for one workstation.

As visual inspection requires only a microscope or magnifying glass then it would make sense to put these on the same table as mechanical tools are. Close-up images are recorded by taking a picture. A 10 to 70 times magnification digital microscope and a magnifying glass is estimated to cost around 1200 euros. Both are listed in Appendix 1.



Figure 4.1 Example of mechanical & visual inspection workstation [1]

4.2 Buffer shelves

For storing all products that need to be analysed there will be a dedicated buffer shelf for this. This shelf should be capable of storing different size products and at least 3 days' worth of analyses which is why there will be 2 shelves used. Such shelves are modular and can be combined if more storage is needed. In addition to storing incoming analyses, there will be another shelf dedicated to finished analyses. The cost of buffer shelves is approximately 1200 euros.

4.3 Electrical inspection workstation

This workstation will be handled separately in Paragraph 5. The tools needed in this workstation can be found in Appendix 2. The cost of the tools needed in this workstation is estimated to be around 1688 euros. The cost of design will be evaluated later in the design paragraph.

4.4 Process flow

A simple process flow has been described in Figure 4.3 showing how previously described failure reporting process is done. In the planned layout showed in Figure 4.2 the red marked area is separated from the other part of the production with an industrial guardfence. This is for safety purposes since in that red area electrical tests are being performed and therefore workers who do not have proper training and knowledge of electrical safety should not be able to access that area. Outside of the area there is dedicated area for rocla and euro pallet which is used for transporting incoming and outgoing material into the area.

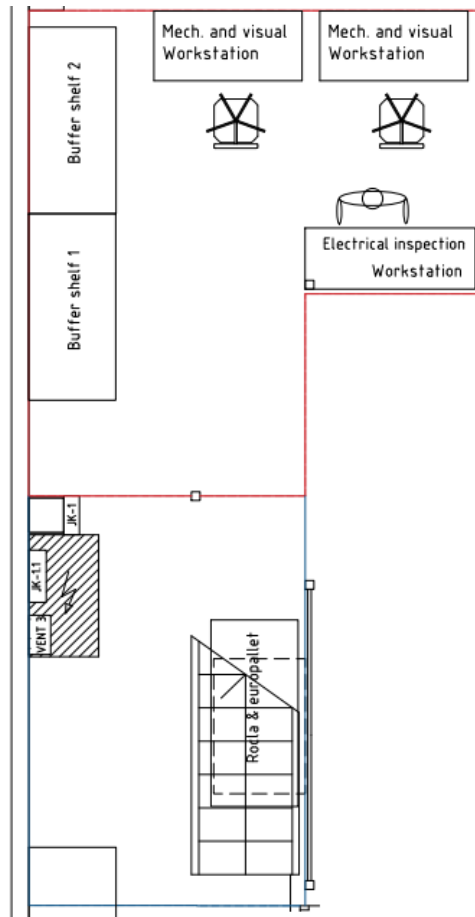

Figure 4.2 Planned layout

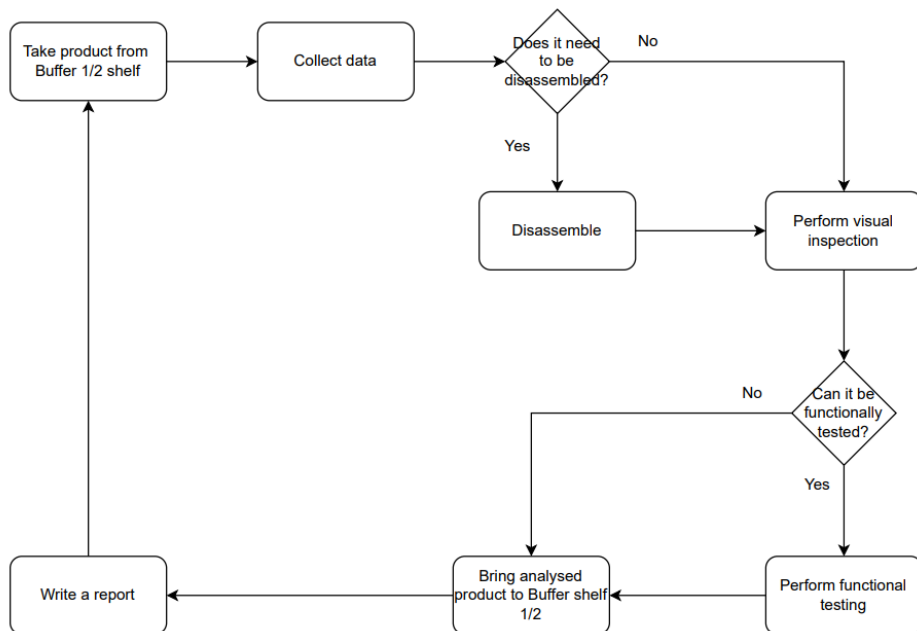

Figure 4.3 Process flow

5. ELECTRICAL INSPECTION WORKSTATION DESIGN

In this workstation electricity is applied to product or PCBA therefore testing must be carried out safely. Before any decision on design can be made a specification must be made to understand what requirements must be filled.

5.1 Specification

These requirements mentioned in Table 5.1 will define what conditions must the electrical inspection workstation meet in design and application. These requirements were set by the company given their safety rules and wishes for the electrical inspection workstation.

Table 5.1 Requirements for electrical inspection workstation

Nr	Requirement	Comment
1.	Determine minimum required PL level and achieve the minimum requirement	EN ISO 13849-1 standard
2.	Must have at least 8 holes for measurement device cables to be inserted but not more than 29 mm in diameter. Holes must be covered with rubber cable lugs.	29 mm requirement is for BNC connectors.
3.	Tabletop area for testing must be 1800x700 mm	
4.	Workstation maximum dimensions must not be more than: <ul style="list-style-type: none"> • 1900 mm in width • 1000 mm in length • 2500 mm in height 	To fit in the area
5.	Workstation must have ventilation holes	

5.2 Performance Level requirement

PL (Performance Level) is a technology-neutral concept that can be used for electrical, mechanical, pneumatic and hydraulic safety solutions. PL is a measure of the reliability of a safety function. PL is divided into five levels (a-e). PL e gives the best reliability and is equivalent to that required at the highest level of risk [2]. PL is based on EN ISO 13849-1 standard which provides safety requirements and guidance on safety of machinery.

Table 5.2 PL levels [3]

Performance Level (PL)	Probability of Dangerous Failure per Hour (PFHd) 1/h
a	$\geq 10^{-5}$ and $< 10^{-4}$ (0.001% to 0.01%)
b	$\geq 3 \times 10^{-6}$ and $< 10^{-5}$ (0.0003% to 0.001%)
c	$\geq 10^{-6}$ and $< 3 \times 10^{-6}$ (0.0001% to 0.0003%)
d	$\geq 10^{-7}$ and $< 10^{-6}$ (0.00001% to 0.0001%)
e	$\geq 10^{-8}$ and $< 10^{-7}$ (0.000001% to 0.00001%)

The process of determining required PL level and establishing it can be described in Figure 5.1

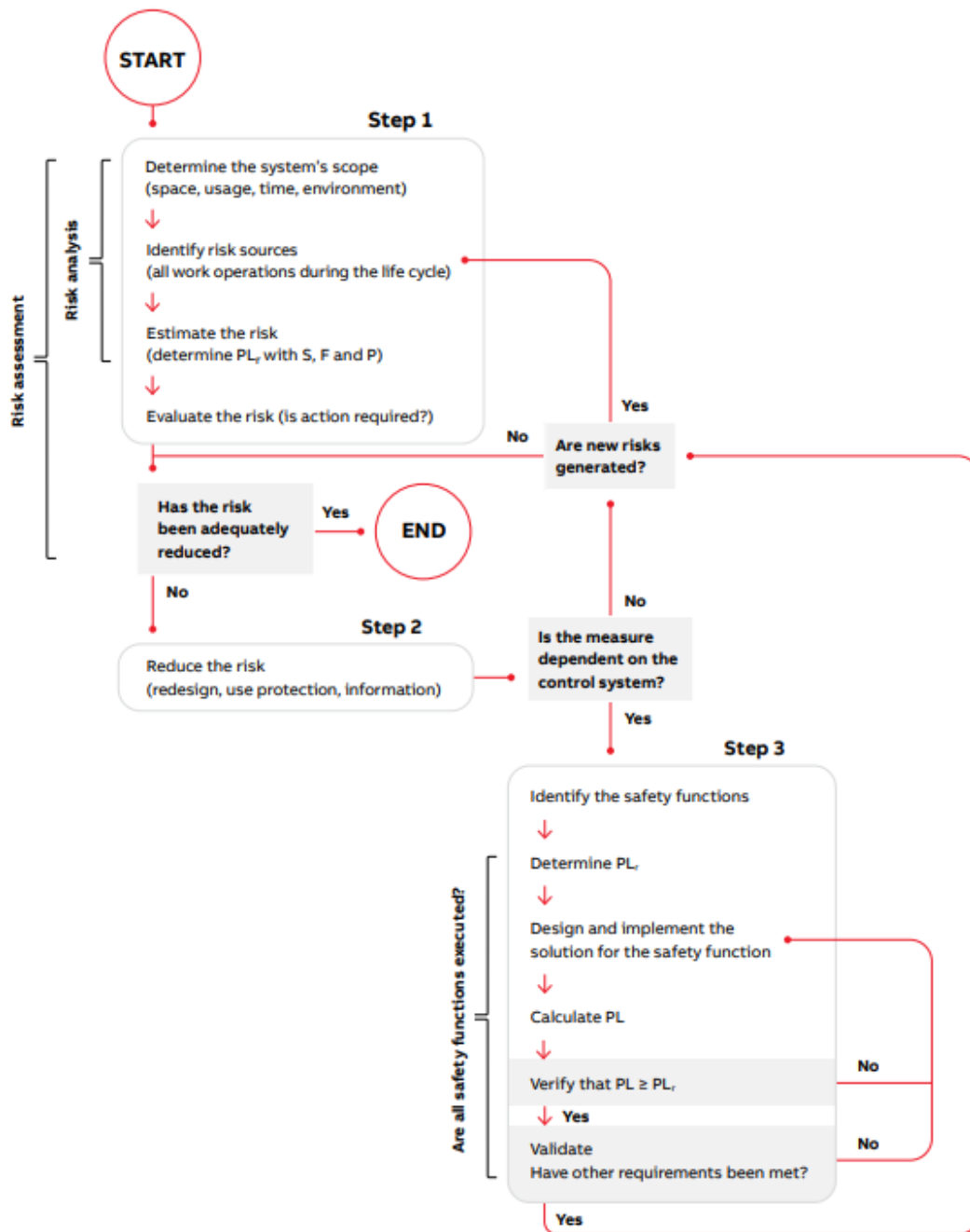

Figure 5.1 Performance Level process [2]

5.2.1 Risk assessment

This risk assessment is based on EN ISO 12100:2010 standard which stipulates the requirements for a risk assessment. It is this that EN ISO 13849-1 is based on, and a completed risk assessment is a prerequisite for being able to work with the standard.

On electrical inspection workstation the first step is preparation which means preparing an equipment under test (EUT) on it. The preparation includes activities such as connecting measurement devices, probes and connecting to a power supply. Once the preparation is finished then electrical testing is started by applying voltage to the test setup. After testing the power supply is disconnected and all connections disconnected. The workstation will be intended to have mechanical and electrical design safety measures. This means that workstation can only be operated if safety lid is covering the EUT and interlock locks the safety lid making it impossible to touch any live parts of the workstation during operation. Safety lid can only be opened when interlock is reset which disconnects voltage in workstation. As an additional administrative measure, all EUT-s must be first checked for voltage with a voltage detector before being allowed to touch any part of the EUT with a hand.

Since there is electricity higher than 50V AC present in the workstation then the severity of injury can be serious (S2). The workstation is expected to be operated in one shift (8 hours per shift) 365 days a year. A total access to the danger zone is estimated to be four times per hour (F2), including any kind preparation needed to set up EUT. As there will be mechanical and electrical protective measures applied on the workstation then the operator has the possibility of avoiding hazard or limiting harm (P1).

The assessment for the safety function required for access to the workstation is $PL_r = d$ (S2, F2,P1). In addition to this safety function, an emergency stop function is needed which is also assessed as $PL_r = d$.

S	Severity of injury
S1	slight (normally reversible injury)
S2	serious (normally irreversible injury or death)
F	Frequency and/or exposure to hazard
F1	seldom to less often and/or exposure time is short
F2	frequent to continuous and/or exposure time is long
P	Possibility of avoiding hazard or limiting harm
P1	possible under specific conditions
P2	scarcely possible

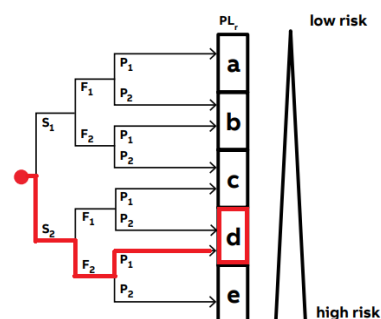

Figure 5.2 PL risk factors levels [2]

Figure 5.3 Required PL for the workstation

5.3 Electrical design

To fill the PL_d requirement of workstation then certain electrical safety measures must be incorporated to design. Easiest way to comply with the standard is to use components with pre-calculated PL and PFH_D values. The goal of the electrical design is to eliminate the possibility of voltage being present when the safety lid is in open position and accessible to the operator. The total cost for all electrical components is approximately 2100 euros.

5.3.1 Electrical block diagram

The supply voltage will be 3 phase 400V AC that is necessary for the main power supply. Contactors as well as interlock are controlled by safety relay. The interlock was chosen to add additional safety measures for this design and the use of interlock is known inside the company also. If the safety lid is locked by the interlock only then it is possible to turn on the power supply, making it impossible for the user to harm themselves when turning on the power supply. Pushbuttons operate with 24V DC with added emergency stop as a required safety feature. Circuit breakers are protective devices for any electrical circuit.

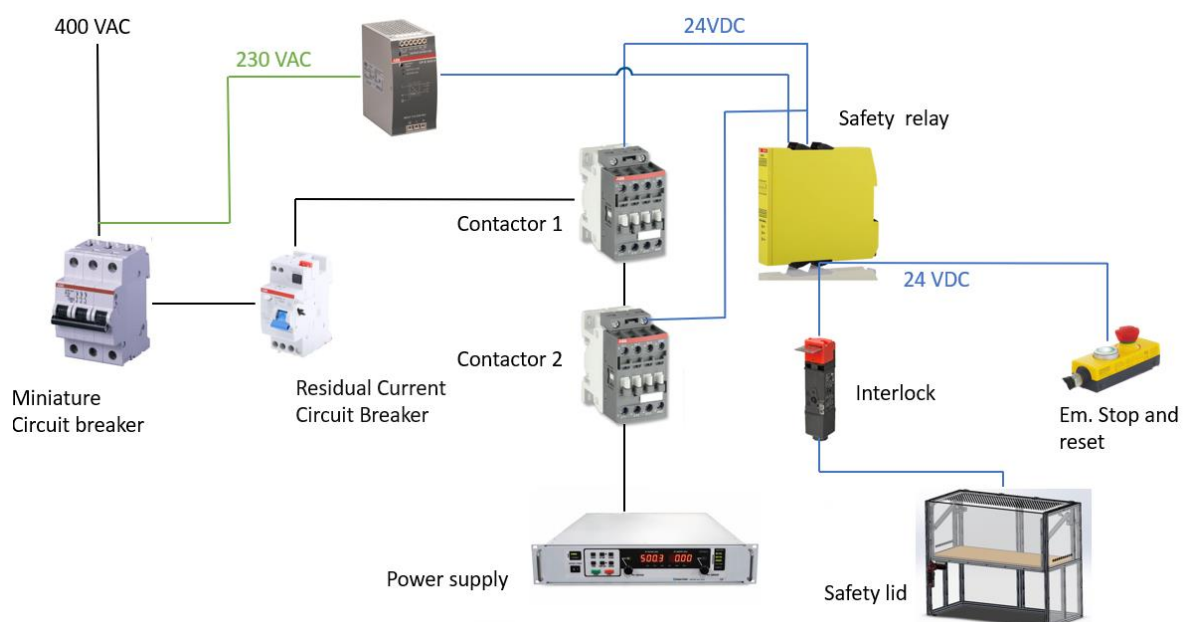

Figure 5.4 Electrical block diagram

5.3.2 Electrical parameters

In below table the parameters for electrical schematic are mentioned

Table 5.3 General electrical parameters

Parameter	Value	Parameter	Value
Power circuit	400V AC	I _n	29A
Control circuit	24V DC	I _n	6A

5.3.3 Main circuit 400V

The main circuit is dimensioned according to power supply that will be used in this workstation. Since the power supply is rated for 29A then around this other component were selected. For safety purposes there is used 2 contactors connected in series. This is because if one contactor should fail due to melted contacts then second contactor could prevent a potential hazard. The probability of 2 contactors failing at the same time is low enough that it should not raise concern. For cable cross-section a 6 mm² would be requirement for nominal current of 29A.

Table 5.4 Main circuit component list

Marking	Component	Manufacturer, product code
-F2	Miniature Circuit Breaker (MCB)	ABB, S203MT-C32
-Q1	Residual Current Circuit Breaker (RCCB)	ABB, IN FH202 40A-30mA/AC
-QA1	Contactors	ABB, AF09Z-30-10-21
-QA2		
-U1	Programmable DC power supply	Magna-Power
-T1	SMPS 230VAC-24VDC	ABB, CP-E 24/5.0

5.3.4 Control circuit

For control circuit to comply with PL_d requirement one solution was found which consisted of safety relay used with interlock and slide lock. By using the same components this solution offers safety level of PL_d which is required.

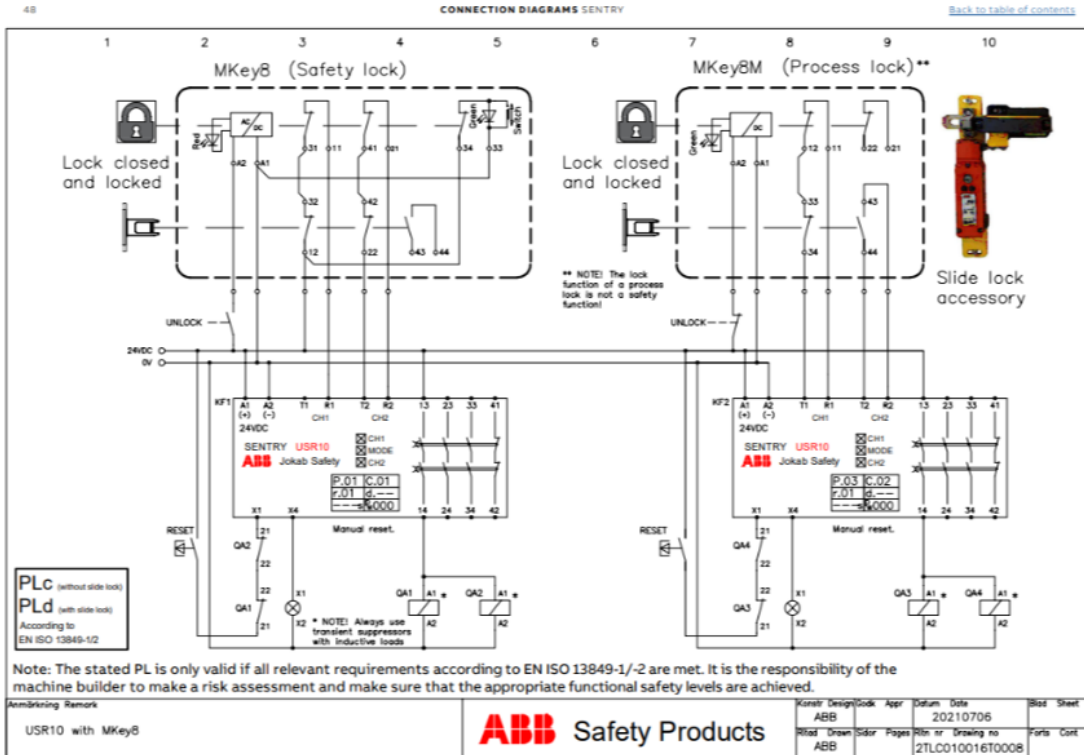

Figure 5.5 Control circuit UR10 with MKey8 (process lock) [9]

The components for control circuit are shown in Table 5.5

Table 5.5 Control circuit component list

Marking	Component	Manufacturer, product code
-KF1	Safety relay	USR10 Sentry
-B1	MKey8M (interlock)	ABB, MKey8M
-S1	Emergency stop button	ABB, Smile 10 EA
-S3	Reset button	ABB, KPR1-101W

5.3.5 Electrical schematics

All relevant schematics are brought out in Appendix 4.

5.4 Mechanical design

From a mechanical design perspective, the primary safety consideration is to prevent unsafe access to the EUT (Equipment Under Test). To achieve this, the workstation must incorporate a protective frame that covers all live parts, ensuring that they cannot be touched when voltage is applied. Alongside safety considerations, it was also important to create a design that could be adapted for use on other workstations where electrical testing is performed on workbenches, which led to specific dimensional requirements for the design. While flexibility for customization was preferred, it was not deemed an essential requirement.

Market research was done first but there was not anything that would be close to requirements set and therefore the focus of market research was put more on the different sort of mechanisms that are available and could be adapted for this workstation.

5.4.1 Lid solution 1: Bi-fold door single

In this solution the protective door is made of 2 pieces and opens to side and folds together when sliding the door.

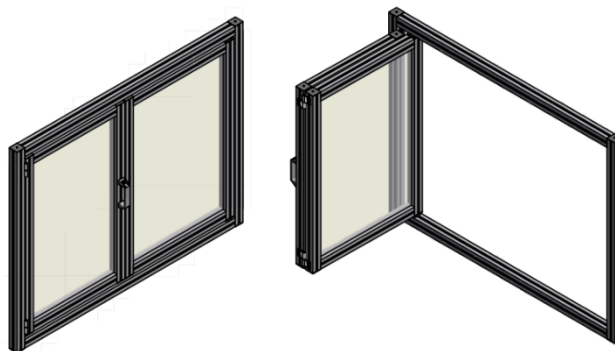

Figure 5.6 Bi-fold door [4]

5.4.2 Lid solution 2: Double hinged fold open door

This solution has vertical bi-fold door that opens and retracts back by using gas springs, giving operator unrestricted access to the inside of the enclosure. Often used as a lathe enclosure.



Figure 5.7 Double hinged fold open door in closed position [5]



Figure 5.8 Double hinged fold open door in open position [6]

5.4.3 Lid solution 3: Enclosure with counterweighted vertical sliding door

Door is connected to the counterweight with roller chain. Vertical door is counterbalanced to stay in the open position.



Figure 5.9 Enclosure with Counterweighted Vertical Sliding Door [7]

5.4.4 Door solutions summary

Given the circumstances and after making a comparison on all solutions with given criteria then door solution 2 seems to be the best solution for this design. However, this would have to be adjusted and designed according to fit the requirements mentioned in Table 5.1.

Table 5.6 Comparison for different tables

	Solution 1	Solution 2	Solution 3
Design simplicity	4	3	3
Low maintenance	4	4	2
Accessibility	1	3	3
Low cost	4	3	2
Company preference	2	4	3
TOTAL:	15	18	14

5 - Excellent

1 - Bad

As "Solution 2" turned out to be the best option out of these then such design will be taken as an example and tried to be fit for the requirements. The main components for this concept would be gas spring and aluminium profile frame which will be covered with polycarbonate to protect the user if anything under the lid should go wrong.

5.4.5 Gas spring force calculation

For opening and closing of the door a gas spring was chosen. To find the correct gas spring, there needs to be found the correct force for spring. As author has experience with Lesjöfors gas springs then this manufacturer was selected.

From the gas spring manufacturer's site [10], a formula (5.1) for simpler cases of calculating force was found:

$$F_1 = \frac{G \times L}{W \times n} + (10 \dots 15\%) = \frac{(33 \times 9,81) \times 275}{55 \times 2} = 809,33 + 10\% = 890,26 \text{ N (5.1)}$$

VARIABLE DESCRIPTION:

F₁ - Gas spring force in Newton

G - Gravitational pull in Newton of the moving part

C - Connection point on the moving part

D - Connection point on the fixed part

E - Swivel point

S - Centre of gravity

L - Horizontal distance from E to S in open position

W - Smallest distance to E

n - Number of gas springs

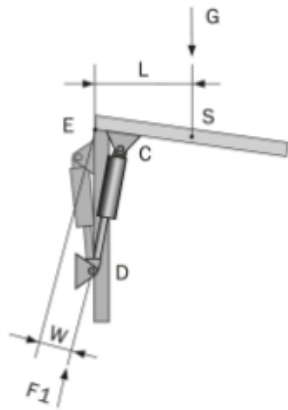

Figure 5.10 Force calculations of gas springs [10]

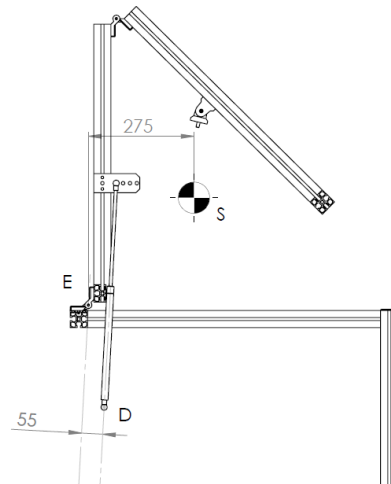

Figure 5.11 Dimensions for calculating gas spring force

A 10% margin of error was used in the formula because of author's own experience that 10% is enough. The calculation shows that the force required for gas spring should be 890,26 N. The closest spring which would satisfy this condition would be 900N spring. From Lesjöfors catalogue spring 9229: 22-10 E 548-250-900N was selected for this application.

9229: 22-10 E 548-250-900N

Conventional gas spring with extension speed 0,1 m/s - 0,3 m/s

FIELDS OF APPLICATION

Lesjöfors gas springs are usually used for lifting and unloading, but their special spring and dampening characteristics mean that the number of applications in which they may be used is quite extensive.

All dimensions are in mm

L = Length +/- 2

B = Stroke

F1 = Spring force in Newtons

Ø1 = Diameter tube

Ø2 = Diameter piston rod

Force range: 15-2000 Newtons

T = Threads

1 kp = 9,80665 Newtons, 1 Newton = 0,10197 kp

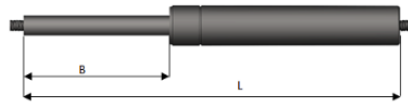

Dimensions och characteristics

Sku	9229
L1	548
B	250
F1	900
Thread type	M
Thread Ø	8

Figure 5.12 Gas spring dimensions [8]

5.4.6 Final design

The final design can be seen in closed position on Figure 5.13 and in open position on Figure 5.14. In closed position the maximum dimensions are 1900 x 948 x 1573 mm and in open position 1900 x 948 x 2343 mm along with a 1800x700 tabletop which fulfils the previously set requirement. The final assembly consists of mainly of three sub-assemblies:

- outer frame;
- inner frame;
- electrical enclosure.

Both frames are made of aluminium profile which gives high flexibility in customisation, easy to assemble and light weight. The frames are covered with 5mm thick polycarbonate which protects the user from being able to touch any live parts under the lid as well as protection if the EUT or any part of it should explode.

The required cable holes can be seen on the right side of the tester. These holes will be covered with rubber cable lead throughs. This protects the cables from rubbing against polycarbonate. Also, the tabletop has been covered with electrically isolating mat. This creates isolating surface which increases the safety of this tester. The whole frame will be grounded.

The electrical enclosure will consist of all the electrical components which were mentioned in electrical design. This enclosure will be modified from a standard enclosure by drilling holes for either mounting or cables.

The cost of the mechanical design is approximately 3600 euros.



Figure 5.13 Final design (closed position)

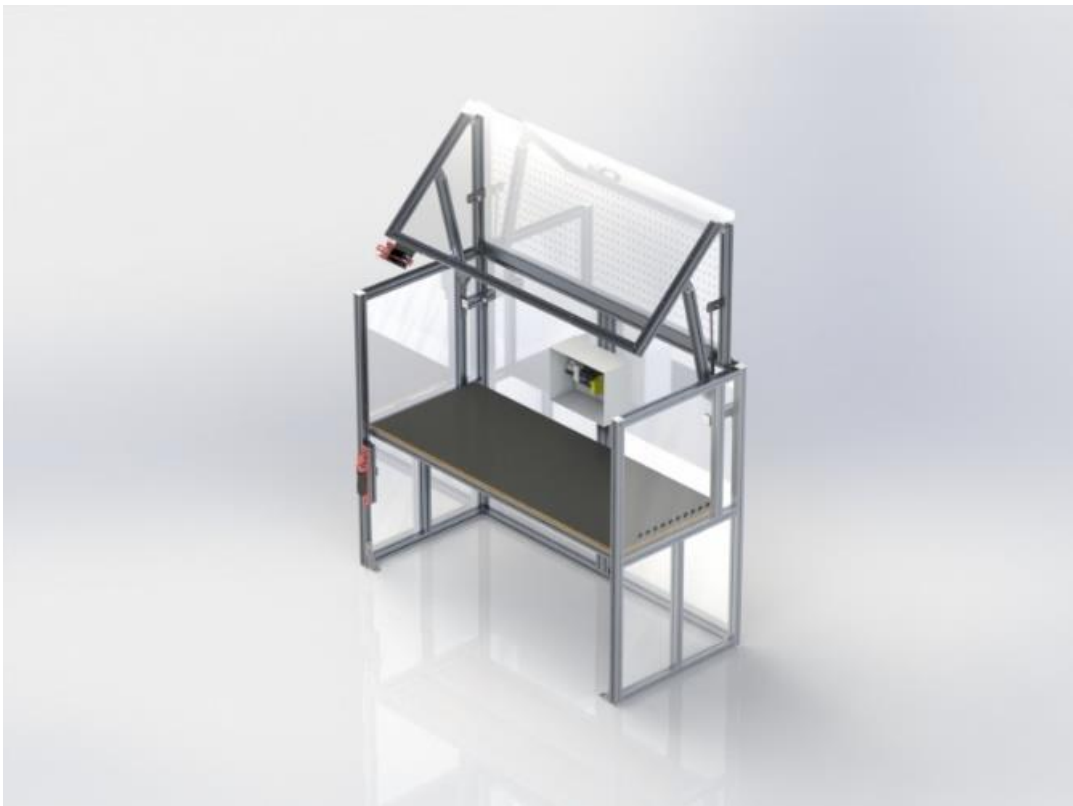

Figure 5.14 Final design (open position)

5.4.7 Mechanical drawings

All mechanical drawings can be found in Appendix 3.

5.5 Performance level calculation

Now that all mechanical and electrical design solutions have been implemented to fulfil PL_d requirement then the PL level of this workstation can be calculated to verify if $PL \geq PL_r$. All PFH_D values to calculate the PL value were found in product technical data sheets and also the formula to calculate [2]. The formula (5.2) to calculating PL:

$$PL_d = S1 (Em. stop (PFHD)) + B1 [MKey8M (PFHD)] + KF1 [USR10 (PFHD)] + Q1/Q2 (contactors PFHD) \quad (5.2)$$

$$PL_d = 1,69 \times 10^{-9} + 3,44 \times 10^{-8} + 4,9 \times 10^{-9} + 2,47 \times 10^{-8} = 6,57 \times 10^{-8} \rightarrow PL_e$$

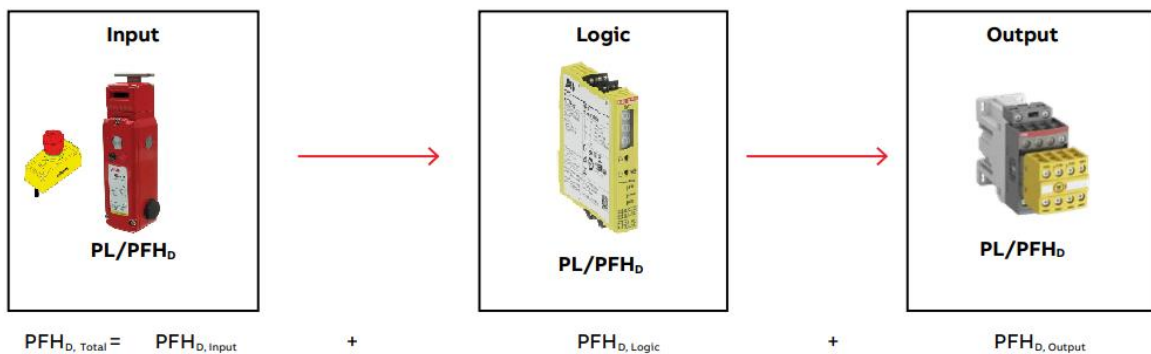

Figure 5.15 Performance level calculation illustration

This calculation shows that this design exceeds the PL requirement with the results of PL_e and as there are mechanical protective measure then all possible risks are adequately reduced making this workstation safe to use and matching to EN ISO 13849-1 - Safety of machinery standard.

Additional risk assessment was undertaken for all activities and possible hazards and in Table 5.7 shows all hazards and control measures which reduce the risk.

Table 5.7 All possible hazards and control measures for electrical inspection workstation usage

Hazards (reason and likely consequence)	Control Measures
<p>Electrical hazard - When preparing test setup for testing then voltage can still be present if power supply has not been switched off and therefore person can get electrocuted.</p>	<p>Engineering design:</p> <ul style="list-style-type: none"> • Lid is covered with polycarbide which protects worker • Emergency stop button disables power supply <p>Equipment:</p> <ul style="list-style-type: none"> • Personal protective equipment (gloves, electrical safety jacket) <p>Administrative:</p> <ul style="list-style-type: none"> • Workers are instructed to check EUT for any faults before testing
<p>Electrical hazard - Faulty EUT can cause arcing/fire. Person can get electric shock or EUT might be caught on fire.</p>	<p>Engineering design:</p> <ul style="list-style-type: none"> • Lid is covered with polycarbide which protects worker • Emergency stop button disables power supply <p>Equipment:</p> <ul style="list-style-type: none"> • Personal protective equipment (gloves, electrical safety jacket) <p>Administrative:</p> <ul style="list-style-type: none"> • Workers are instructed to check EUT for any faults before testing
<p>Electrical hazard - Worker can touch any live part of EUT which can cause electric shock.</p>	<p>Engineering design:</p> <ul style="list-style-type: none"> • Open interlock disables any possibility to have closed circuit and only way to prepare is to open a lid which keeps interlock opened. • Interlock locks the lid from being opened when voltage is present. • PC covers protect from being able to touch. <p>Equipment:</p> <ul style="list-style-type: none"> • Personal protective equipment (gloves, electrical safety jacket) <p>Administrative:</p> <ul style="list-style-type: none"> • Workers are instructed to use the tester and trained in electrical safety
<p>Electrical hazard - Worker can touch any live part of EUT which can cause electric shock.</p>	<p>Engineering design:</p> <ul style="list-style-type: none"> • Open interlock disables any possibility to have closed circuit and only way to prepare is to open a lid which keeps interlock opened. • Interlock locks the lid from being opened when voltage is present. • PC covers protect from being able to touch. <p>Equipment:</p> <ul style="list-style-type: none"> • Personal protective equipment (gloves, electrical safety jacket) • Voltage detectors <p>Administrative:</p> <ul style="list-style-type: none"> • Workers are instructed to use the tester and trained in electrical safety • Voltage detectors are mandatory to use to confirm no voltage is present when touching DUT after testing.

6.SUMMARY

The goal of this thesis was to standardise failure reporting for electronics by developing a new conceptual framework which would enable a manufacturing company to collect data in large quantities about their failed products. The output of this work resulted in ready-made project which could be implemented in the company that requested it. As the concept has not yet been implemented then there is not yet proof how effective this is and improvements could be made.

Failure reporting is one part of failure analysis process that was possible to standardise, and it consists of non-destructive analyse methods such as data consolidation, visual inspection, and electrical inspection where applicable. This analysed information will be valuable for failure analysis engineers to get full transparency on product failures which in addition helps to make data driven decisions on which failures should be analysed deeper.

This concept is utilised on 38,2 m² area and is intended for 2 people to work. It consists of mechanical, visual and electrical inspection workstations with 2 shelves. Mechanical and visual workstations were combined as that would utilise the workstation more efficiently. Electrical inspection workstation required to be in accordance to EN ISO 13849-1 standard which determined that the performance level of this workstation must be PL_d. The mechanical design of this workstation focuses from safety aspect constraining the worker from being able to physically touch any live parts as well as designing how the lid opening and closing mechanism. The lid is being moved by gas springs which holds the lid in opened and closed position. The electrical design contributes to safety with the use of electrical safety components which are with precalculated PL values and which only allow the user to apply voltage when the lid is closed and locked. This eliminates the possibility of person getting electrocuted when not following correct safety procedures. Performance level calculation showed that this workstation exceeds the minimum requirement by achieving PL_e which makes the electrical inspection workstation safe to operate and comply with EN ISO 13849-1 standard.

It was estimated that the whole concept would cost 15 388 euros. The largest part of that cost is the electrical inspection workstation. It is possible to leave some features out which would not affect efficiency drastically and would lower the cost a bit but generally the approximate cost will stay in that range.

7.KOKKUVÕTE

Käesoleva lõputöö eesmärk oli standardiseerida elektroonikaseadmete vigade raporteerimist, töötades välja uue kontseptuaalse raamistiku, mis võimaldaks tootmisettevõttel analüüsida suures koguses andmeid toodete kohta, mis ei vastanud nõuetele. Selle töö tulemuseks valmis projekt, mida saab rakendada seda taotlenud ettevõttes. Kuna kontseptsiooni ei ole veel rakendatud, siis ei ole veel tõestatud, kui tõhus see on, ning mida saaks selle juures veel täiustada.

Vigade raporteerimine on üks osa veaanalüüsiprotsessist, mida oli võimalik standardiseerida, ja see koosneb mittehävitavatest analüüsimeetoditest, nagu andmete konsolideerimine, visuaalne kontroll ja vajaduse korral elektriline kontroll ehk funktsionaalne testimine. Analüüsitud teave on väärtuslik veaanalüüsiga tegelevate inseneride jaoks, et saada täielik läbipaistvus toote vigade kohta, mis lisaks aitab teha andmepõhiseid otsuseid selle kohta, milliseid vigu tuleks põhjalikumalt analüüsida.

Seda kontseptsiooni rakendatakse 38,2 m² suurusel alal ja see on mõeldud kuni 2 inimese tööks. See koosneb mehaanilise, visuaalse ja elektrikontrolli tööjaamadest, kus on lisaks 2 riulit materjali ladustamiseks. Mehaanilised ja visuaalsed töökohad kombineeriti, kuna see kasutaks töökohta tõhusamalt. Elektrikontrolli tööjaam pidi vastama standardile EN ISO 13849-1, mis määras kindlaks, et selle tööjaama toimivus peab olema PLd tasemel. Selle tööjaama mehaaniline konstruktsioon keskendub ohutusaspektidele, mis takistavad töötajal puutuda füüsiliselt kokku pingestatud osadega, ning kaane avamis- ja sulgemismehhanismi kavandamisele. Kaant liigutatakse gaasiamortide abil, mis hoiavad kaant avatud ja suletud asendis. Elektri disain keskendub pinge rakendamisele ainult tööasendis. Seda tagatakse elektriliste ohutusseadmete kasutamisega, millel on eelnevalt arvatud PL-väärtused ja mis lubavad kasutajal rakendada pinget ainult siis, kui kaas on suletud ja lukustatud. See välistab elektrilöögi võimaluse, kui inimene ei järgi õigeid ohutusmeetmeid. Toimimistaseme arvutused näitasid, et see tööjaam ületab miinimumnõudeid, saavutades PLe, mis muudab elektrilise ülevaatus tööjaama ohutuks ja vastab standardile EN ISO 13849-1.

Hinnanguliselt maksab kogu kontseptsioon 15 388 eurot. Suurima osa sellest maksumusest moodustab elektrikontrolli tööjaam. On võimalik jätta mõned funktsioonid välja, mis ei mõjutaks oluliselt tõhusust ja vähendaks veidi kulusid, kuid üldiselt jäävad ligikaudsed kulud sellesse vahemikku.

8. REFERENCES

- [1] Treston, "Workbench planner," [Online]. Available: https://3d.treston.com/?duid=TrestonUK&distributor_workbench=TAG_TRESTON_WB. [Accessed 13 05 2023].
- [2] ABB, "Safety in control systems according to EN ISO 13849-1," [Online]. Available: [https://search.abb.com/library/Download.aspx?DocumentID=2TLC172003B02002&LanguageCode=en&DocumentPartId=&Action=Launch#:~:text=Choice%20of%20technology%20%E2%80%A2%20PL,pneumatic%20and%20hydraulic%20safety%20solutions.&text=SIL%20\(Safety%20Integrity%20Lev.](https://search.abb.com/library/Download.aspx?DocumentID=2TLC172003B02002&LanguageCode=en&DocumentPartId=&Action=Launch#:~:text=Choice%20of%20technology%20%E2%80%A2%20PL,pneumatic%20and%20hydraulic%20safety%20solutions.&text=SIL%20(Safety%20Integrity%20Lev.) [Accessed 18 05 2023].
- [3] Eaton, [Online]. Available: <https://www.eaton.com/gb/en-gb/markets/machine-building/service-and-support-machine-building-moem-service-eaton/blogs/difference-between-sil-and-pl.html>. [Accessed 18 05 2023].
- [4] Minitec, [Online]. Available: https://www.minitecframing.com/Assembly_Examples/Doors/DOORS_BI-FOLD/SP042914%20SINGLE%20BI-FOLD%2045X45/SP042914_SINGLE_BI-FOLD_DOOR.html. [Accessed 13 05 2023].
- [5] Minitec, [Online]. Available: https://www.minitecframing.com/application_pages/Enclosures_2016/Vertical_Bi-fold_Door/Vertical_Gas_Shock_Door_Closed.JPG. [Accessed 13 05 2023].
- [6] Minitec, [Online]. Available: https://www.minitecframing.com/application_pages/Enclosures_2016/Vertical_Bi-fold_Door/Vertical_Fold_Up_Door_Open.JPG. [Accessed 13 05 2023].
- [7] Minitec, [Online]. Available: https://www.minitecframing.com/application_pages/Enclosures_2016/ENCLOSURE%20WITH%20COUNTERWEIGHTED%20DOOR/Enclosure%20With%20Counterweighted%20Sliding%20Door%206.JPG. [Accessed 13 05 2023].
- [8] Les Jöfors AB, [Online]. Available: <https://catalog.lesjoforsab.com/product/9229-22-10-e-548-250-900n>. [Accessed 13 05 2023].
- [9] ABB, "Connection diagrams - Sentry safety relays," [Online]. Available: https://library.e.abb.com/public/6b1657f6489443e28adfca80d984b988/Sentry_connection_diagrams_2TLC010026T0001_revB3.pdf. [Accessed 12 05 2023].
- [10] Les Jörs AB, "https://www.lesjoforsab.com," [Online]. Available: <https://www.lesjoforsab.com/technology/gas-springs/>. [Accessed 14 04 2023].

APPENDICES

APPENDIX 1 TOOLS FOR MECHANICAL AND VISUAL WORKSTATION

No	Name	Quantity	Description
1.1	Screwdriver non insulated	1	13 piece wera set (slot, phili, pozi, torx) with holder
1.2	Screwdriver insulated	1	6 piece wera set (slot, pozi)
1.3	Hex keys set	1	Garant Hexagon screwdriver set, 8 pcs, with holder
1.4	Torx keys set	1	Garant Torx screwdriver set, 8 pcs, with holder
1.5	Needle nose pliers	1	200mm Knipex Snipe nose pliers insulated
1.6	Regular pliers	1	200mm Knipex pliers insulated
1.7	Medium cutting pliers	1	180 mm Knipex medium sidecutters insulated
1.8	Electronics cutting pliers	1	125 mm Knipex electronics side cutter insulated
1.9	Pliers wrench	1	250 mm Garant adjustable pliers
1.10	Hammer soft	1	D=22 mm Wera plastic insert hammer
1.11	Hammer hard	1	300g
1.13	6 mm Spanner/ratchet ring spanner	1	reversible 15deg offset
1.14	7 mm Spanner/ratchet ring spanner	1	reversible 15deg offset
1.15	8 mm Spanner/ratchet ring spanner	1	reversible 15deg offset
1.16	10 mm Spanner/ratchet ring spanner	1	reversible 15deg offset
1.17	12 mm Spanner/ratchet ring spanner	1	reversible 15deg offset
1.18	13 mm Spanner/ratchet ring spanner	1	reversible 15deg offset
1.19	17 mm Spanner/ratchet ring spanner	1	reversible 15deg offset
1.20	Small screwdrivers	1	6 pcs, ESD, with holder
1.21	Small drawer set	1	552x306x150 mm, drawer size: 91x154x64 (24pcs)
1.22	Flat file	1	250 mm

1.23	Knife	1	Martor SECUPRO MAXISAFE, ABB approved knife.
1.24	Replacement blades for knife	2	Set of spare blades
1.25	wire stripping tool	1	Weidmüller STIPAX, 0,08 - 10 mm ²
1.26	Crimping tool	1	Garant, 0,08-10 mm ²
1.27	Perforated wall	2	Perforated panel for wall mounting, 1554x500mm
1.28	Scissors	1	take from office
1.29	Dust shovel	1	
1.30	Broom	1	
1.31	Dustbin	1	
1.32	Cordless drill	1	Makita cordless drill (model: DDF487Z) + charger + 2 2Ah batteries
1.33	Goggles	2	
1.34	Dust mask	2	
1.35	Rag holder	1	with wheels
1.36	Caliper	1	150 mm digital caliper ORION
1.37	Würth wrench set	1	Same as in lab
1.38	Tape measure	1	5m tape measure
1.39	Cordless drill 1/4 bits	1	Würth kit 31 pcs, various screwdriver types
1.40	Würth drill kit	1	1-10 mm, 0,5mm increments, 19 pcs
1.42	Flashlight	1	10 - 380 lm, 3xAAA, 99g, Superbeam Q3
1.43	telescopic mirror	1	Diam 32 mm
1.44	Ruler	1	300 mm, metall
1.45	Telescopic magnet	1	500g, 670 mm
1.46	Magnetic bowl	1	240x145 mm
1.47	Digital camera microscope	2	DI LI 1001 D

APPENDIX 2 TOOLS AND EQUIPMENT FOR ELECTRICAL INSPECTION WORKSTATION

No	Electronics	Quantity	Description
3.1	PSU 24 V 2 channel	1	EL302RT Aim-tti instruments Bench Power Supply, Linear Regulated, Adjustable, 3 Output, 0 V, 30 V, 0 A, 2 A
3.2	Multimeter	1	Fluke 87-5 kit = Fluke + testleads + magnet + crocodile clamps + thermocouple Industrial Digital Multimeter Kit, 80 Series V, 20000 Count, True RMS, Auto, Manual Range, 4.5 Digit
3.6	Sharp multimeter probe tips	2	Needle-like
3.7	Multimeter magnet	0	Fluke magnet
3.8	Red banana test lead 1m	6	Tenma; Banana Test Lead, 4mm Stackable Banana Plug, Shrouded, 4mm Stackable Banana Plug, Shrouded 28A 1kV
3.9	Black banana test lead 1m	6	Tenma; Banana Test Lead, 4mm Stackable Banana Plug, Shrouded, 4mm Stackable Banana Plug, Shrouded 28A 1kV
3.10	Red banana test lead 0,5m	6	Tenma; Banana Test Lead, 4mm Stackable Banana Plug, Shrouded, 4mm Stackable Banana Plug, Shrouded 20A 1kV
3.11	Black banana test lead 0,5m	6	Tenma; Banana Test Lead, 4mm Stackable Banana Plug, Shrouded, 4mm Stackable Banana Plug, Shrouded 36A 1kV
3.12	Red banana test lead 2m	6	Tenma; Banana Test Lead, 4mm Stackable Banana Plug, Shrouded, 4mm Stackable Banana Plug, Shrouded 20A 1kV
3.13	Black banana test lead 2m	6	Tenma; Banana Test Lead, 4mm Stackable Banana Plug, Shrouded, 4mm Stackable Banana Plug, Shrouded 20A 1kV
3.14	Test probe - hook red	4	Pico; TA090 Test Probe Connector, Hook, Multifunction, Test & Measuring Instruments 1000 V CAT III 20 A
3.15	Test probe - hook black	4	Pico; TA090 Test Probe Connector, Hook, Multifunction, Test & Measuring Instruments 1000 V CAT III 20 A
3.16	Test probe - clamp red	2	HIRSCHMANN TEST AND MEASUREMENT KLEPS 2600; AC/DC 1000V; 4A; CAT III
3.17	Test probe - clamp black	2	HIRSCHMANN TEST AND MEASUREMENT KLEPS 2600; AC/DC 1000V; 4A; CAT III

3.18	Test probe - crocodile clip red	2	Stäubli; 1000 V, CAT III, 16 A Test Probe Connector, Red, Crocodile Clip, Ø 4 mm plugs with rigid insulating sleeve, GRIP-CI not produced anymore
3.19	Test probe - crocodile clip red 2	4	Stäubli; Crocodile Clip, 1000V, CAT IV, 20 mm, 16 A, Red
3.20	Test probe - crocodile clip black 2	4	Stäubli; Crocodile Clip, 1000V, CAT IV, 20 mm, 16 A, Black
3.21	Test lead rack	2	For wall mounting
3.22	Lamp with magnifying glass	1	DURATOOL, DT000092

APPENDIX 3 MECHANICAL DRAWINGS FOR ELECTRICAL INSPECTION WORKSTATION

APPENDIX 4 ELECTRICAL SCHEMATICS FOR ELECTRICAL INSPECTION WORKSTATION

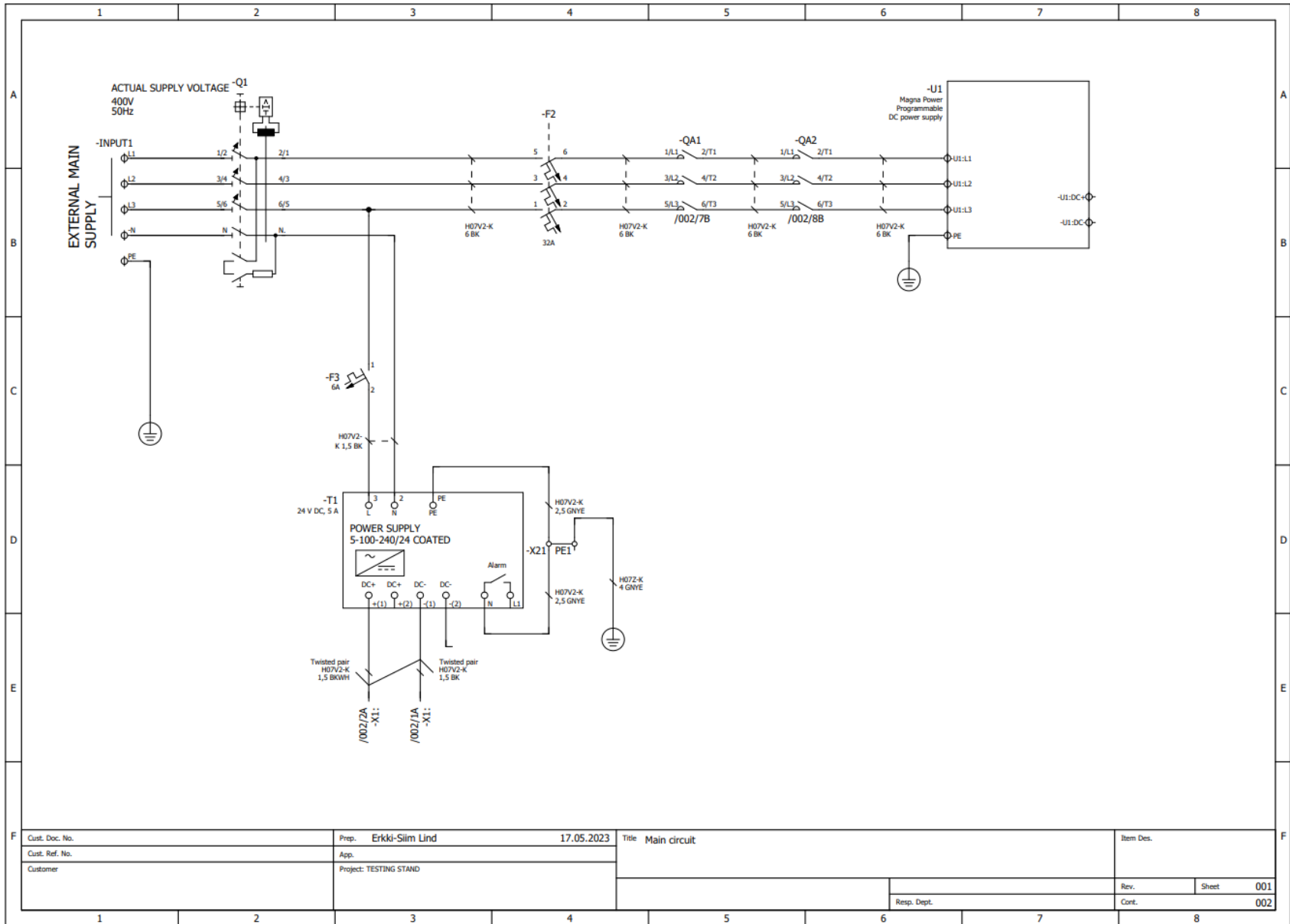

Cust. Doc. No.	Prep. Erkki-Slim Lind	17.05.2023	Title Main circuit	Item Des.
Cust. Ref. No.	App.			
Customer	Project: TESTING STAND			
			Resp. Dept.	Rev. Sheet 001
				Cont. 002

